



Part#: 122303

Product: Dual Shock Kit

Application: Dodge

READ AND UNDERSTAND ALL INSTRUCTIONS AND WARNINGS PRIOR TO INSTALLATION OF SYSTEM AND OPERATION OF VEHICLE.

SAFETY WARNING BDS Suspension Co. recommends this system be installed by a professional technician. In addition to these instructions, professional knowledge of disassembly/ reassembly procedures and post installation checks must be known.

PRODUCT SAFETY WARNING Certain BDS Suspension products are intended to improve off-road performance. Modifying your vehicle for off-road use may result in the vehicle handling differently than a factory equipped vehicle. Extreme care must be used to prevent loss of control or vehicle rollover. Failure to drive your modified vehicle safely may result in serious injury or death. BDS Suspension Co. does not recommend the combined use of suspension lifts, body lifts, or other lifting devices.

You should never operate your modified vehicle under the influence of alcohol or drugs. Always drive your modified vehicle at reduced speeds to ensure your ability to control your vehicle under all driving conditions. Always wear your seat belt.

PRE-INSTALLATION NOTES

1. Special literature required: OE Service Manual for model/year of vehicle. Refer to manual for proper disassembly/ reassembly procedures of OE and related components.
2. Adhere to recommendations when replacement fasteners, retainers and keepers are called out in the OE manual.
3. Larger rim and tire combinations may increase leverage on suspension, steering, and related components. When selecting combinations larger than OE, consider the additional stress you could be inducing on the OE and related components.
4. Post suspension system vehicles may experience drive line vibrations. Angles may require tuning, slider on shaft may require replacement, shafts may need to be lengthened or trued, and U-joints may need to be replaced.
5. Secure and properly block vehicle prior to installation of BDS Suspension components. Always wear safety glasses when using power tools.
6. If installation is to be performed without a hoist, BDS Suspension Co. recommends rear alterations first.
7. Due to payload options and initial ride height variances, the amount of lift is a base figure. Final ride height dimensions may vary in accordance to original vehicle attitude. Always measure the attitude prior to beginning installation.

POST-INSTALLATION WARNINGS

1. Check all fasteners for proper torque. Check to ensure for adequate clearance between all rotating, mobile, fixed, and heated members. Verify clearance between exhaust and brake lines, fuel lines, fuel tank, floor boards and wiring harness. Check steering gear for clearance. Test and inspect brake system.
2. Perform steering sweep to ensure front brake hoses have adequate slack and do not contact any rotating, mobile or heated members. Inspect rear brake hoses at full extension for adequate slack. Failure to perform hose check/ replacement may result in component failure. Longer replacement hoses, if needed can be purchased from a local parts supplier.
3. Perform head light check and adjustment.
4. Re-torque all fasteners after 500 miles. Always inspect fasteners and components during routine servicing.

PARTS LIST

Part #	Qty	Description
	2	Upper Shock Mounts (LH/RH)
	2	Lower Shock Mounts (LH/RH)
	2	Shock Tower 3 Bolt Ring
	1	Loctite
	3	3/8" Nuts
	1	Hardware Pack
	2	M12 x 100 Bolt
	2	M12 Lock Nuts
	2	M12 Washers
	4	1/2"-20 x 3.25" Bolts
	2	1/2"-20 x 1.75" Bolts
	28	1/2" Flatwashers
	6	1/2" Lock Nuts

INSTALLATION INSTRUCTIONS

1. Safely raise the vehicle and support with jack stands for safety.
2. Remove the tires and wheels.
3. Place support floor jack under the front axle.
4. Disconnect the shock absorbers by first removing the nut, retainer and grommet from the shock absorber studs in the engine compartment.

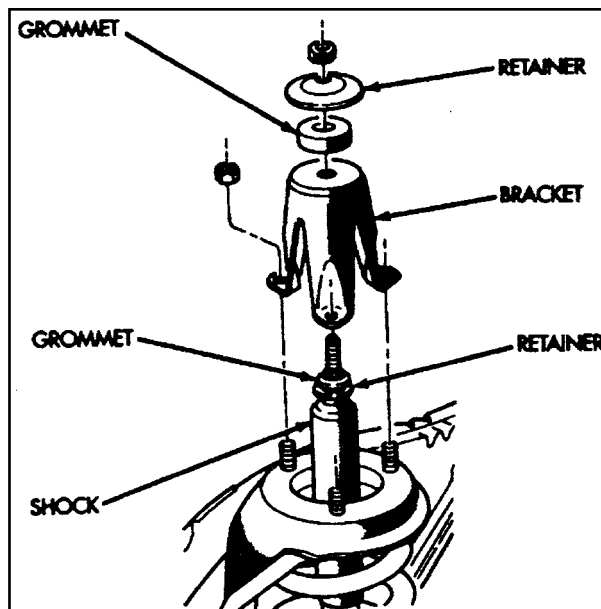

5. Remove the three studs retaining the upper shock tower.
6. Lower the front axle to allow the coil springs to be removed. From the upper spring pocket remove the rubber isolation pad and the OE shock stud ring.
7. Replace the OE shock stud ring with the supplied ring. Replace OE rubber isolator and coil spring.
8. Place the upper shock mount on top of the spring pocket over the three studs. Align the mounts so that the shock tabs point toward the rear of the vehicle and the three holes line up with the holes in the spring pocket. These brackets are left and right hand parts. When the brackets are in place, the bent shock tab should be closest to the tin.
9. Place the OE upper shock tower bracket on top of the supplied auxiliary shock mount. Install supplied nuts with loctite on to the studs. Torque fasteners to 55 ft-lbs.
10. Place the upper grommet and retainer on the shock stud and install the upper shock nut. Torque to 30 ft-lbs. Repeat these steps for the other side of the vehicle.

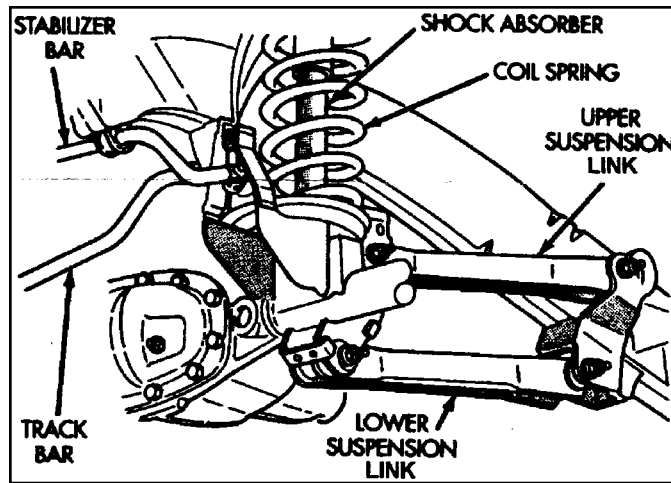

11. Remove the nut and bolt from the axle end of where the upper link was originally attached. Replace the stud with the supplied M12 x 100 bolt and washer (on bolt head side only). Do not install nut at this time. Repeat this for the opposite side of the vehicle.
12. Place the round hole of the lower shock mount bracket over the M12 stud. Rotate the bracket so that the slotted hole lines up with the unused factory hole that is about 4" below the upper link bolt. The lower shock mount brackets are a left and right. With the bracket on the stud, the slotted hole should line up with the existing OE hole where the shock mounting tabs are perpendicular to the ground.
13. Install the 1/2" x 1 3/4" bolt through this assembly. **Note:** the factory bolt hole may need to be enlarged to accept the 1/2" bolt. Install the M12 and 1/2" nuts and torque to specification.

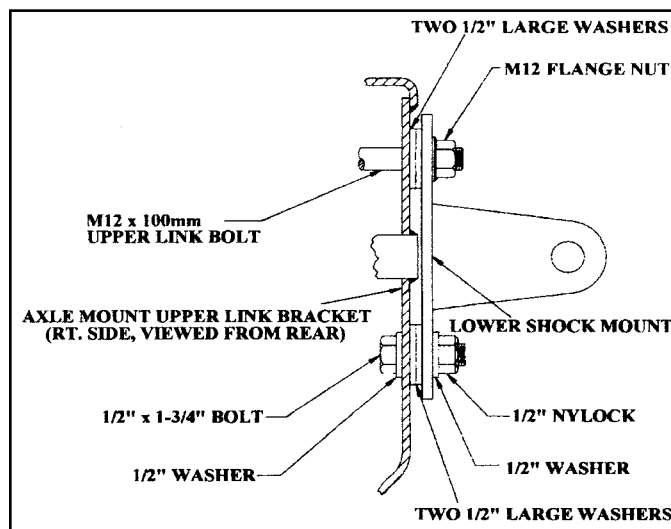

Repeat for opposite side of vehicle.

14. Install appropriate BDS auxiliary shocks. The 1/2" x 3.25" bolts, nuts, and washers are supplied for shock installation. Torque nuts to 100 ft-lbs.
15. Reinstall wheels and lower the vehicle to the ground and bounce the vehicle in order to settle the coils in place.
16. Torque the upper link axle nut to 89 ft-lbs.
17. Double check all fasteners and clearance for a full turning radius.
18. Adjust headlights to proper setting and install the warning card.
19. This vehicle will need to be aligned after the kit is installed.