

# Installation instructions

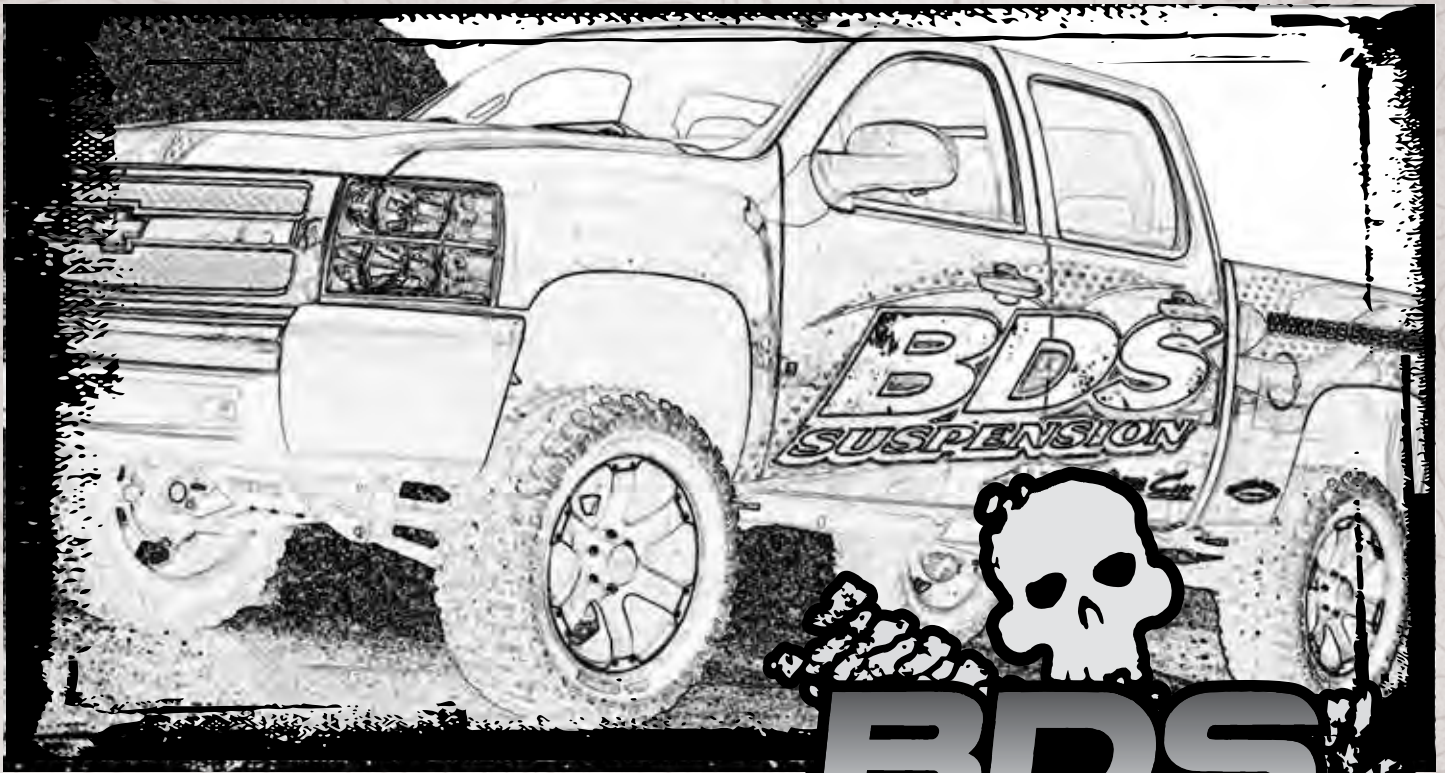

Part#: 121406, 121409, 123409



**Chevy 1500 Recoil  
Traction Bar System**



# Read And Understand All Instructions And Warnings Prior To Installation Of System And Operation Of Vehicle.

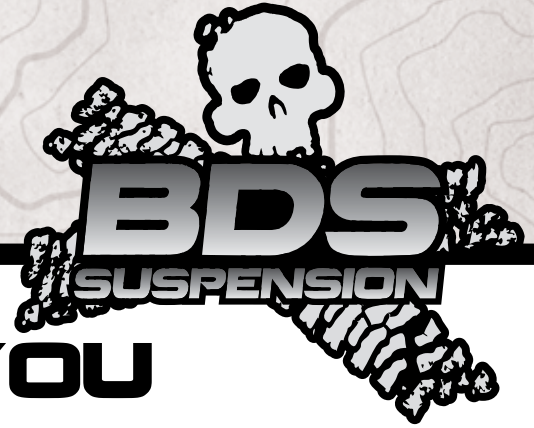

## THANK YOU

Your truck is about to be fitted with the best suspension system on the market today. That means you will be driving the baddest looking truck in the neighborhood, and you'll have the warranty to ensure that it stays that way for years to come. Thank you for choosing BDS Suspension!

### BEFORE YOU START

BDS Suspension Co. recommends this system be installed by a professional technician. In addition to these instructions, professional knowledge of disassembly/ reassembly procedures and post installation checks must be known.

### FOR YOUR SAFETY

Certain BDS Suspension products are intended to improve off-road performance. Modifying your vehicle for off-road use may result in the vehicle handling differently than a factory equipped vehicle. Extreme care must be used to prevent loss of control or vehicle rollover. Failure to drive your modified vehicle safely may result in serious injury or death. BDS Suspension Co. does not recommend the combined use of suspension lifts, body lifts, or other lifting devices. You should never operate your modified vehicle under the influence of alcohol or drugs. Always drive your modified vehicle at reduced speeds to ensure your ability to control your vehicle under all driving conditions. Always wear your seat belt.

### BEFORE INSTALLATION

Special literature required: OE Service Manual for model/year of vehicle. Refer to manual for proper disassembly/reassembly procedures of OE and related components.

Adhere to recommendations when replacement fasteners, retainers and keepers are called out in the OE manual.

Larger rim and tire combinations may increase leverage on suspension, steering, and related components. When selecting combinations larger than OE, consider the additional stress you could be inducing on the OE and related components.

Post suspension system vehicles may experience drive line vibrations. Angles may require tuning, slider on shaft may require replacement, shafts may need to be lengthened or trued, and U-joints may need to be replaced.

Secure and properly block vehicle prior to installation of BDS Suspension components. Always wear safety glasses when using power tools.

If installation is to be performed without a hoist, BDS Suspension Co. recommends rear alterations first.

Due to payload options and initial ride height variances, the amount of lift is a base figure. Final ride height dimensions may vary in accordance to original vehicle attitude. Always measure the attitude prior to beginning installation.

### BEFORE YOU DRIVE

Check all fasteners for proper torque. Check to ensure for adequate clearance between all rotating, mobile, fixed, and heated members. Verify clearance between exhaust and brake lines, fuel lines, fuel tank, floor boards and wiring harness. Check steering gear for clearance. Test and inspect brake system.

Perform steering sweep to ensure front brake hoses have adequate slack and do not contact any rotating, mobile or heated members. Inspect rear brake hoses at full extension for adequate slack. Failure to perform hose check/ replacement may result in component failure. Longer replacement hoses, if needed can be purchased from a local parts supplier.

Perform head light check and adjustment.

Re-torque all fasteners after 500 miles. Always inspect fasteners and components during routine servicing.

# CONTENTS OF YOUR KIT

## Box Kit 121406, 121409

Part #	Qty	Description
02969	2	GM 1500 Axle Mount
02971	2	GM 1500 Frame Mount
02910	2	Jam Nut Wrench
964	1	Bolt Pack (Traction Bar Hardware)
	4	9/16"-12 x 4" Bolt Grade 8
	4	9/16"-12 Prevailing Torque Nut
	8	9/16" SAE Washer
958	1	Bolt Pack Frame Mount (Box Kit 121406)
	8	1/2"-13 x 1-1/2" Bolt Grade 8
	8	1/2"-13 Prevailing Torque Nut
	16	1/2" SAE Washer
342701	1	Loctite (Box Kit: 121409)
95105A169	9	Rivet Nuts (Box Kit 121409)
973	1	Bolt Pack Frame Mount (Box Kit 121409)
	8	1/2"-13 x 1-1/2" Bolt Grade 8
	8	1/2" SAE Washer
799	1	Bolt Pack Rivet Nut Install (Box Kit: 121409)
	1	1/2"-13 x 2" bolt grade 8 yellow zinc
	1	1/2" SAE flat washer yellow zinc
	1	1/2" star washer external tooth clear zinc
	1	9/16"-18 hex high nut yellow zinc
W96S	8	9/16" SAE Washer

## Box Kit 123409

Part #	Qty	Description
A255	2	Traction Bar Assembly
02865	1	Traction Bar
02866	1	Spacer Washer
02867	1	Bushing
02868	1	Guide Bolt
02869	1	Traction Bar Slider End
033001	1	Heavy Rate Spring
033002	1	Lite Rate Spring
9452K63	2	O-Ring
91985A231	1	Internal Retaining Ring
3537BK	2	Bushings
61	1	Sleeve
516	2	Grease Fitting
A171	1	Forged Flex Joint End

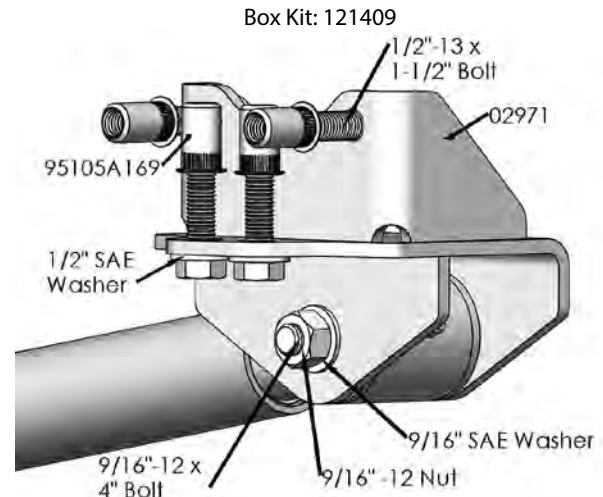
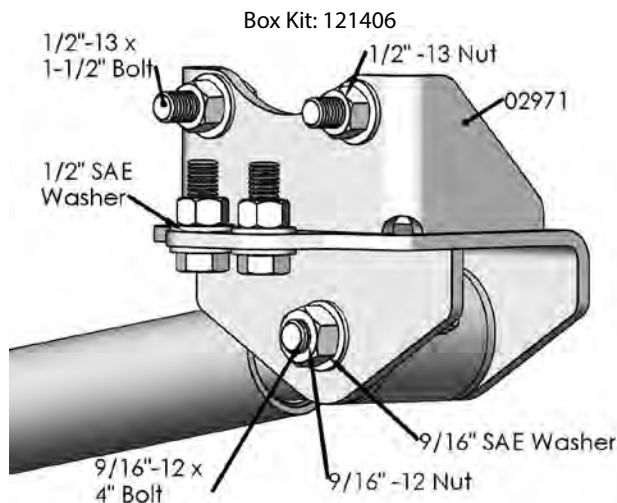
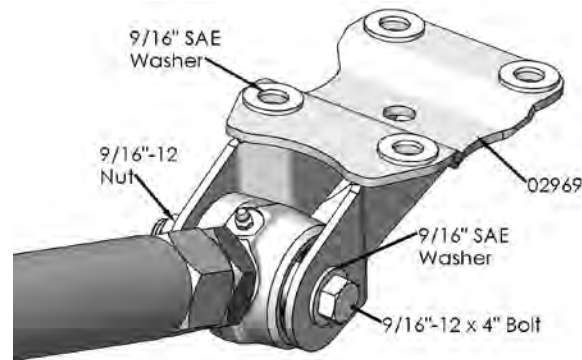



# INSTALLATION INSTRUCTIONS

## AXLE BRACKET INSTALLATION INSTRUCTIONS

1. Park the vehicle on a clean, flat surface and block the rear wheels for safety.

**! Caution** *This installation must be done with the weight of the vehicle on the rear axle. Do not raise the vehicle and allow the rear axle to hang.*

2. Measure the length of thread on the U-bolt showing past the end of nut. A minimum of 0.25" of thread must be showing past the end of the nut in order to install the axle bracket. If not enough thread is showing, new / longer u-bolts will be required.
3. Remove the driver's side u-bolt nuts and washers. If replacing u-bolts, remove old and install new now.
4. With the OE U-bolt plate in place, install a 9/16" SAE washer on each end of the u-bolts followed by the new traction bar axle mount bracket (02969). Make sure the mounting tabs on the bracket are to the front of the vehicle. Fasten the bracket with the U-bolt (new or used) nuts and washers (Fig 1). Torque U-bolts to 100-120 ft-lbs.

**FIGURE 1**

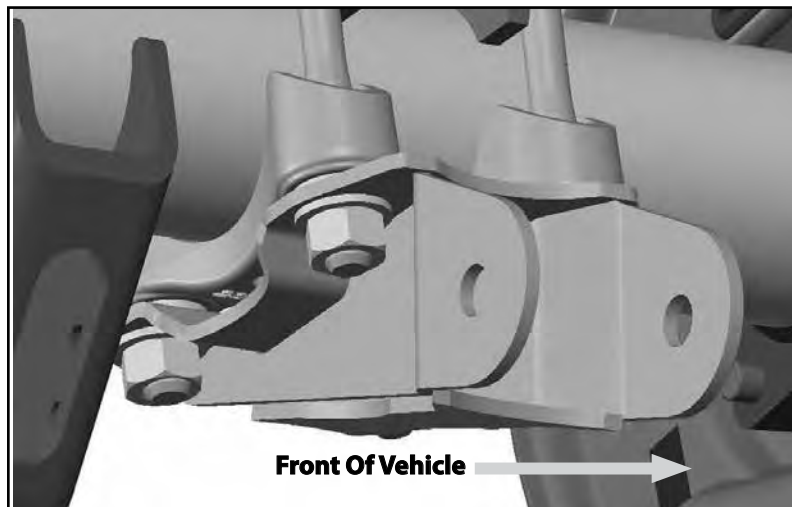

6. Repeat bracket installation on the passenger's side.

## TRACTION BAR INSTALLATION

7. Check that the jam nut on the Forged Flex End (A171) is threaded in as far as it can go on the shaft of the Forged Flex End. Make sure the Forged Flex End is completely threaded into the Traction Bar (02865) up to the jam nut as shown in Figure 2.

**FIGURE 2**

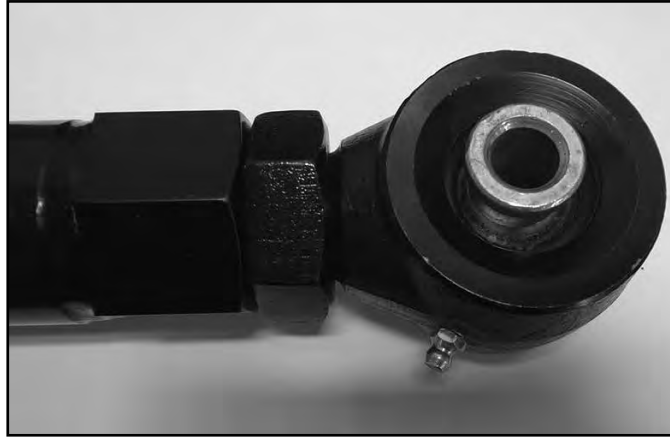

8. Attach the Traction Bar to the axle bracket with a 9/16" x 4" bolt, 9/16" nut and 9/16" SAE washers from Bolt Pack 964. Install the traction bar so that the Forged Flex End (A171) is mounted to the axle bracket. Leave mounting hardware loose at this time

**FIGURE 3**

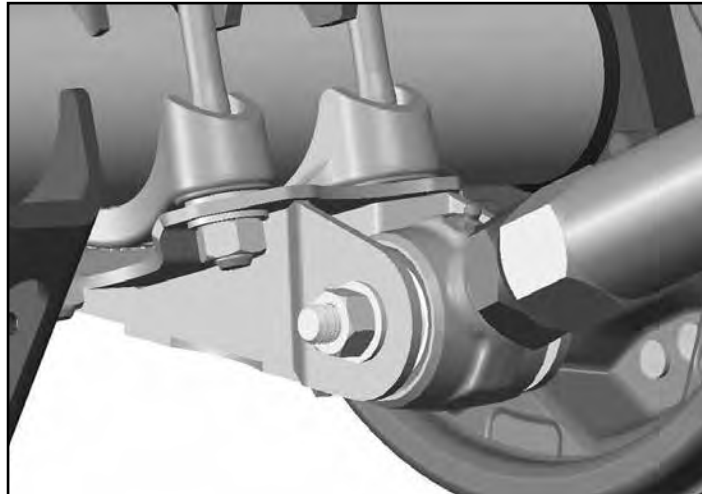

9. Measure the length of the bar from the center of the bolt at the axle to the center of the sleeve at the traction bar end (02869). The length should be approximately 59-3/4". If not, press firmly on the traction bar end to seat the springs.

## FRAME BRACKET INSTALLATION

10. Starting on the driver's side, loosely attach the provided frame bracket (02971) with a 9/16" x 4" bolt, 9/16" nut and 9/16" SAE washer from Bolt Pack 964 to the Traction Bar End (02869).
11. Place the bracket up to the frame so that the "L" in the bracket mounts to the frame. Hold the bracket flush against the frame and using the four holes in the bracket as a template, mark the location to be drilled on the frame. *Note: 88-98 Models may require a rivet to be ground off and punched out in order to attach the frame bracket. This hole can be used to mount the frame bracket.*

**FIGURE 4**





**Tip** When marking the location to drill the holes, make sure Forged Flex End is threaded all the way in, the traction bar slider end is seated firmly on the springs, and the length of the Recoil Traction Bar is approximately 59-3/4" +/-0.25" eye to eye.

12. 88-06 Models (Box Kit: 121406): Drill 1/2" holes in the frame at the four marks.
13. 88-06 Models (Box Kit: 121406): Place the bracket up to the frame and align the bracket holes with the previously drilled holes. Attach the bracket with the provided 1/2" bolt, SAE Washers, and prevailing torque nut (Bolt Pack 958). Torque the 1/2" bolts to 60 ft-lbs.
14. 07-16 Models (Box Kit 121409): Drill 11/16" holes at each of the four marks on the frame. *Note: Only drill through the one side of the boxed frame rail. A step drill is highly recommended.*
15. 07-16 Models (Box Kit 121409): Insert the rivet nut into the hole with 1/2" x 1-1/2" bolt with 9/16" high nut and serrated edge washer (Bolt Pack 799). Place a wrench on the high nut and tighten the 1/2" bolt until the rivet nut seats. Be sure to hold the rivet nut flange tight to the frame surface while setting the nut. Repeat for each hole. There is one extra rivet nut included with the kit, if one is installed incorrectly. See detailed rivet nut installation instructions at the end of this instruction sheet.
16. 07-16 Models (Box Kit 121409): Place the bracket up to the frame and align the bracket holes with the rivet nuts. Apply Loctite and attach the bracket with the provided 1/2" bolt and SAE Washer (Bolt Pack 973). Torque the 1/2" bolts to 60 ft-lbs.
17. Reattach the traction bar to the frame brackets using the 9/16" x 4" bolt, nut and 9/16" SAE washer. Torque to 90 ft-lbs at the frame and axle brackets.
18. Repeat the frame bracket and traction bar installation on the passenger side.
19. Grease all bushings and the Recoil Traction Bar before use. Do not over grease the Recoil Traction Bar, it is recommended to grease the Recoil Traction Bar one pump of grease every 10,000 miles.
20. Check all hardware for proper torque.
21. Check hardware after 500 miles.

## TRACTION BAR ADJUSTMENT

22. Loosen the jam nut at the axle end with the two provided wrenches. Utilize a 1/2" ratchet or breaker bar in the wrench if needed.

**FIGURE 5**



23. Use the levels on the wrench to gauge how much force is inputted into the Recoil Traction Bar. The wrench is designed to be used at the traction bar slider end as shown in Figure 6. Make sure the wrench is pressed firmly against the bushing / tube for an accurate measurement.

**FIGURE 6**

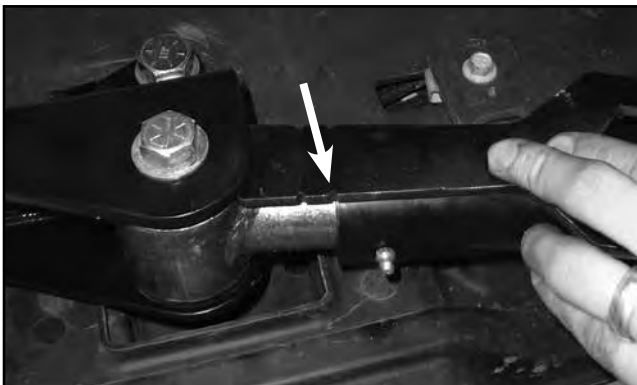

**FIGURE 7**

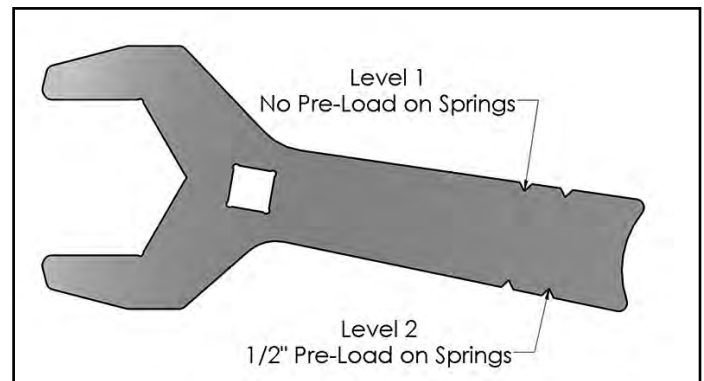

24. Utilizing the Levels on the wrench, spin the Recoil Traction Bar either clockwise to add more force into the dual coil springs setup to reduce



axle wrap, or loosen the Recoil Traction Bar by spinning it counter clockwise in order to reduce the input the Recoil Traction Bar has on the suspension system. *Note: Depending upon lift height, the Recoil Traction Bar may need to unthreaded from the Forged Flex End until the First Level is reached on the wrench. At this point the dual coil spring setup are in contact and there is no preload in the springs.*

**FIGURE 8**

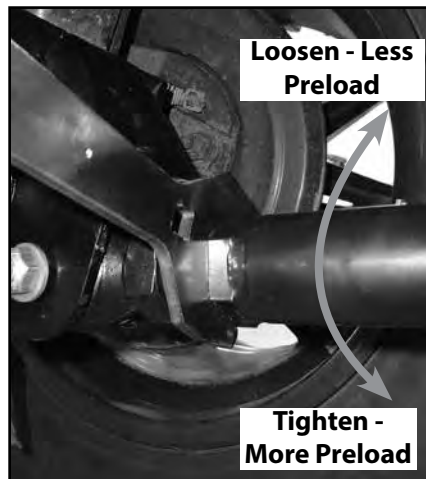

25. It is recommended when pulling or hauling heavy weights that Recoil Traction Bar be set at a minimum of the Second Level on the Jam Nut Wrench to help reduce axle wrap. The Second Level is 25% of the maximum force the springs output. The maximum amount of force that can be preloaded in the spring is 12 full rotations of the Recoil Traction Bar when starting at the First Level. This equals 1" of total preload in the dual coil spring setup in the Recoil Traction Bar. At this point, the dual coil spring setup creates a solid link between the frame and axle when in compression. DO NOT tighten the Recoil Traction Bar past this amount.

**FIGURE 9**



26. After the desired force is set, lock off the jam nut with the two provided Jam Nut Wrenches and repeat this process on the other Recoil Traction Bar. *Note: Never unthread the forged flex end past 1-1/2" of adjustment. This can cause thread damage and weaken the joint. See Figure 10.*

**FIGURE 10**



27. The dual coil spring setup is utilized to always create contact between both ends of the Recoil Traction Bar. Having dual coil spring setup allows the Recoil Traction Bar system to not affect suspension performance at a lower force as seen at the First Level, allowing greater

articulation and less affect on the suspension system. As the Recoil Traction Bar is adjusted and the dual coil spring setup is compressed, a higher force is exerted on the axle in order to reduce axle wrap. Each Level below corresponds to the levels on the wrench, representing different amounts of force in the Recoil Traction Bar system. *Note: It is recommended to never fully compress the spring past the 1" of compression. This can be measured 1" from the First Level on the Jam Nut Wrench.*

**FIGURE 11**

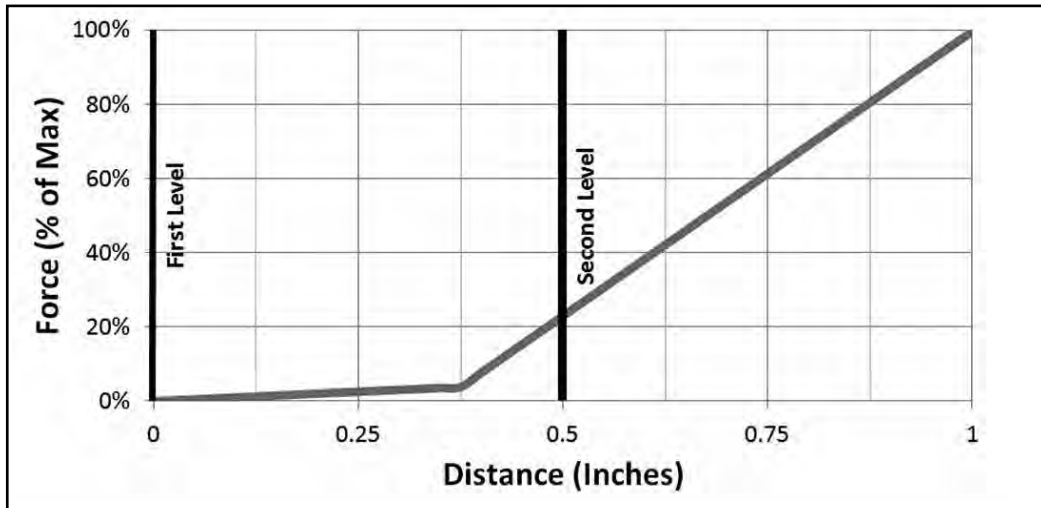

## RIVET NUT INSTALLATION INSTRUCTIONS

### RIVET NUT SIZING

1. Verify the correct size rivet nut for the application based on the thickness of material where the rivet nut is to be installed using the following chart.

Part Number	Thread Size	Body Length (in)	Material Thickness (in)		Drill Size (in)
			Min.	Max.	
95105A159	3/8-16	.690	.027	.150	17/32
95105A168	3/8-16	.805	.150	.312	17/32
95105A169	1/2-13	1.150	.063	.200	11/16
95105A170	1/2-13	1.300	.200	.350	11/16

## HOLE PREPARATION

2. Drill hole to appropriate size for rivet nut installation. 1/2" Rivnuts require an 11/16" hole and 3/8" Rivnuts require a 17/32" drill. It is critical that this hole is drilled to the correct size. Remove any burrs that could keep the rivet nut from seating flat against either side of the hole surface.



**Tip** *If the correct drill size is not available, it is possible to drill the hole to an available smaller size and slowly grind it out to until the rivet nut fits tight.*

## RIVET NUT INSTALLATION TOOL ASSEMBLY

3. For a 3/8" rivet nut, place the provided 3/8" SAE flat washer on the 3/8" x 1-1/2" bolt, followed by 7/16" hex nut and then a 3/8" serrated washer. (Fig 1) Thread this tool assembly into the rivet nut.
4. For a 1/2" rivet nut, place the provided 1/2" SAE washer on a 1/2" x 2" bolt followed by a 9/16" high nut and 1/2" serrated edge lock washer.



Thread this tool assembly into the rivet nut as shown. (Fig. 1)

**FIGURE 1 - 1/2" RIVET NUT SHOWN**

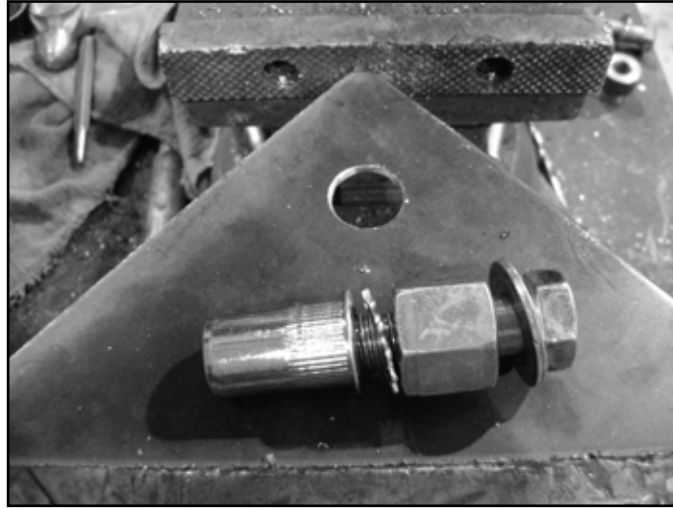

## RIVET NUT INSTALLATION

5. Place the installation tool with the rivet nut threaded on the end into the appropriately sized hole.
6. For a 3/8" rivet nut, hold the nut closest to the rivet nut still with a 5/8" wrench and tighten the 3/8" bolt with a 9/16" wrench to set the rivet nut. Be sure to hold the rivet nut flush to the surface and square to the hole as it is tightened. (Fig. 2)



**Tip** If available, an impact gun is recommended for tightening the bolt to ensure the rivet nut remains square to the hole and to ease holding the nut from spinning.

7. For a 1/2" rivet nut, hold the nut closest to the rivet nut still with a 7/8" wrench and tighten the 1/2" bolt with a 3/4" wrench to set the rivet nut. Be sure to hold the rivet nut flush to the surface and square to the hole as it is tightened. (Fig. 2)

**FIGURE 2 - 1/2" RIVET NUT SHOWN**



## TORQUE SPECIFICATIONS

- 3/8" rivet nuts will approach 40 ft. lbs for maximum grip strength. Do not exceed 45 ft-lbs when setting the rivet nut.
- 1/2" rivet nuts will approach 90 ft lbs for maximum grip strength. Do not exceed 100 ft-lbs when setting the rivet nut.



**Tip** If using the recommended impact gun, use caution to not exceed the recommended torque specifications.

## RIVET NUT TOOL REMOVAL

8. Once the center bolt is tightened, remain holding the nut from spinning with the wrench and loosen the center bolt to remove the installation tool.

**! Caution** *It is very important to hold the nut as the bolt is loosened because the grip of the star washer will try to spin the rivet nut and ruin the installation.*

9. Verify proper installation by checking for consistent rivet nut deformation to see the threads are square and centered to the rivet nut. (Fig. 3)

**FIGURE 3**

