

Flowmax Heater Installation Manual





Installation Instructions

P/N #	1050346
P/N #	1050347
P/N #	1050348





PLEASE READ ALL INSTRUCTIONS BEFORE INSTALLATION

KIT CONTENTS:

Please check to make sure that you have all the parts listed in this kit **before** you start the disassembly of your truck.

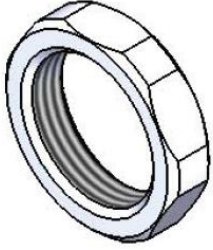
1050346 – HEATER KIT FOR THE BD FLOWMAX SYSTEM			
1500343	1500342	1302174	1500375
			
Heater	Nut; 3/4"-16	Thread Lock (BLUE)	Adapter
Qty: 1	Qty: 1	Qty: 1	Qty: 1
1500420			
			
Harness; Fuel Heater Flowmax			
Qty: 1			

1050347 – HEATER KIT FOR THE AIRDOG SYSTEM

1500343	1500342	1302174
		
Heater Qty: 1	Nut; 3/4"-16 Qty: 1	Thread Lock (BLUE) Qty: 1
1500420	1500376	1500407
		
Harness; Fuel Heater Flowmax Qty: 1	Adapter (Airdog 1) Qty: 1	Adapter (Airdog 2 & Airdog 2-4G) Qty: 1

1050348 – HEATER KIT FOR THE FASS SYSTEM

1500343	1302174	1500377
		

Heater	Thread Lock (BLUE)	Adapter
Qty: 1	Qty: 1	Qty: 1

1500420

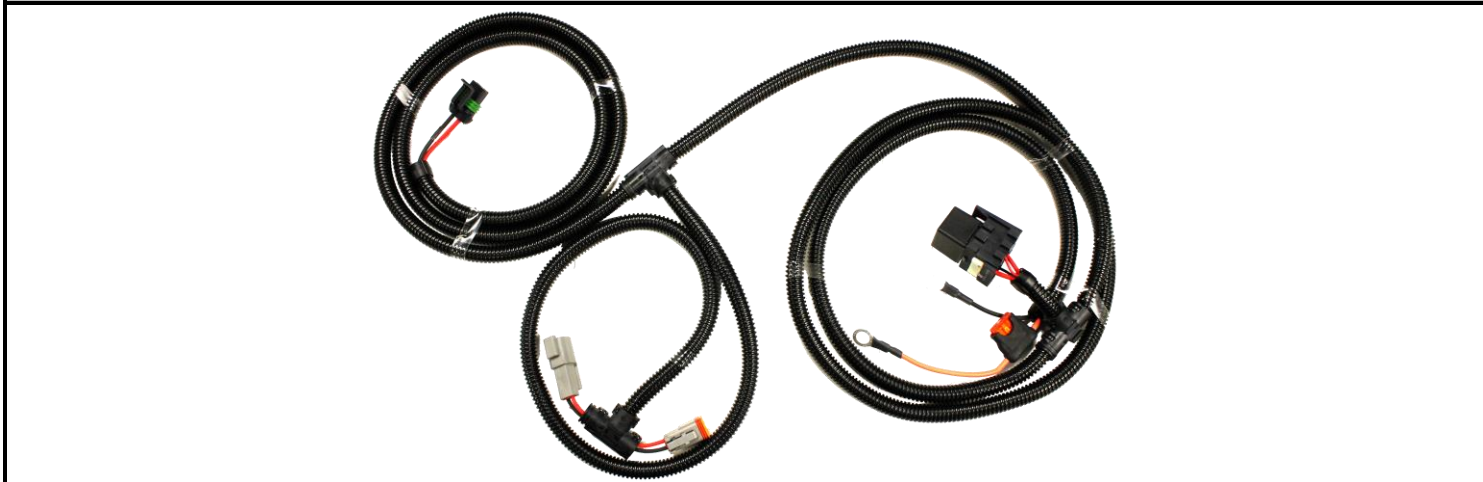

Harness; Fuel Heater Flowmax
Qty: 1

Optional Accessories:

1050350 -	WIF Sensor 2000-07 Dodge 5.9L
1050351 -	WIF Sensor 2007-12 Dodge 6.7L
1050355 -	WIF Sensor Universal
1050356 -	WIF Sensor Ford 2003-10

Introduction

The BD FlowMax Fuel Heater is an add on accessory for the BD FlowMax fuel lift pump system. It installs in conjunction with the BD 1050340-WSP water separator filter assembly. The supplied wiring harness automatically triggers the heater on when the FlowMax fuel pump is running.

Cold diesel fuel is susceptible to waxing or gelling. This solidification causes the fuel filter media to become partially clogged leading to fuel delivery issues. Fuel heaters help keep diesel fuel warm to prevent this problem and ensure a continuous fuel supply regardless of ambient temperature.

The BD Fuel Heater installs between the incoming fuel supply and the water separator filter, heating the cold fuel as it enters the filter. The BD Fuel Heater is a high power heater, far outperforming the competition. As the temperature drops the heater output increases to help maintain fuel temperatures. As the fuel temperature rises, the heater reduces its output to reduce wasted heat generation.

Installation:



FILTER REPLACEMENT AT THE TIME OF THE HEATER INSTALL IS ALWAYS RECOMMENDED.

1) Remove water separator filter and adapter from head if installed.

2) Install fuel heater threaded adapter (#1500375) into the Flowmax water separator head.

Use supplied thread lock to secure fitment.

Tighten with 1" wrench. *Do not over tighten.*

5 ft/lbs is sufficient.

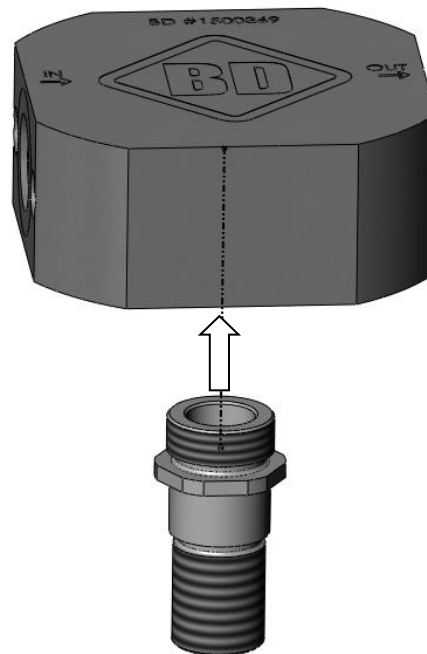

3) Heater connection on a BD Flowmax System

- a) Lubricate sealing ring surface with engine oil. Place sealing ring into heater receiving groove and slide the heating unit (#1500343) up against the filter head.

NOTE: It is suggested to replace the sealing ring when replacing the water separator.

Cummins P/N:383418500

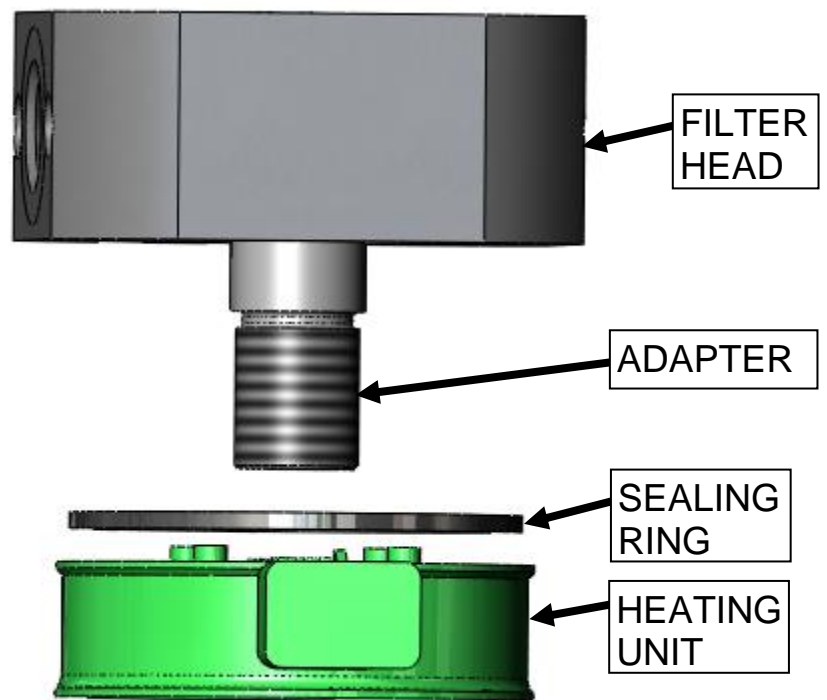

- b) Place a dab of blue thread lock onto the adapter then, thread the supplied panel nut (#1500342) onto the threaded stud, thereby securing the heater in place.

Ensure to orientate the wiring connector in the desired direction that is away from water spray or flying debris.

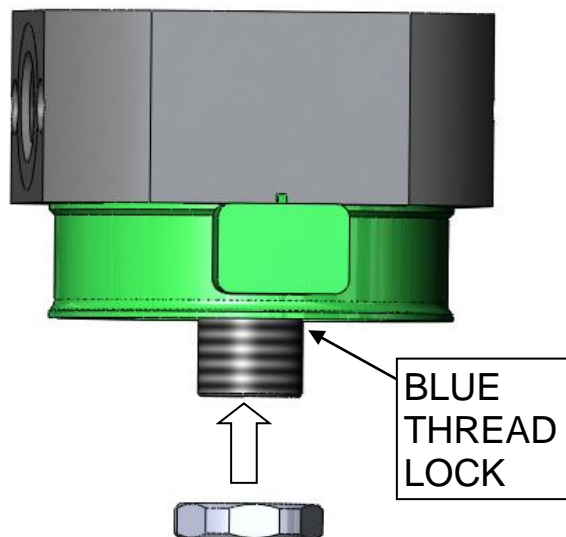

IMPORTANT: Clean excess thread locker from the exposed threads before installing filter otherwise the filter may be difficult to remove at the next service interval.

3. Heater connection on an Air Dog System

- a) Lubricate sealing ring surface with engine oil. Place sealing ring into heater receiving groove and slide the heating unit (#1500343) up against the filter head.

Pump	Adapter
Air Dog 1	1500376
Air Dog 2	1500407
Air Dog 2-4G	1500407

NOTE: It is suggested to replace the sealing ring when replacing the water separator.
Cummins P/N:383418500

- b) Place a dab of blue thread lock onto the adapter then, thread the supplied panel nut (#1500342) onto the threaded stud, thereby securing the heater in place.

Ensure to orientate the wiring connector in the desired direction that is away from water spray or flying debris

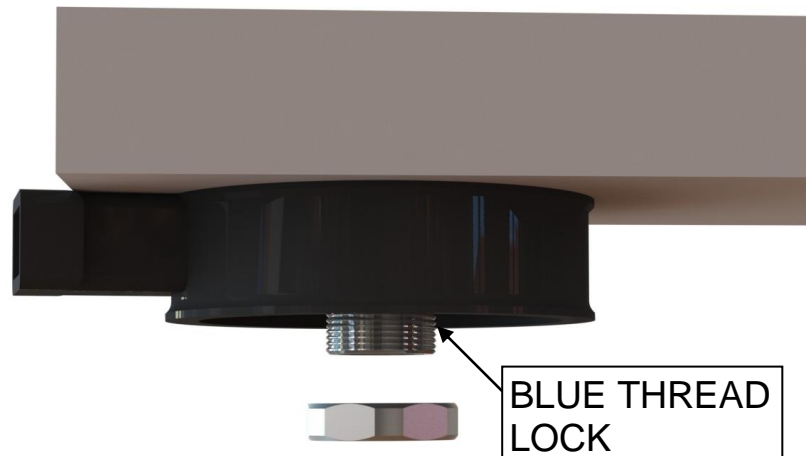
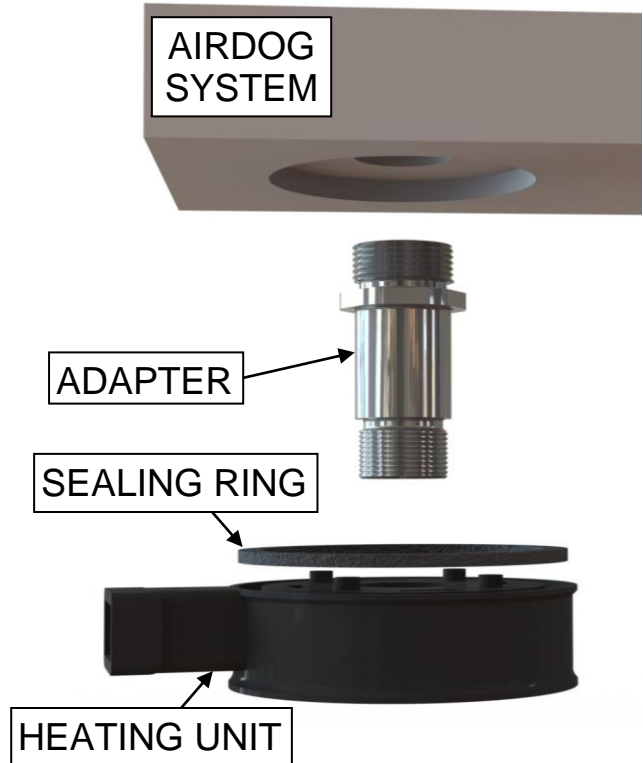

IMPORTANT: Clean excess thread locker from the exposed threads before installing filter otherwise the filter may be difficult to remove at the next service interval.

3. Heater connection on a FASS System

- a) Apply Blue LOCKTITE to the threads (refer to picture)
- b) Install seal into the PTC Fuel Heater

NOTE: It is suggested to replace the sealing ring when replacing the water separator.

Cummins P/N:383418500

- c) Hold PTC Fuel Heater up against the filter head and secure with the provided adapter (1500377)

Ensure to orientate the wiring connector in the desired direction that is away from water spray or flying debris

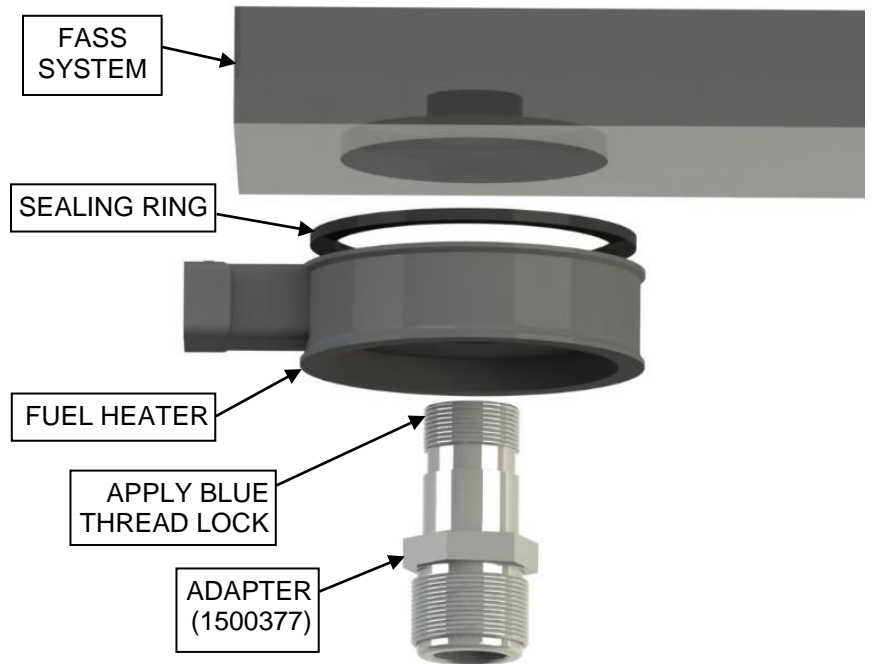

IMPORTANT: Clean excess thread locker from the exposed threads before installing filter otherwise the filter may be difficult to remove at the next service interval.

- 4.** Lubricate the sealing ring of the water separator filter before installation.

Thread filter onto threaded stud. Do not overtighten.

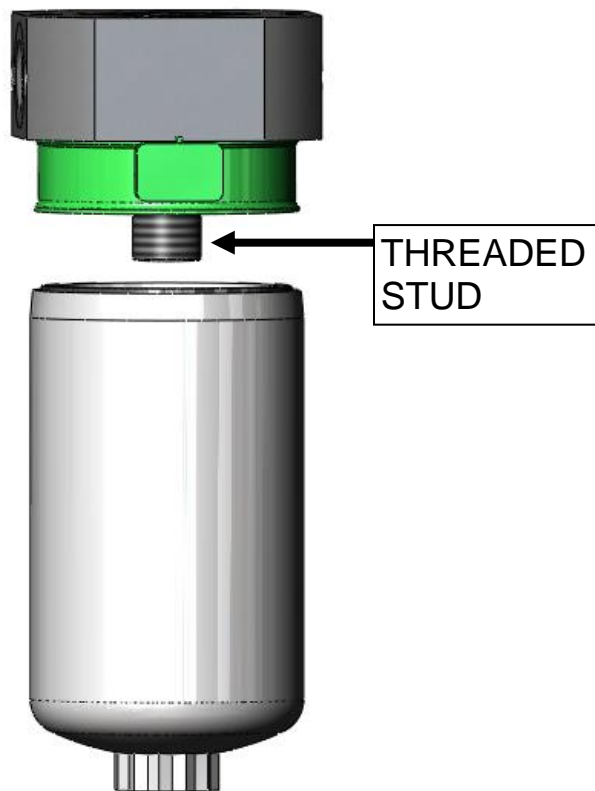

- 5.** Insert heater wiring harness wiring connector into heater.

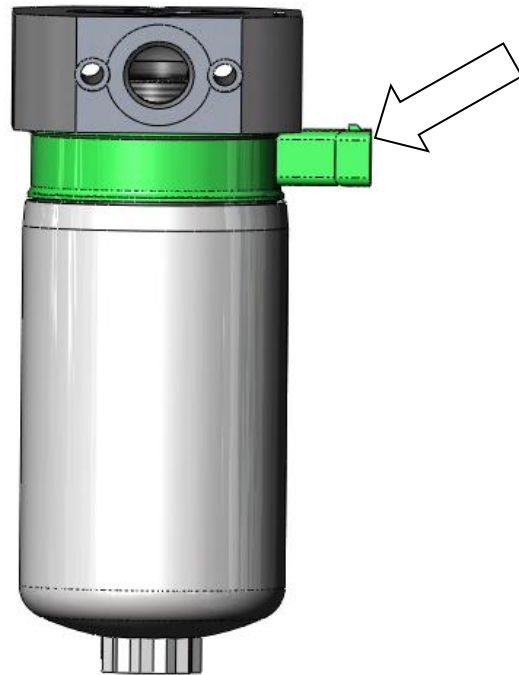

Install the supplied wiring harness by disconnecting the existing FLOWMAX power harness.

