



INSTALL MANUAL



Designed for the **7.3L** Powerstroke

1994-1997 Ford Powerstroke **BD Turbo Mount Vacuum Exhaust Brake** **Part# 2033143**

OWNER'S MANUAL – LEAVE IN GLOVE BOX
Installation Manual Part # I2033143

-- TABLE OF CONTENTS --

Welcome	3
Kit Contents	3
Pre-Installation	3
Special Tools Required	3
Accessories	3
Notes On Connectors	4
Exhaust Brake Installation	5
Valve Installation	5
SPOOL VALVE INSTALLATION.....	8
DFIV Installation	9
Cruise Control Disconnect Wiring (if equipped)	10
Optional Shifter Switch	11
Optional Manual Shifter Switch (Rocker Switch Style)	12
Battery Reinstall	13
DFIV Calibration	13
Testing	14
Maintenance	14
Spool Valve Maintenance	15
Disassembly	15
Cleaning	15
Re-assembly	15
Testing	16
Helpful Hints	16
Operating Guidelines	17
Vacuum Brake Troubleshooting Guide	19

WELCOME

Thank you for purchasing a BD Engine Exhaust Brake. Your kit should have the items mentioned for your installation. Please check to make sure that you have everything. This manual is to aid you with your installation and operation of your braking unit. We strongly suggest that you write down the kit part number and serial number in the space provided on the front page and keep this manual for any future reference.

KIT CONTENTS

2033143 – Ford 7.3L Powerstroke Exhaust Brake

Part #	Qty.	Description
2133043	1	Valve Assembly
1230043	1	Control Kit
1230430	1	Vacuum Spool Valve Kit
1321039	1	DFIV Application Kit

PRE-INSTALLATION

To prevent damage to electronic components, it is recommended that you disconnect both negative battery terminals before starting.

Please read this manual thoroughly before installing this exhaust brake.

SPECIAL TOOLS REQUIRED

- Measuring tape or ruler
- Drill with 1/8", 3/16" bits and Unibit
- Sawsall or hacksaw
- Crimping Pliers
- Test light
- 1/4" Drive Socket Set
- Small bladed flat tip screwdriver
- Welder
- 5/16" 12pt. Half-Moon Wrench
- 5/16" 12pt. Swivel Socket

ACCESSORIES

Description	Part #
Manual Transmission Shifter Switch Kit	1300240 / 1030910
AutoLoc Convertor Lock-up Kit	1030390
Torqloc Convertor Lock-up Kit	1030395
Brake Pressure Gauge Kit	1030050
Exhaust Temperature (Pyrometer) Gauge Kit	1030512
Boost Pressure Gauge Kit	1030570
Transmission Gauge Kit	1030585

NOTES ON CONNECTORS

The kit includes a number of Posi-Tap™ connectors (Gray or Red/Black/Green or Yellow) to tap onto OEM wiring. It is important to select the correct color of connector so that it matches the gauge of the OEM wire that it is being installed on. Using the incorrect connector could cause an inadequate connection and/or the OEM wire could be severed.

OEM Wire	Posi-Tap™ Color
18-22ga	Gray or Red
12-18ga	Black
10-12ga	Green or Yellow

Though these connectors offer a quicker installation, the best option would be to solder the wires and isolate the joints with heat shrink or liquid electrical tape. Proper soldering techniques should be used to ensure adequate connections.

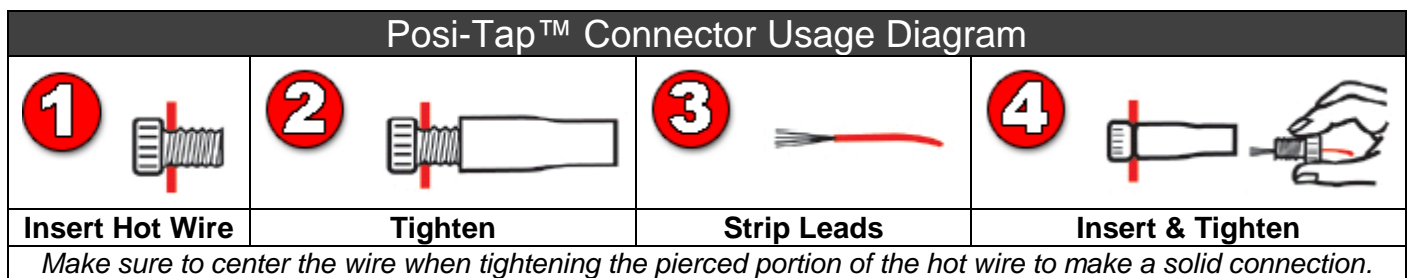

The ground terminals of the vehicle's batteries should be disconnected before performing any piercing/posi-tapping onto any ECM/PCM wire.

EXHAUST BRAKE INSTALLATION

VALVE INSTALLATION

Disconnect the negative terminals on both of the vehicle's batteries, and then disconnect the positive terminals. Remove the passenger side battery.

Remove the top cover housing of the engine and locate the engine-lifting eye by the turbo outlet and remove. Remove and retain the turbo exhaust clamp between the turbo and exhaust pipe. Loosen the 17mm nuts of the turbo down pipe (under cab) and push the pipe out of the way.

Remove the three mounting bolts of the outlet housing on the turbo. **NOTE:** The bottom-rear bolt, which cannot be seen, will require a 5/16" 12pt. half-moon wrench to loosen it, then taken out with the use of a swivel socket.

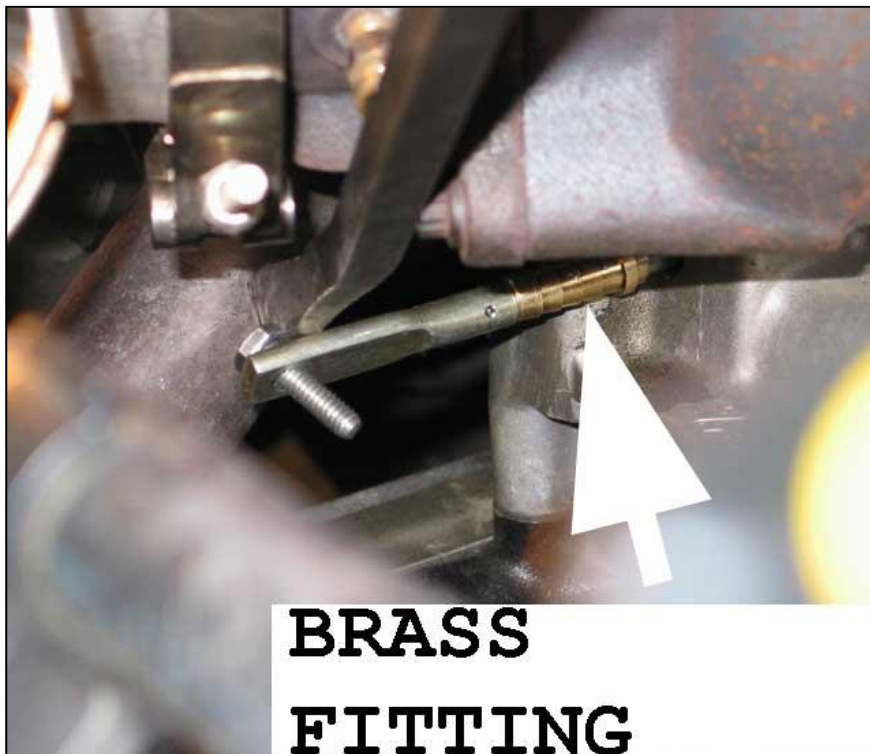

Disconnect the actuation rod from the bottom of the outlet housing by sliding back the ball joint cover and remove the turbo outlet housing. **NOTE:**

The clip that holds the rod to the outlet housing is similar to that found on carburetors.

To prevent the rod from hanging, which can cause the rod seal to leak due to vibration, install the supplied rod support fitting. This is a brass fitting that has a cut in it, which fits around the rod and holds the rod securely.

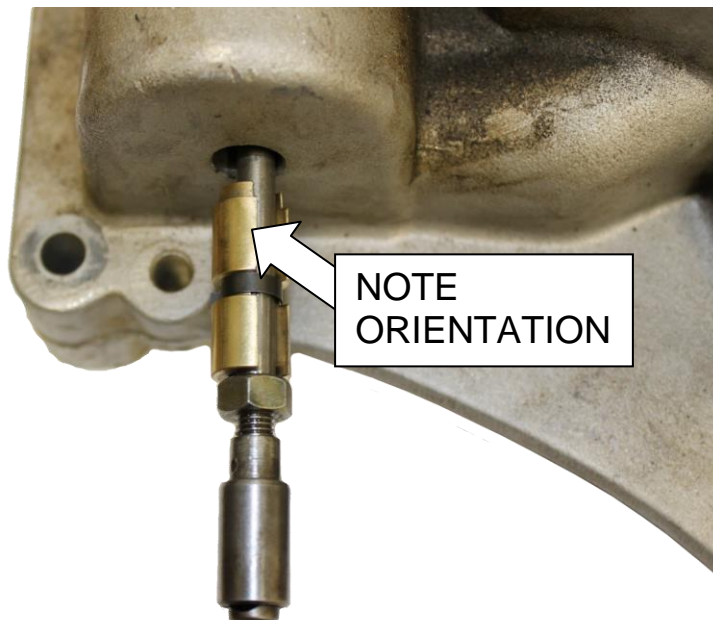

Give the clip a pinch before installing to ensure a strong fit.



The EBP Valve will not be required with the installation of the BD Exhaust Brake. It is recommended that the EBP Valve wiring harness be disconnected to prevent the actuator rod from moving to protect the seal.

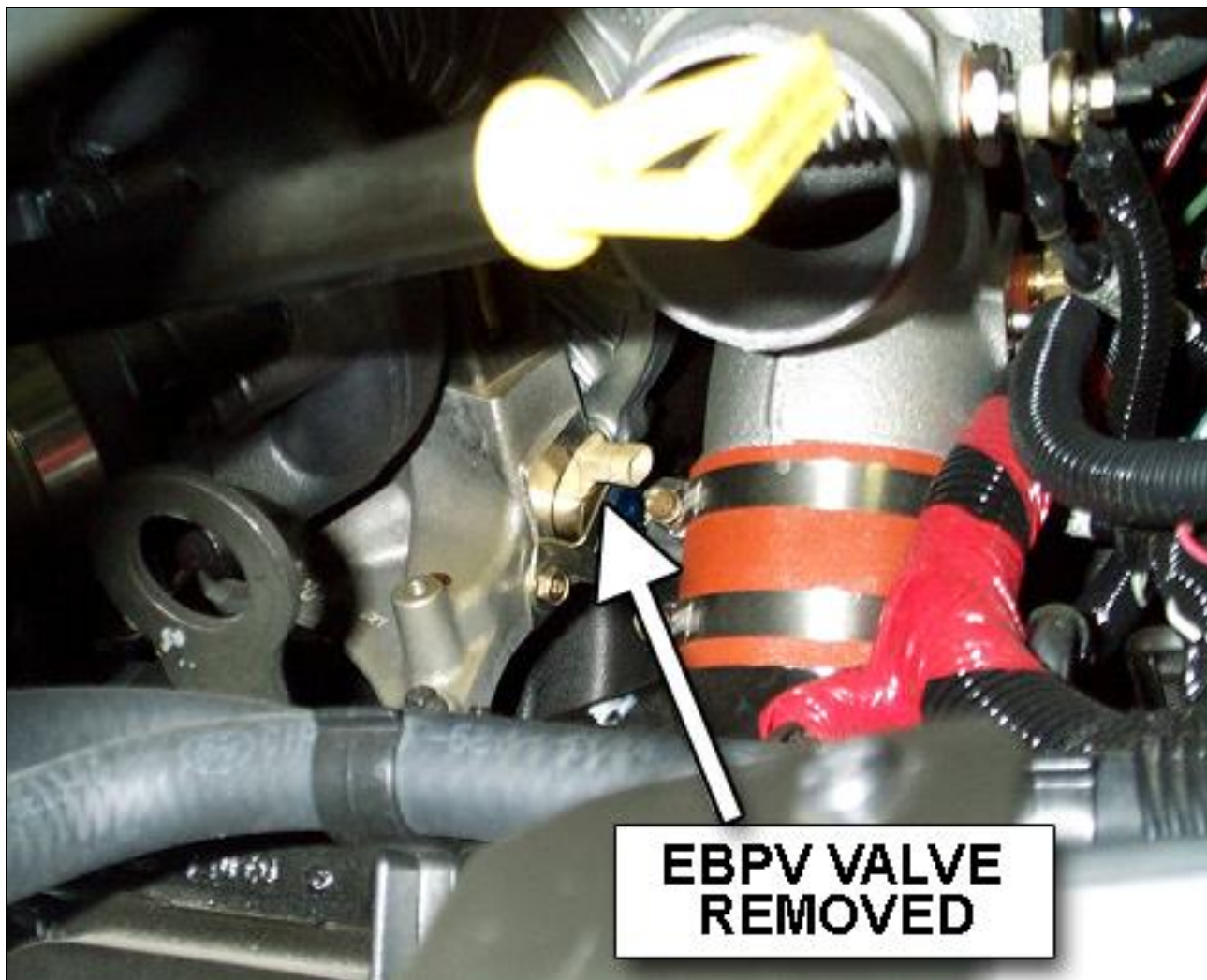

NOTE: ON CALIFORNIA MODEL VEHICLES THE EBP VALVE WIRING MUST BE CONNECTED TO ENSURE THE ECM DOES NOT SET AN ENGINE TROUBLE CODE.

Install the BD Brake Valve Assembly on the turbo using the original mounting bolts, first threading in the front bolt, then the top bolt and the bottom rear bolt last, and tightening all bolts.

Using the turbo exhaust clamp, secure the exhaust pipe to the Brake Valve and tighten the lower 17mm nuts of the down pipe.

SPOOL VALVE INSTALLATION

Remove the lower right bolt on the wiper motor and install the supplied stud in its place, with the long pointing end going in the hole. Mount the Spool Valve Assembly onto the stud, using the supplied lock nut, with the Spool Valve ground wire w/stud (eye-hole) connector under the nut.

The Spool Valve Assembly has two hoses attached to it; it is very easy to confuse these two so please pay close attention to the diagram below. Insert the first hose (marked on the diagram as #1) onto the quick connect fitting on the front blue cap of the Vacuum Cylinder on the Brake Valve Assembly, and the other hose (#2) onto the front quick connect fitting on the red cap. Make sure the hoses are out of the way of any moving or heated items on the engine.

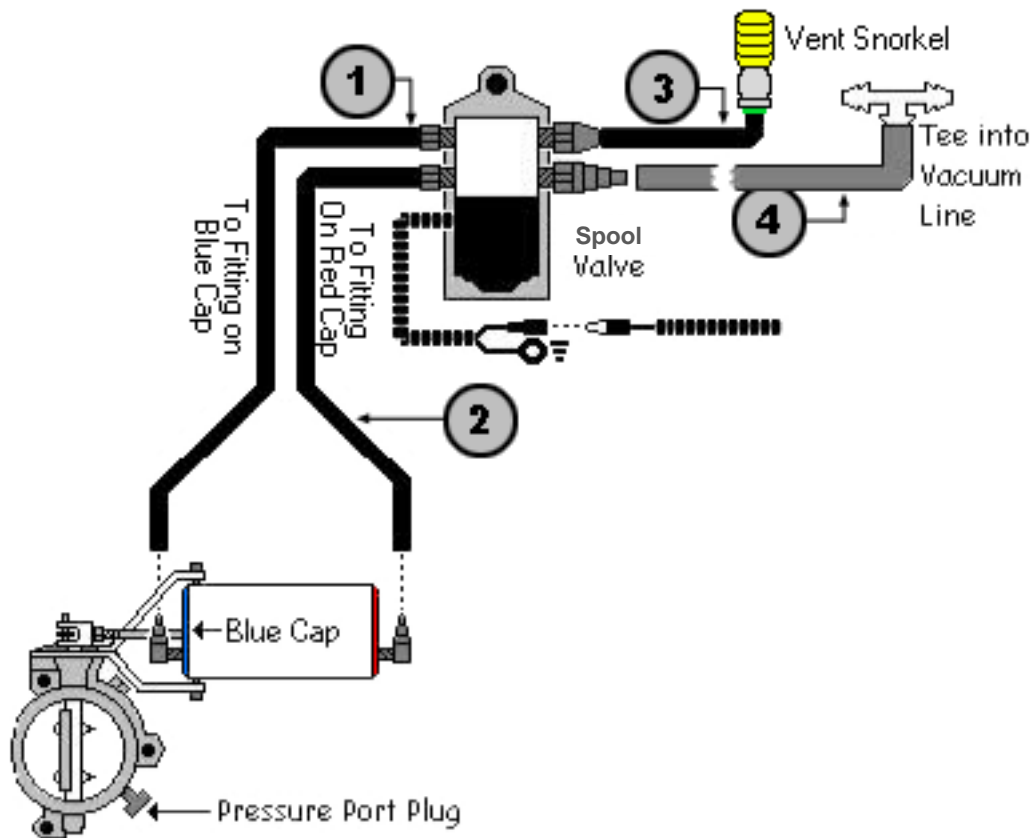

Find the hose running from the vacuum pump to the power brake booster. Cut this hose just before the vacuum manifold and install the 3/8" plastic tee (w/hose attached) to the two pieces of hose. Attach the free end of the supplied hose to the unused barb fitting on the Spool Valve (#4).

There is a loose section of plastic hose that came included with the spool valve kit with a plastic vent filter on it. Attach this to the Spool Valve (#3) and run to a dry location inside your cab. This vent prevents moisture from entering the Spool Valve.

DFIV INSTALLATION

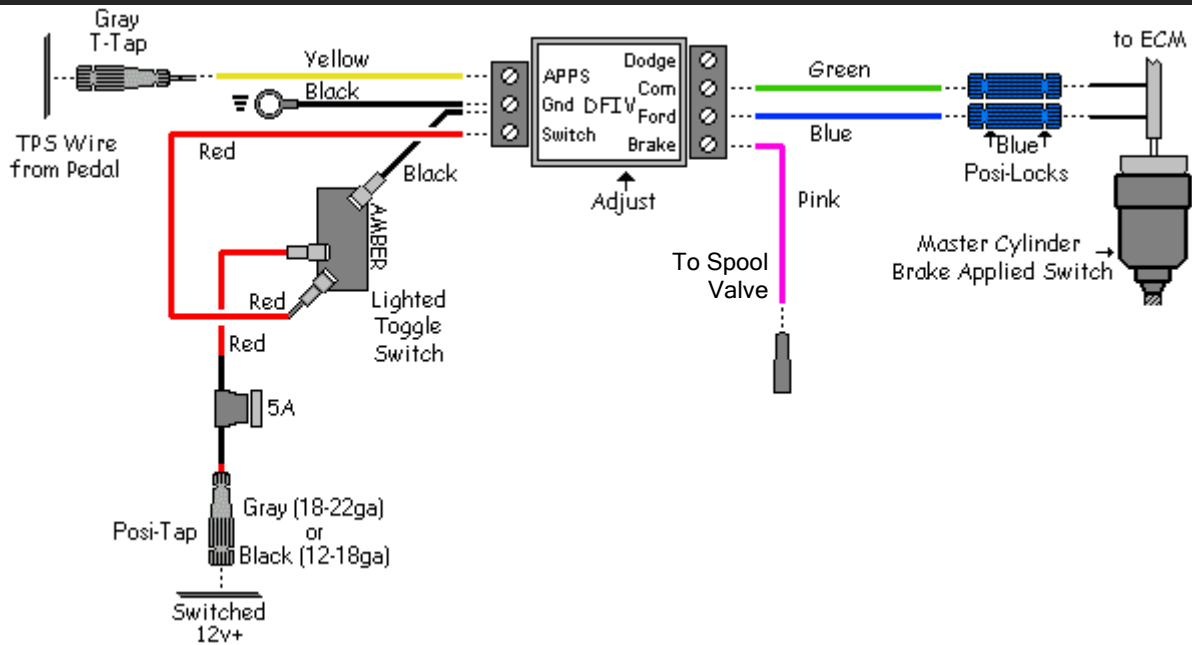

CAUTION: Before installing any wiring modifications or equipment ensure to disconnect the battery Ground (Negative) terminals on all the vehicle batteries as damage to the vehicle’s ECU and/or installed components may result.

Remove the lower section of the dash under the steering column, and mount the DFIV module to the cross member under the steering column. Connect the Black wire from the DFIV module to a good ground.

Locate the **Throttle Position Sensor (TPS)** at the throttle pedal and use a gray Posi-Tap connector to attach the Yellow wire from the DFIV module to the Gray/White tracer wire on the TPS.

Ensure the Green wire is connected to the ‘COM’ terminal of the DFIV module, the Blue wire is connected to the ‘FORD’ terminal of the DFIV module, and the Pink wire is connected to the ‘BRAKE’ terminal of the DFIV module. Also check to ensure all other wires at the DFIV module are secure.

NOTE: If the vehicle does not have Cruise Control, remove the Green and Blue wire from the DFIV and discard.

Run these wires through a grommet in the firewall making sure all wires are secured and away from moving parts and heat sources.

CRUISE CONTROL DISCONNECT WIRING (IF EQUIPPED)

NOTE: If the vehicle does not have Cruise Control, remove the Green and Blue wire from the install and discard. Skip to the Control Wiring section.

Consult the wiring diagram for proper connections and locate the Brake Applied Switch on the brake master cylinder.

Locate the Black w/Yellow wire at the Cruise Control Disable (Brake Applied) switch located on the brake master cylinder and expose the wiring approximately 4 to 6 inches from the switch to allow for a good length to work with.

NOTE: This wire may be a different color in various applications. If there is no Black w/Yellow wire going to this switch, use a test light to check which wire changes state (power to no power) when the brake pedal is applied.

Cut the black wire w/yellow tracer (BK/YL), strip both ends. Attach a blue Posi-Lock connector to each end of the wire. Run the green and blue wires from the DFIV to the Brake Applied Switch at the brake booster and cut off any excess.

Connect the green wire to one of the Posi-Locks and connect the blue wire to the other one. The order of these is not important, the DFIV just need to be wired in series. Refer to wiring diagram on the previous page.

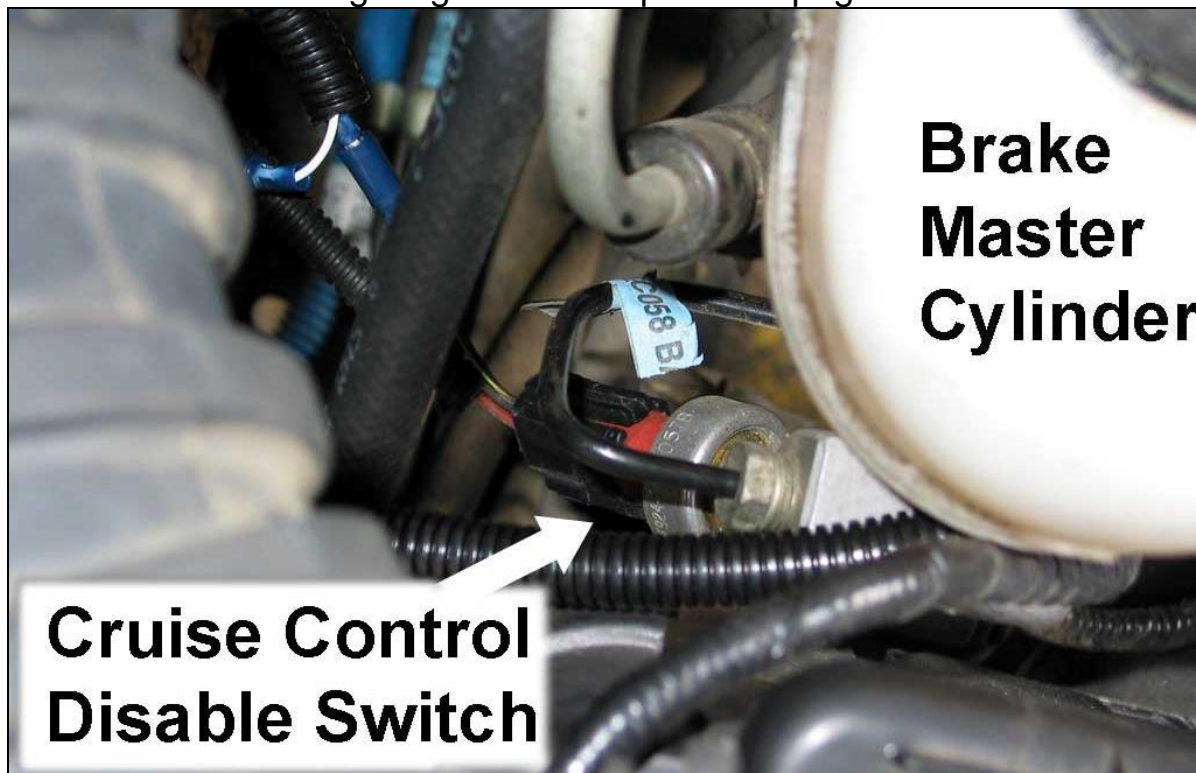

Run the pink wire from the DFIV to the Spool Valve and trim off any excess. Strip away some of the insulation and install a female bullet connector then plug the connector on the free Spool Valve wire. Secure all wires and hoses to ensure they are out of the way of moving and heated items.

OPTIONAL SHIFTER SWITCH

To install the optional Manual Shifter Switch Kit, mount the switch onto the shift lever using the clamp supplied. Run the cable down the shifter shaft, securing the cable with zip-ties or electrical tape, and run under the carpet to the firewall and under the dash to the DFIV, leaving enough slack for proper shifting of the transmission lever and to prevent any rubbing of wire.

At the end of the cable, cut off any excess and strip away about 1 to 2 inches of the black rubber covering, exposing the black and white (or Green) wires then strip the insulation from the ends of the two wires.

Connect the White (or Green) wire to the "Switch" terminal on the DFIV Module.

Connect the other wire to the Grey w/yellow tracer wire in pin #17 in the fuse panel using one of the supplied positaps.

Locate one of the ignition switch power fuses in the fuse panel underneath the steering column. Install the supplied fuse tap onto this fuse, crimp a female blade connector onto the black wire of the push-pull switch and plug the black wire onto the fuse tap.

Also provided in the kit is a Posi-Tap connector which can be used as an alternative to the fuse tap and flag connector. You can use the Posi-Tap to tap onto the 12 volt switched ignition wire that you used to power the DFIV. Or, locate one of the ignition switched red-black tracer wires under the steering column (one is a 10/12ga and the other is a 14/16ga) and connect an appropriate Posi-Tap connector to it (green for 10/12ga and black for 14/16ga wire). Connect the black wire of the push-pull switch to the Posi-Tap



OPTIONAL MANUAL SHIFTER SWITCH (ROCKER SWITCH STYLE)

Mount the shifter switch onto the shift lever using the clamp supplied (either 5/8" or 3/4"). Run the electrical cable down the shifter shaft, securing the cable with zip-ties or electrical tape, and run it under the carpet to the firewall and under the dash to the relays, leaving enough slack for proper shifting of the transmission lever and to prevent any rubbing of wire.

At the end of the cable, cut off any excess and strip away about 1-2" of the black rubber insulation exposing the black, white and green wires, then strip the insulation from the ends of the three wires.

Connect the green 12V output green wire to the "Switch" input terminal on the DFIV.

Attach the 5/16" ring connector to the black ground wire and attach it to a good ground nearby, or to the "ground" terminal of the DFIV.

Locate one of the ignition switched power fuses in the fuse panel underneath the steering column. Use the supplied fuse tap to supply ignition switched power to the "Keyed 12 Volts" (white) wire of the rocker switch assembly.

Also provided in the kit is a Posi-Tap connector which can be used as an alternative to the fuse tap and crimp connector. You can use the Posi-Tap to tap onto the 12 volt switched ignition wire that you used to power the DFIV. Or, locate one of the ignition switched red-black tracer wires under the steering column (one is a 10/12ga and the other is a 14/16ga) and connect an appropriate Posi-Tap connector to it (green for 10/12ga and black for 14/16ga wire). Connect the white wire of the rocker switch assembly to this Posi-Tap.

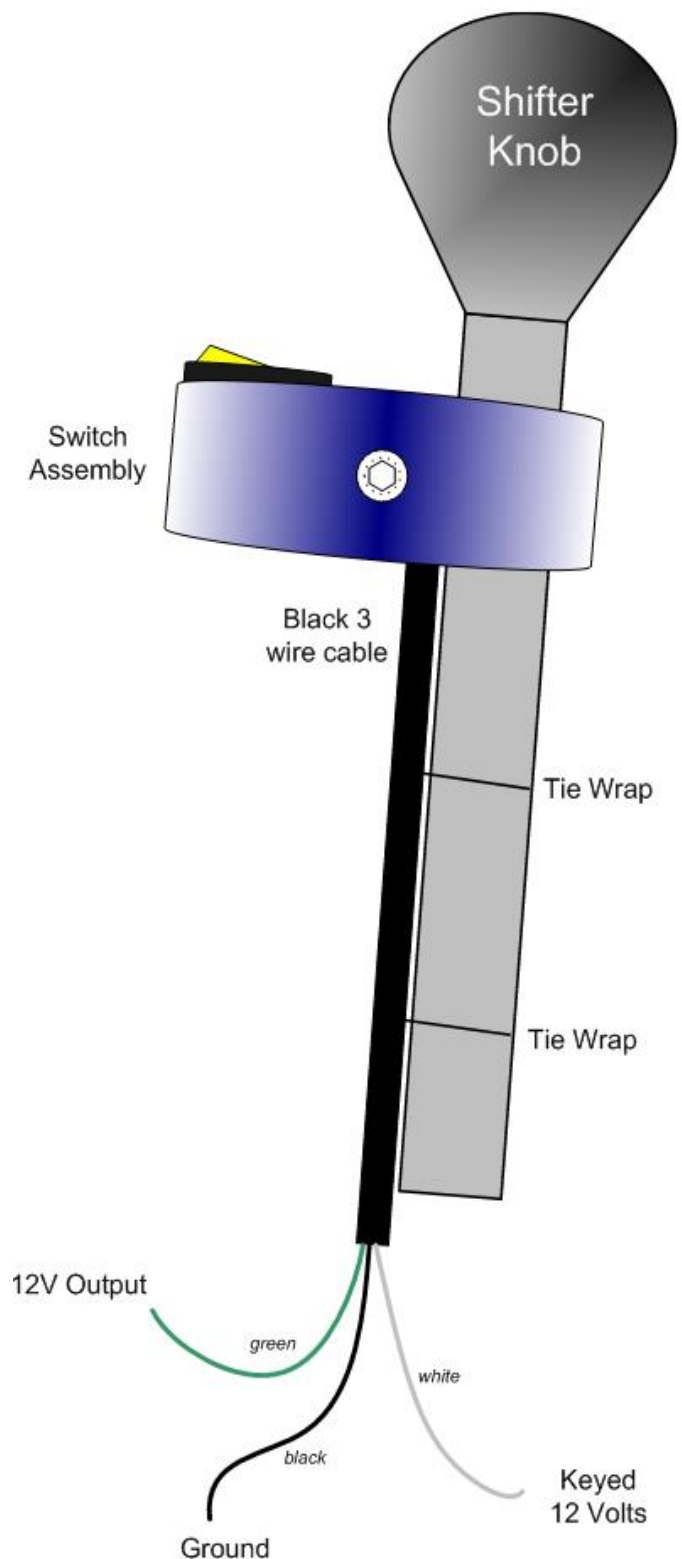

BATTERY REINSTALL

Reinstall the passenger side battery. Reconnect the positive terminals on both batteries then reconnect the negative terminals.

DFIV CALIBRATION

Ensure the connections of the corresponding wires to the DFIV Control Module are correct as shown in the wiring diagram.

To achieve the correct setting for the activation of the exhaust brake in relation to the throttle pedal the DFIV Module must be calibrated for your vehicle.

Connect one end of a test light to the "BRAKE" terminal of the DFIV module and the other end to a good ground.



With the throttle at idle, start the engine and turn on brake switch. Then, using a small flat bladed screwdriver, turn the small adjusting screw in the DFIV Module counterclockwise or clockwise until the test light JUST turns on.

CAUTION: THE ADJUSTING SCREW IS A MICRO-SWITCH THAT IS VERY DELICATE, SO TURN USING SMALL ADJUSTMENTS.

Test by revving up the engine to approximately 1200 RPM and releasing the throttle. As the accelerator pedal is applied the test light should turn off just before the engine starts to rev, indicating proper calibration of the DFIV Module with the APPS.

Then the test light should activate again when the throttle pedal returned to idle. If not, readjust the DFIV Module so that it does. Reinstall lower dash cover.

TESTING

Start the engine and turn on the brake toggle / shifter switch. The brake should activate at idle. Press the accelerator pedal to rev the engine, the brake valve should open as the pedal is pressed and close again when the pedal returns to idle.

Take the truck for a test drive. Check that with the switch in the On position Cruise Control does not engage. If you turn the switch Off then Cruise Control should work normally.

The brake will need to be adjusted for the vehicle. If more holdback performance is required with the vehicle loaded, adjust the rod on the Vacuum Cylinder to close off the valve tighter. (**NOTE:** Only slight adjustments are required to gain desired effect, and, all adjustments should be done with vehicle turned off.)

A standard pressure gauge can be used to make the necessary adjustments to the brake valve. You can use the port provided on the exhaust brake valve (there is a brass plug in it, see Plumbing Diagram on page 8) or you can use the factory back pressure sensor bung located behind the belt idler pulley. Adjust the brake to reach approximately 10-12 lb. while the engine is at idle. **NOTE:** Over the two weeks, the back pressure at idle may rise due to initial carbon build up, which the brake valve will need to be adjusted again.

Check for any exhaust leaks and recheck all connections and hoses for security and interference from moving or heated items. After about 100 miles (160 km), re-torque the turbo exhaust clamp and flange bolts.

MAINTENANCE

To extend life of the valve assembly, do not operate your vehicle for extended periods of time without activating the brake. On a twice-yearly interval, check and adjust the brake pressure to 10-12lbs. while the engine is at idle. The hoses, wires, fittings and clamps should be inspected on a regular basis for any deterioration, damage or leaks.

If the brake ceases to work, then push in the black button on the top of the valve while the engine is running. If the brake engages, then check that there is power at the fuse, all electrical connectors are firmly connected, all grounds are good, and that there is power output at the pink wire coming through the fire wall, connecting to the control assembly, when the throttle pedal is at rest.

If the brake failed to engage with black button pressed in while the engine is running, check for vacuum pump operation and check for leaks. Check for smooth operation when manually pulling and pushing of the lever on the brake valve (with the engine turned off). The valve may have to be taken apart and cleaned.

Following the diagrams in this manual, tracing hoses and wiring, checking continuity through electric components, or checking for any lines that are disconnected, should solve any problems that may arise.

SPOOL VALVE MAINTENANCE

DISASSEMBLY

- Remove the two coil screws.
- Remove the two rear plate screws.
- Pop out the white and black bumpers, springs, and O-rings.
- Remove the spool and sleeve assembly from the valve body with a plastic or wooden rod approximately the same size as the outside diameter of the sleeve.

CLEANING

- Clean the spool and sleeve with some WD40 and compressed air.
- Inspect the spool and sleeve for any damage and inspect O-rings.
- The spool should move freely within the sleeve.

RE-ASSEMBLY

- Reinstall the rear plate, O-ring, and black bumper onto the body.
- Gently slide the sleeve into the body cavity by pushing and turning at the same time.
- Drop the spring into the sleeve.
- Gently insert the spool into the sleeve with a slow, turning action.
- NOTE: The residual WD40 should be enough lubricant for assembly.
- Check to ensure that there is very little resistance felt when it's inserted. NOTE: If any resistance or binding is noted, remove the spool and try again.
- Once the spool is inserted and moving freely, reattach the coil, white bumper, and O-ring.

OPERATING GUIDELINES

Thank you for taking interest in the BD Engine Exhaust Brake. As a driver, you probably already know the need for extra braking power that your vehicle requires on the hills and long grades. With loads being towed behind you, the extra push when slowing down or maintaining speed on downward grades can prove to be a great strain on your vehicles hydraulic braking system, even to a point of “burn-up”.

These guidelines were designed to offer you a better understanding of the benefits of exhaust brakes and are partly based upon material developed by the U.S. Department of Transportation National Highway Traffic Safety Administration.

The emphasis on today’s vehicles is to give the consumer a product that can give them usable power with fuel efficiency. But, in the transition, the vehicles have lost their natural braking power, making it more easy for the vehicle to continue to roll and harder to stop. Of course, this gets more noticeable with the increase of weight, on or behind the vehicle.

This is where an exhaust brake becomes a useful tool in increasing the driveline drag of the vehicle without the use of the hydraulic brakes; A tool that with maximum use or even occasional use, can reduce wear on hydraulic braking parts and at the same time increase safety.

The BD Exhaust Brake can be used to help maintain a controlled vehicle speed on a downward grade, as well as slowing the vehicle down for such times as turns or exit ramps, without using your hydraulic brakes. **But, the exhaust brake cannot be used as a parking brake or will not bring your vehicle to a complete stop.**

When you ride your hydraulic brakes, make hard stops or have poorly adjusted brakes, it creates high temperatures and as your brakes get hotter, there is more chance for brake fading and/or complete failure.

By using a BD Exhaust Brake, the life and effectiveness of your hydraulic brakes will increase. This is because of the decreased use of the hydraulic brakes in situations like hills, the wear factor is reduced and there is less opportunity for your hydraulic brakes to heat up which would reduce the efficiency.

With terrain that is a series of up and down grades, the BD Exhaust Brake will aid in reducing exhaust valve warpage. Because of the power needed to pull your vehicle and load up a hill, this generates a lot of heat. When you have reached the crest of the hill and are now coasting down the other side, the heated valves are too quickly cooled. With the exhaust brake engaged, the heat loss to the valves will be reduced, which can prevent valve warpage.

When the toggle switch is turned to the “On” position, the valve is activated every time the driver takes his foot off of the throttle pedal. When the driver puts pressure

back on the throttle pedal, the relay is activated and the valve opens again. Exhaust brakes are designed to operate with the throttle at idle, not to be used in conjunction with cruise controls, and not designed to aid in gear shifting. Such cases could cause damage to engine and/or the exhaust brake. The vehicle may require shifting down to achieve the necessary retarding force.

Automatic transmissions with lock-up clutches in the convertors can achieve the best retarding force with the use of a clutch control device (i.e. AutoLoc). During cold weather engine start up, turn the brake on at idle while warming up the vehicle. This brings up the engine to normal operating temperature in much less time.

Incorporated with the BD Exhaust Brake, there is a pressure regulating system that will control the created backpressure. If the backpressure reaches the set limit, the exhaust valve will open slightly to relieve the excess pressure.

The brake pressure, at idle, is required to be checked and adjusted at time of installed, two weeks after installed, and on a regular twice a year interval.

Use a standard pressure gauge and the pressure port on the exhaust valve, the brake pressure at idle must be set between 10 and 12lbs.

The best scenario for exhaust braking is when going down hill, select a gear that lets you maintain a constant speed with little or no use of the hydraulic brakes, or, the same gear that would be used to go up the same grade of hill. This also depends on the weight, load or road conditions that the vehicle will come upon.

So, in summary, by using the BD Exhaust Brake, you reduce the need for use of your hydraulic brakes in situations where you need to slow down or maintain (i.e. hills, off ramps, corners, approaching speed changes or traffic lights). By reducing the use of your hydraulic brakes in these situations, this will reduce the heat build up as well as wear and damage to linings and drums.

When you reduce these factors you save your hydraulic brakes for when you really need them (i.e. for stopping or emergencies). The BD Exhaust Brake is not a substitute for your hydraulic brakes and, cannot correct or compensate for poorly maintained or misadjusted brakes. But, when you need to slow down or maintain a constant speed, the BD Exhaust Brake will be a valuable and effective tool. Exhaust Brakes are more efficient at preventing than correcting an over-speed condition.

To increase the life of your exhaust brake we recommend daily operation. This could simply be switching it on and off a couple times a day. This will prevent the butterfly from sticking due to carboning up.

VACUUM BRAKE TROUBLESHOOTING GUIDE

This guide assumes that your exhaust brake system is using a DFIV. If your system uses a microswitch for throttle activation, the operation of the spool valve is the same as with the DFIV.

When I let off the throttle nothing happens.	<u>No</u>	<u>Yes</u>
Is the DFIV powering its "brake" output when the throttle is at idle and brake switch and ignition are both on?	Check if DFIV has good power, ground and throttle signal. Check DFIV adjustment. If these things check out, but the DFIV won't power the "brake" output, the DFIV is likely faulty.	The spool valve is probably stuck. Check that it has good vacuum supply. Vacuum should switch from one outlet hose to the other when the valve actuates. If it doesn't, you can dismantle and clean the spool valve. See Spool Valve Maintenance section in this manual.
The brake comes on but there's little or no holdback	<u>No</u>	<u>Yes</u>
See if torque converter is staying locked up during deceleration. If not, the engine RPM will fall to idle when the throttle is released. The brake will be ineffective without the torque converter locked up. Check off idle brake pressure. (See back pressure chart) Are you getting maximum allowable backpressure?	Check for exhaust leaks. A small leak can result in a significant decrease in back pressure. If no leaks are found check for vacuum leaks in brake system and trucks factory vacuum system.	Try down shifting more aggressively. More RPM will give more holdback. Transmission or torque converter could be slipping internally.
Everything seems to work, but the brake valve won't open/close.	<u>No</u>	<u>Yes</u>
Check that vacuum is reaching brake vacuum cylinder?	Spool valve is likely stuck. See Spool Valve Maintenance section in this manual.	Cylinder or brake valve are seized. Remove the clevis pin on the end of the cylinder rod & see if the valve lever can be moved freely.
The valve lever can be moved freely?	Try dismounting the brake & cleaning the carbon out of it. If this does not work the brake valve will need to be replaced.	The cylinder is stuck and will need to be replaced.
The brake won't close at idle but comes on when I press the throttle	The vacuum hoses to the cylinder are reversed. Swap them front-to-back on the cylinder and everything should work.	

Thank you and happy motoring.