



BD Cool Down Timer 2

Application Chart --

<u>1081160</u>	Dodge Cummins (5.9/ 6.7)	1994-2005
	Ford F Series (6.0/ 6.4/ 6.7/ 7.3)	1994-2016
	GMC/Chevy Duramax (6.6)	2001-2014
<u>1081160-D1</u>	Dodge Cummins (5.9/ 6.7)	2006-2009
<u>1081160-D2</u>	Dodge Cummins (6.7)	2010-2012
<u>1081160-D3</u>	Dodge Cummins (6.7)	2013-2016

***** Please read this manual before starting installation. *****

OWNER'S MANUAL - LEAVE IN GLOVE BOX
Install Manual Part # I1081160



TABLE OF CONTENTS





Kit Contents	3
Required Tools.....	5
Options.....	5
Compatibility	5
Notes On Connectors	5
What Is The Cool Down Timer 2 (CDT2)?	6
How Does The Cool Down Timer 2 Work?	6
Precautions	6
Safety Features	7
Vehicle Wiring	8
NOTES	9
GENERAL WIRING	9
FORD POWERSTROKE WIRING DIAGRAM	10
DODGE CUMMINS WIRING DIAGRAM	13
2004½ - 2005 Dodge Trucks Wastegate Solenoid Power Wiring	14
Dodge 2006-2009	15
Dodge 2010-2012	16
Dodge 2013-2016	17
DURAMAX WIRING DIAGRAMS	20
Thermocouple Wiring (Not needed if monitoring with Time vs. Temp)	24
Direct Thermocouple Connection	24
Amplified Pyrometer Gauge Kit	24
Conventional Non-Amplified Pyrometer Kit	25
Temperature Adjustment	25
Time Adjustment	26
Communication / Operation Lights	27
Mounting	27
Technical Assistance	27
Wire Color Glossary	27
Troubleshooting	28

Kit Contents

Please check to make sure that you have all the parts listed in this kit before you begin to install this kit.

BD Cool Down Timer 2 (P/N# 1081160)



1801160	1801161	1300131
		
<i>CDT2 Control Module</i>	<i>CDT2 Wiring Harness</i>	<i>Cable Tie (Medium)</i>
Qty: 1	Qty: 1	Qty: 10

1300348	1300349	1300350	1801151
			
<i>Posi-Tap Connector (18-22ga – Red in color)</i>	<i>Posi-Tap Connector (12-18ga – Black in color)</i>	<i>Posi-Tap Connector (10-12ga – Yellow in color)</i>	<i>Ring Connector</i>
Qty: 5	Qty: 2	Qty: 2	Qty: 2







DODGE 2006-2009 (P/N# 1081160-D1)

1801160	1801162-1	1300348	1300131
			
<i>CDT2 Control Module</i>	<i>2006-09 Harness</i>	<i>Posi-Tap Connector (Red)</i>	<i>Cable Tie (Medium)</i>
Qty: 1	Qty: 1	Qty: 1	Qty: 5

DODGE 2010-2012 (P/N# 1081160-D2)

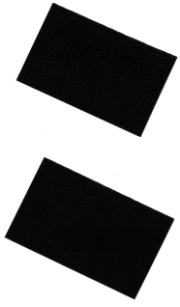
1801160	1801162-2	1300131
 <p>A blue rectangular control module with two green terminal blocks on top. The front panel has various labels for inputs and outputs, including 'RELAY OUTPUT (NO)', 'RELAY COMMON', 'AUX OUT', 'TRANS PUMP (DODGE)', 'KEEP ALIVE', 'ADJUSTMENT', 'GROUND', 'THERMOCOUPLE +', 'THERMOCOUPLE -', 'BRAKE INPUT', 'KEY INPUT', 'AUX INPUT', and 'CONSTANT POWER'. The 'BO DIESEL' logo is also visible.</p>	 <p>A black braided cable harness with a multi-pin connector on one end and several individual wires on the other.</p>	 <p>A single black plastic cable tie.</p>
<p>CDT2 Control Module</p>	<p>2010-2012 Harness</p>	<p>Cable Tie (Medium)</p>
<p>Qty: 1</p>	<p>Qty: 1</p>	<p>Qty: 5</p>

DODGE 2013-2016 (P/N# 1081160-D3)

1801160	1801162-3	1300131	1330051
 <p>Identical to the module in the previous section.</p>	 <p>A black braided cable harness with a multi-pin connector on one end and several individual wires on the other.</p>	 <p>A single black plastic cable tie.</p>	 <p>Two black rectangular pieces of Velcro.</p>
<p>CDT2 Control Module</p>	<p>2013-2016 Harness</p>	<p>Cable Tie (Medium)</p>	<p>Velcro (3" L)</p>
<p>Qty: 1</p>	<p>Qty: 1</p>	<p>Qty: 5</p>	<p>Qty: 2</p>
1607313	1300348	1607317	1307310
 <p>A coil of light blue 18-gauge wire.</p>	 <p>A red plastic Posi-Tap connector.</p>	 <p>A coil of yellow 18-gauge wire.</p>	 <p>A coil of red 18-gauge wire.</p>
<p>Wire; 18GA – Lt Blue</p>	<p>Posi-Tap (Red)</p>	<p>Wire; 18GA - Yellow</p>	<p>Wire: 18GA - Red</p>
<p>Qty: 60"</p>	<p>Qty: 1</p>	<p>Qty: 120"</p>	<p>Qty: 120"</p>

Required Tools

- Wire strippers
- Wire crimpers
- Small Flat Nose Screwdriver
- Philips Screwdriver
- Pliers (Needle / Flat Nose)
- Soldering Gun (*Optional*)
- Heat Shrink / Liquid Tape (*Optional*)

Options

- 1081151 Probe (Thermocouple) Kit

Compatibility

This Cool Down Timer will work with virtually all “K” type of thermocouples offered by companies such as ISSPRO or EGT.

Notes On Connectors

The kit includes a number of Posi-Tap™ connectors (Gray or Red/Black/Green or Yellow) to tap onto OEM wiring. It is important to select the correct color of connector so that it matches the gauge of the OEM wire that it is being installed on. Using the incorrect connector could cause an inadequate connection and/or the OEM wire could be severed.

OEM Wire	Posi-Tap™ Color
18-22ga	Gray
12-18ga	Black
10-12ga	Yellow

Though these connectors offer a quicker installation, the best option would be to solder the wires and isolate the joints with heat shrink or liquid electrical tape. Proper soldering techniques should be used to ensure adequate connections.

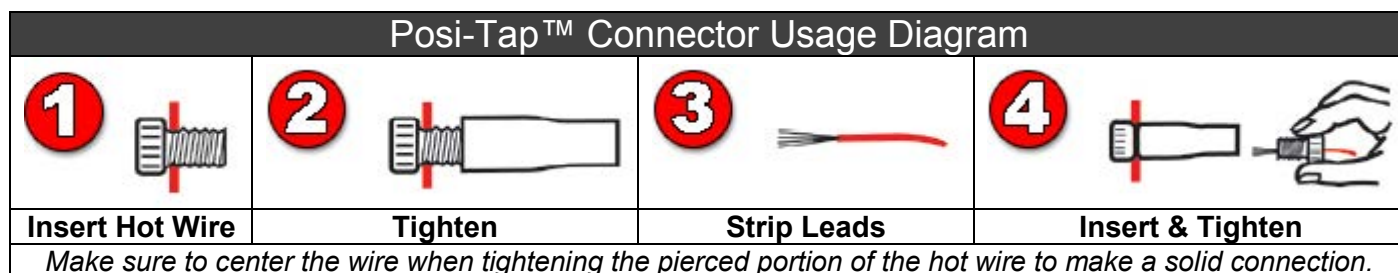

The ground terminals of the vehicle’s batteries should be disconnected before performing any piercing/posi-tapping onto any ECM/PCM wire.

What Is The Cool Down Timer 2 (CDT2)?

The CDT2 is designed to keep the engine running when the ignition is turned to prevent turbocharger bearing failure that could occur when the engine is shut down and the turbocharger is still hot.

The turbocharger is lubricated and cooled by the engine oil and when the engine is turned off, that oil supply is cut off. If the turbocharger is still hot at shutdown, the remaining oil in the bearing housing will overheat, causing coking of the turbocharger bearings. Over time this coking causes both premature bearing wear and reduced oiling of the bearings. Allowing the engine to idle gives the turbocharger time to cool down before stopping the supply of lubrication oil which can prolong turbocharger life.

Turbochargers rotate at high speeds, often in excess of 100,000rpm under load. If the engine is shut down too quickly after use, the residual oil in the bearing housing will not be sufficient for lubrication and may cause premature bearing wear. A short period of engine idling after use will help to ensure the turbocharger has reached a minimum operating speed before shutting down.

How Does The Cool Down Timer 2 Work?

When the key is turned off, the CDT2 module will keep the power supplied to the ECM/PCM, which will in turn keep the engine running. On late model vehicles the CDT2 keeps most or all of the vehicle ignition system and accessories powered until engine shutdown, on early model vehicles only the engine will remain running.

The CDT2 can shut the engine down once the exhaust temperature reaches a set temperature as this is the most effective method of determining a safe shut off point. The CDT2 can also be set to keep the engine on for a fixed time after the key is removed. The suggested shutdown exhaust temperature is below 400°F.

When using the CDT2 set for exhaust temperature, the module must be connected to a thermocouple which may be purchased separately or may be connected to an existing temperature sensor already installed in the vehicle.

Precautions

The CDT2 by default will **not** lock the doors or set the alarm. With most vehicles, once you shut the door you can use the keyless remote or key to lock the doors.

Most OEM and aftermarket alarms will have to be activated after the CDT2 has shutdown the engine. Due to the wide variety of the alarms and immobilizers, it is best to test the

system(s) thoroughly to ensure proper procedures of activation or use in conjunctions with the CDT2.

The “Relay Output (NO)” and the “Relay Common” terminals can be configured to lock the doors automatically. Depending on the vehicle and the method of locking the doors you can wire either a Ground or 12V source to the “Relay Common” terminal. When the CDT2 shuts down the “Relay Common” terminal will be pulsed out to the “Relay Output (NO) terminal. See the below wiring diagram. Note BD cannot provide support on this option.

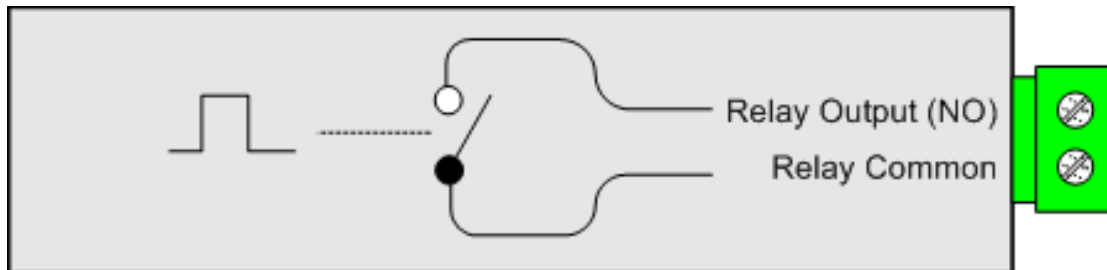

Proper parking procedures should be adhered to before leaving the vehicle including the engagement of the parking brake. Children or animals should not be left unattended in the vehicle while the CDT2 is keeping the vehicle running.

Safety Features

The CDT2 module has a few safety features built-in that the driver should be aware of. If for some reason the exhaust gas temperature does not fall below the shutdown setting within five (5) minutes from the key being turned off, the CDT2 will automatically shutdown the engine.

As well if the engine starts to initiate a REGEN cycle causing the EGT's to rise the CDT2 will shut the truck off.

The CDT2 module is also designed to monitor the vehicle's hydraulic brakes when it is connected to the brake pedal switch via the Brake Pedal terminal on the module. While the CDT2 module is keeping the engine alive (ignition key turned off and exhaust gas temperature above the shutdown setting), if the brake pedal is depressed the CDT2 will shutdown the engine. This was implemented to protect the vehicle from being stolen when the engine is in cool down mode; eventually the brake pedal would have to be pressed which will shutdown the engine preventing the thief from easily driving away with the vehicle. This is also useful in situations where the engine needs to be shutdown immediately or is desired to be shutdown sooner.

Vehicle Wiring

Using the following diagrams applicable to your vehicle, tap onto the vehicles wires using the appropriate sized Posi-Tap™ connector (not necessary if soldering the connections). All the vehicle wires are located under the dash where the module will be located.

Excess wire can be trimmed but please keep in mind that the module may have to be accessed to adjust the shutdown temperature so we suggest leaving enough slack to perform this function.

Connect to the appropriate terminals as per the charts and diagrams. Tighten each terminal by turning the terminal screws clockwise until the wire is secure.

When connecting the wires to the module, leave enough slack so that the module can be accessed to make temperature or time adjustments.

NOTES

Please be advised that when the engine is in cool down mode (CDT2 is active) a number of trouble lights or message center errors maybe displayed. This is completely normal and should not be a concern. The vehicle will function normally once the key is inserted again.

GENERAL WIRING

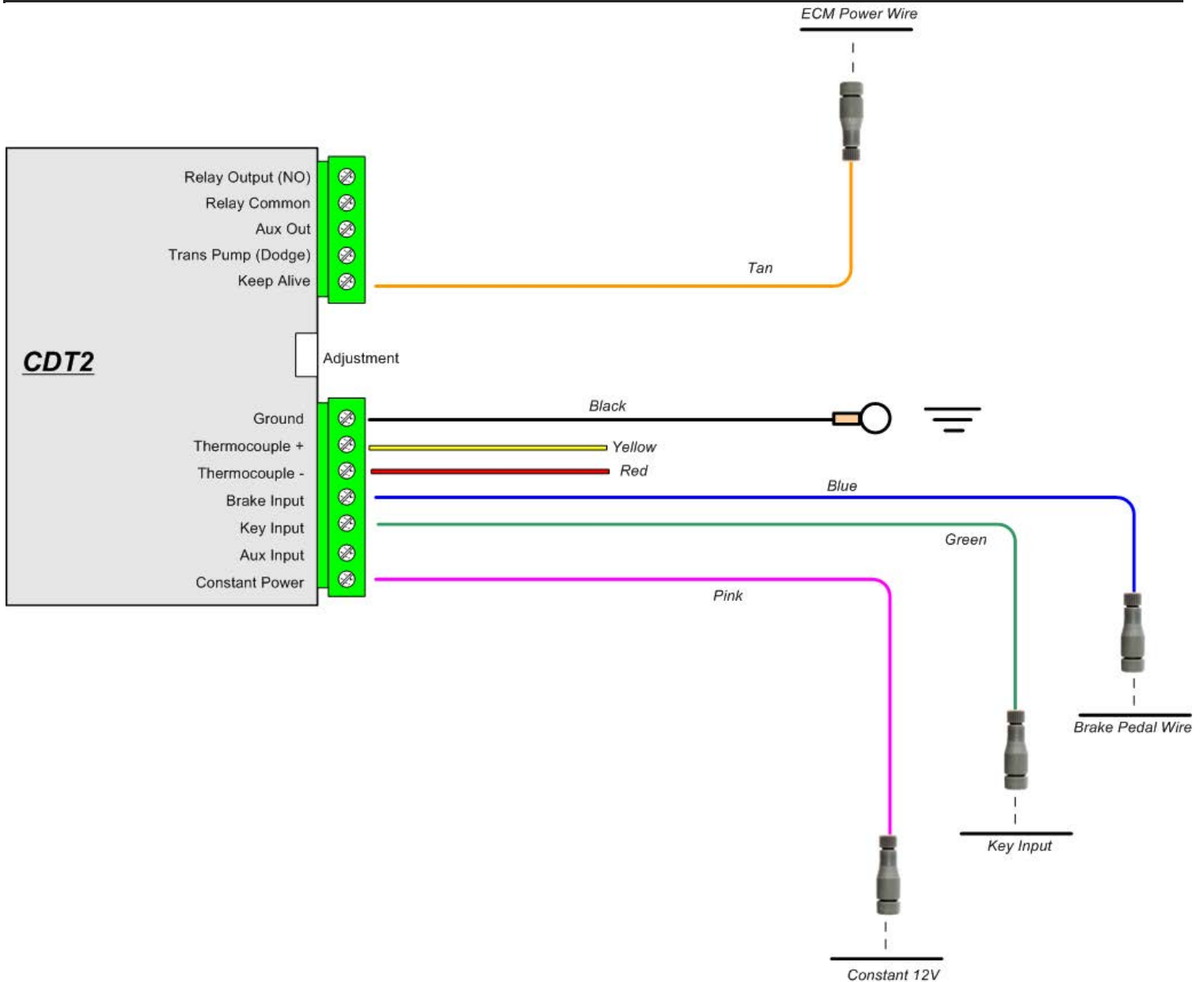

FORD POWERSTROKE WIRING DIAGRAM

Steering Column

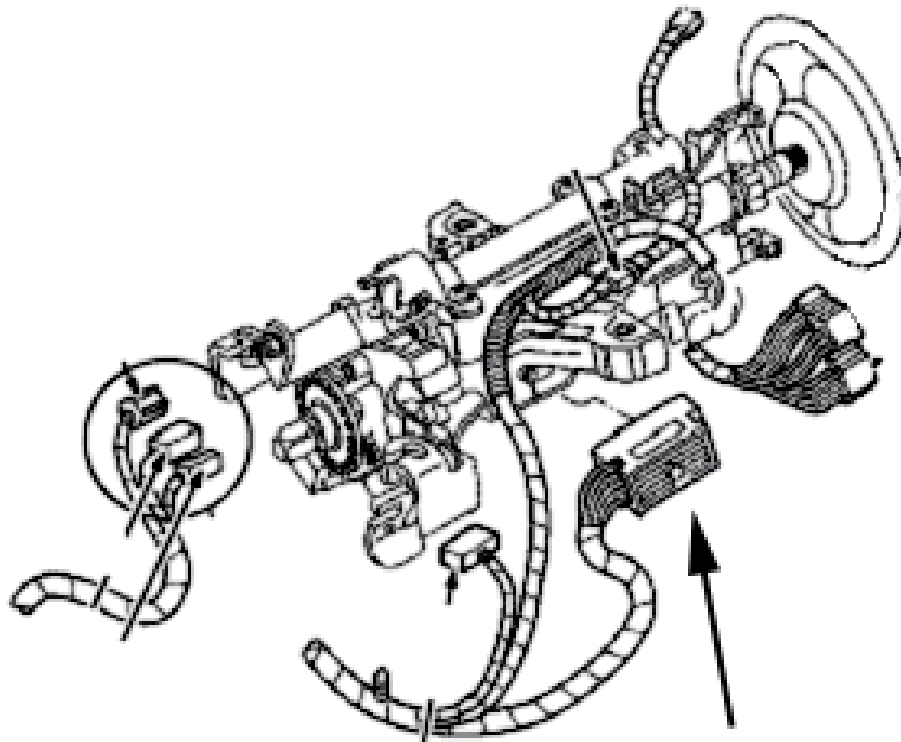

**Ignition Switch
(11572)**

1994-2004 Fords

2005-2007 Fords

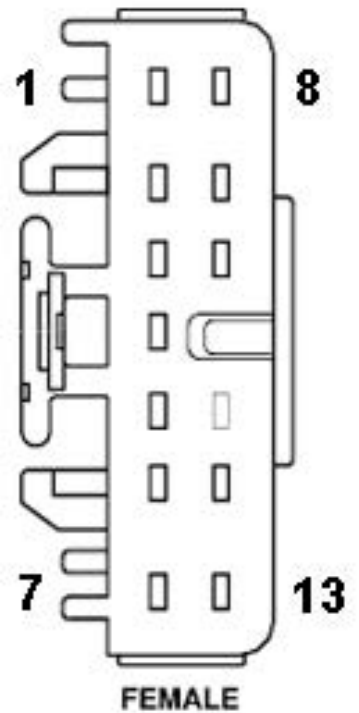
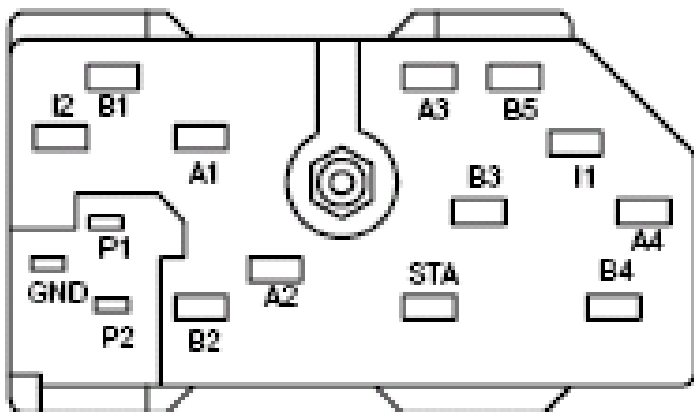

2008-2010 Fords

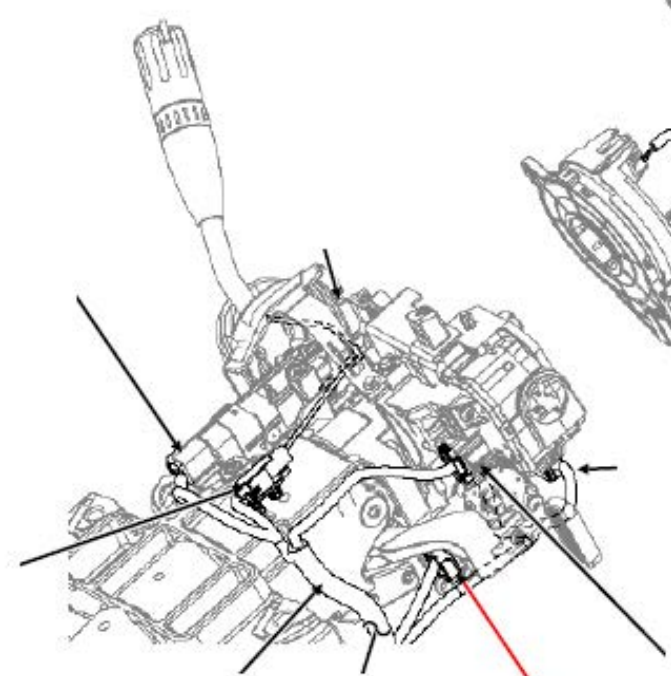
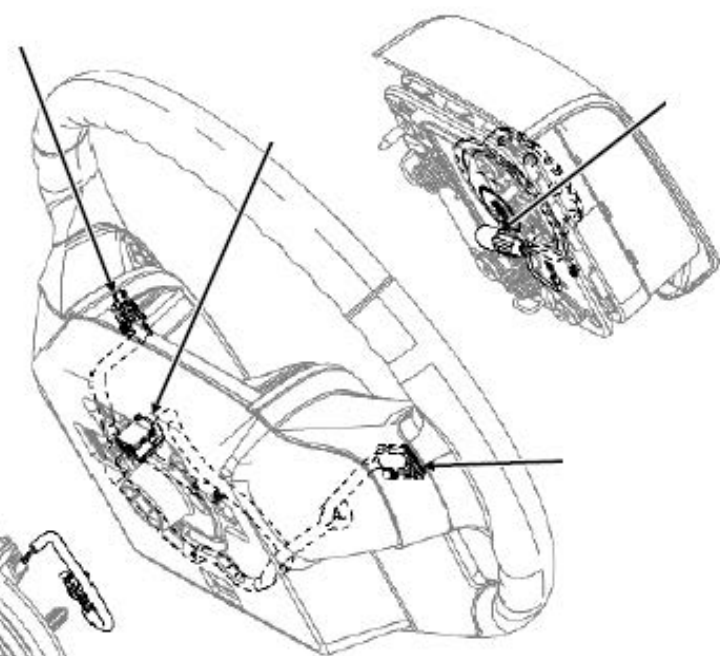
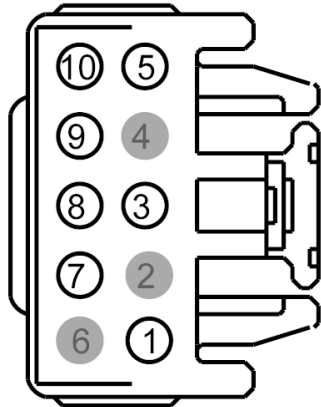

front of vehicle

**C250
Ignition
switch**

2011-2016 Connector location

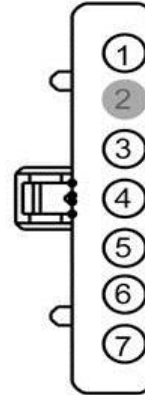

Connect the black wire to a good grounding point.

Model	Location	OEM Wire	Pin
Brake Pedal (Blue Wire)			
1994-2003 7.3L	Brake Pedal Switch	LG	4
2003-2007 6.0L		LG	03-05 (4) 06 (2) 07 (4)
2008-2010 6.4L		VT/WH	2
2011-2016 6.7L		VT/WH	4
Key (Green Wire)			
1994-1997 7.3L	Ignition Connector C269	BK/LG 297	A1
1999-2003 7.3L		RD/BK 1040	A3
2003-2004 6.0L	Ignition Connector C250	RD/BK 1040	A3
2005-2007 6.0L		RD/BK 1040	13
2008-2010 6.4L		BR/YE or YE/OG	7
2011-2016 6.7L		VT/GN	6
Keep Alive (Tan Wire)			
1994-1997 7.3L	Ignition Switch Harness	RD/LG 16	I1
1999-2001 7.3L		RD/BK 1000	I1
2002-2003 7.3L		RD/LG 16	I1
2003-2004 6.0L	Ignition Connector C250	WH/YL 1044	I1
2005-2007 6.0L		RD/LG 16	1
2008-2010 6.4L		WH/OG	1
2011-2016 6.7L		WH/OG	1
Constant (Pink Wire)			
1994-2003 7.3L	Ignition Switch Harness	YL 37	B1 or B3
2003-2004 6.0L	Ignition Connector C250	YL 37	B1 or B3
2005-2007 6.0L		YL 37	7
2007-2010 6.4L		DB/RD	8
2011-2016 6.7L		(Early 2011) BL/RD	4
		(2011.5 - 2016) GN/RD	

DODGE CUMMINS WIRING DIAGRAM

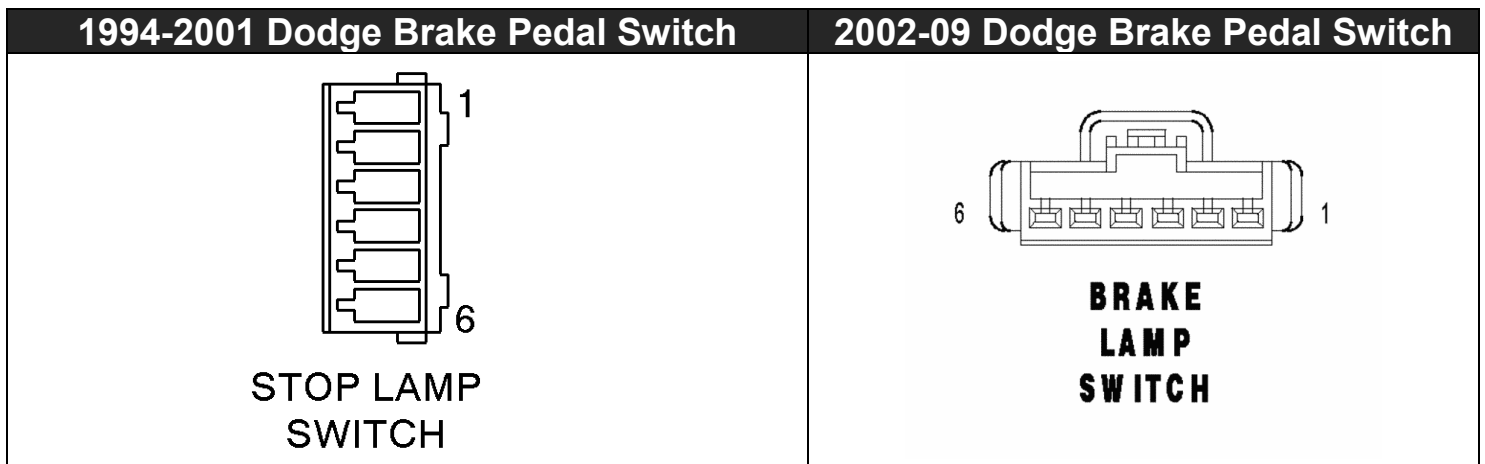
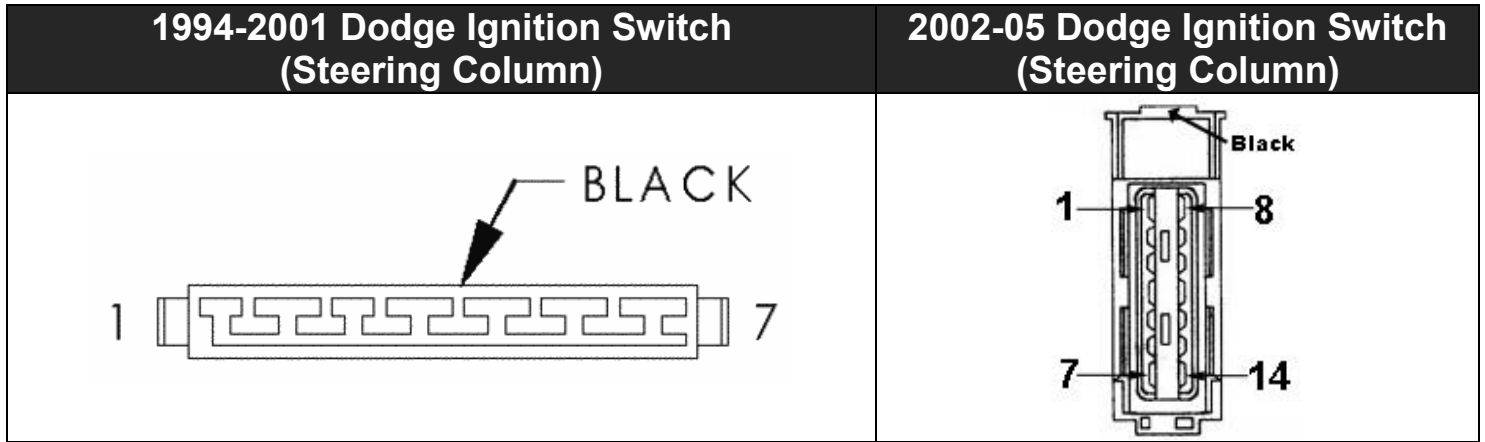

Model	Location	OEM Wire	Pin #
Brake Pedal (Blue Wire)			
1994-2001	Brake Pedal Switch	WT/TN L50	5
2002-2009		WT/TN L50	2
Key (Green Wire)			
1994-2002	Ignition Switch Harness	BK/OR A22	5
2003		BK/WT A31	9
2004-2005		PK/YL F982	9
Keep Alive (Tan Wire)			
1994-2002	Ignition Switch Harness	DB A21	2
2003		DB A21	3
2004-2005		PK/LG F951	3
Constant (Pink Wire)			
1994-2002	Ignition Switch Harness	RD A1	7
2003		RD A1	4
2004-2005		RD A951	4

2004½ - 2005 Dodge Trucks Wastegate Solenoid Power Wiring

Dodge trucks in the year 2004½ & 2005 have a waste gate solenoid that requires power when the CDT2 keeps the ECM alive in cool down mode. You may notice that the check engine light comes on (with codes P0480 & P0243) approximately 30 seconds after the key is turned off.

The codes being set do not affect performance or drivability in any way but only causes the annoyance of the engine light coming on. See the diagram below and on the next page for reference.

This step is ***not*** required for 2006 and newer Dodge trucks.

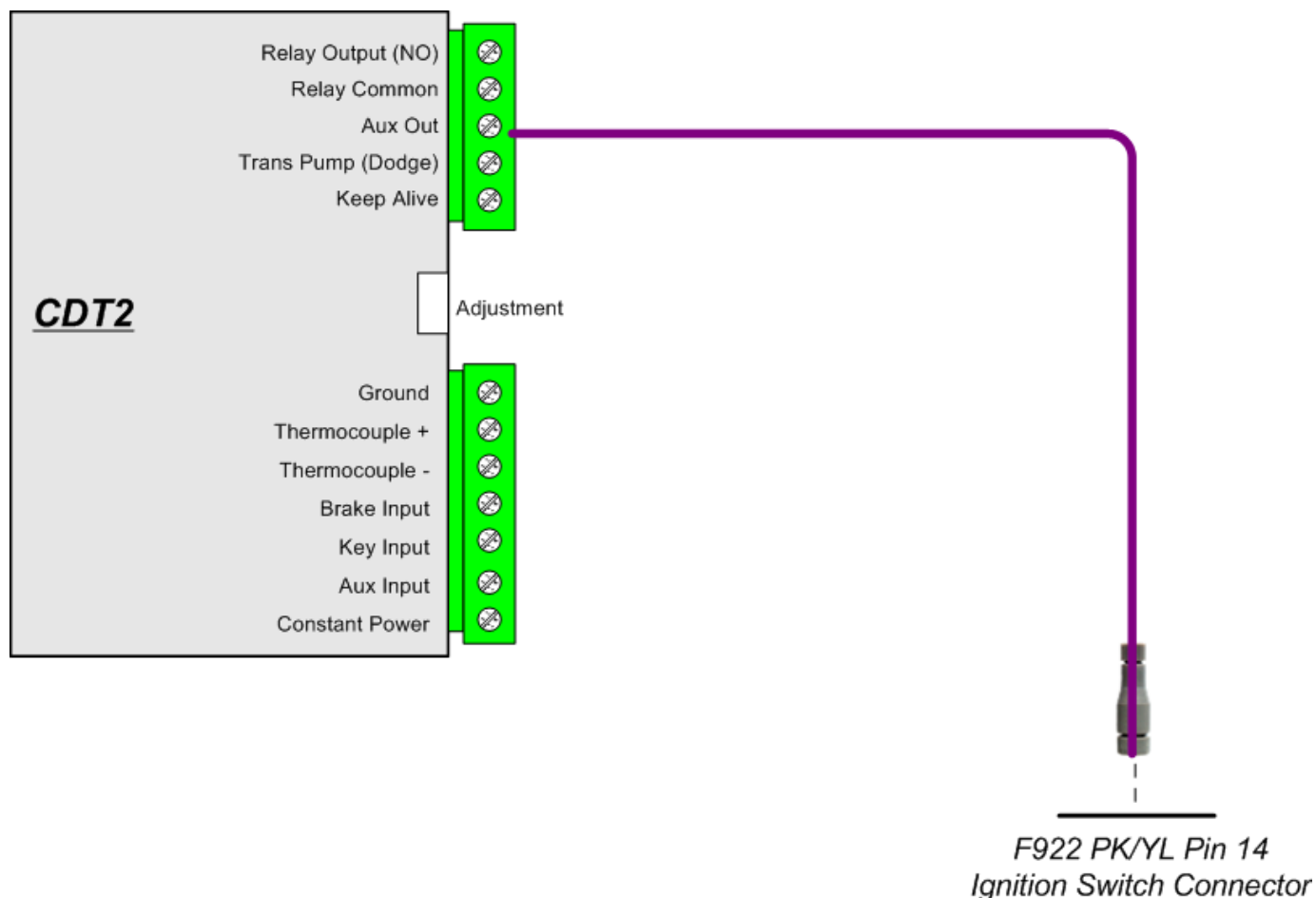

Dodge 2006-2009

1. Record radio settings and disconnect the negative terminal from both batteries.

2. Remove the knee bolster and upper and lower steering column covers.

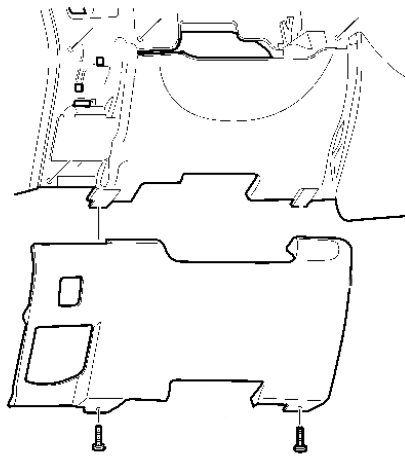

Knee Bolster

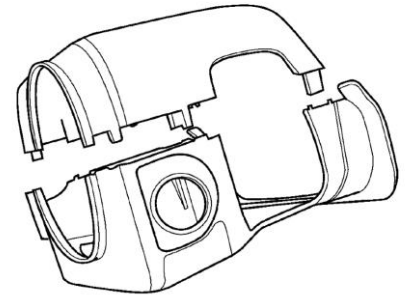

Steering Column Covers

3. Disconnect ignition switch connector. Then connect the CDT harness to the ignition switch connectors.

4. Connect blue brake switch wire to the WT/TN wire on the brake pedal switch.
(see table on page 13 above for details)

5. Secure module away from pedals. Route wires to module and connect using the general wiring diagram on page 9 in this manual.

6. Reinstall knee bolster and steering column covers.

7. Reconnect batteries and test for functionality.

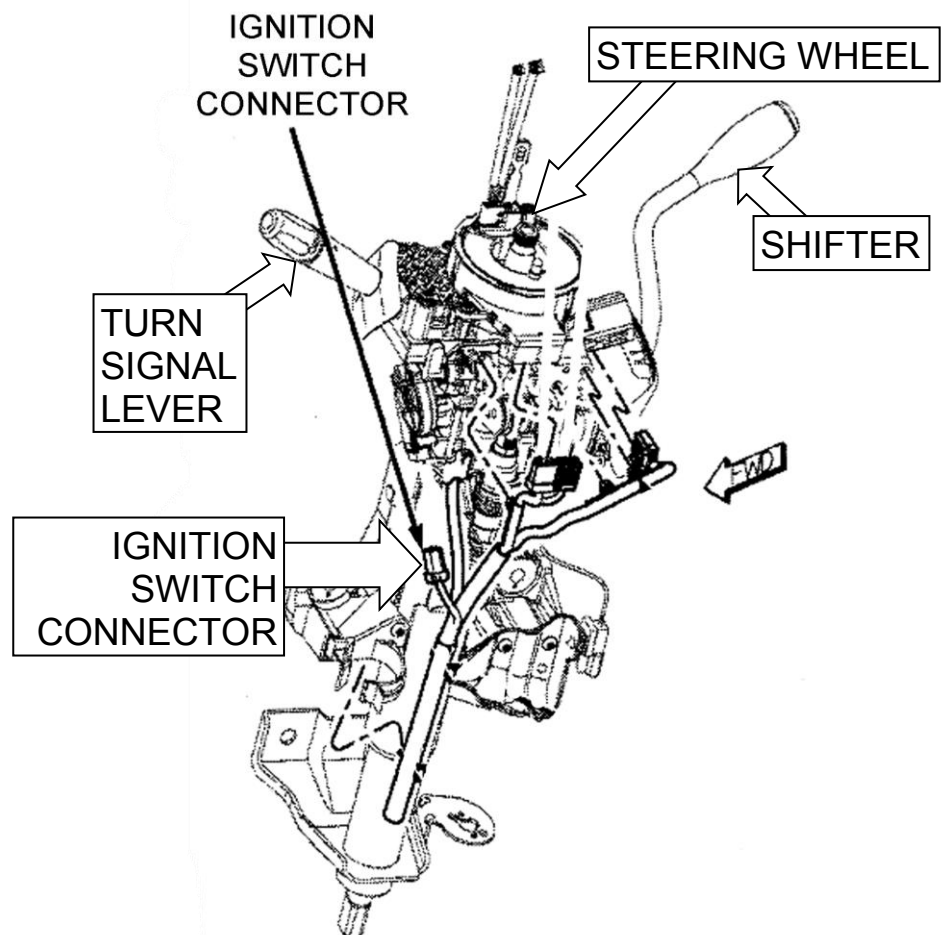

1. Record radio settings and disconnect the negative terminal from both batteries.

2. Remove knee bolster.

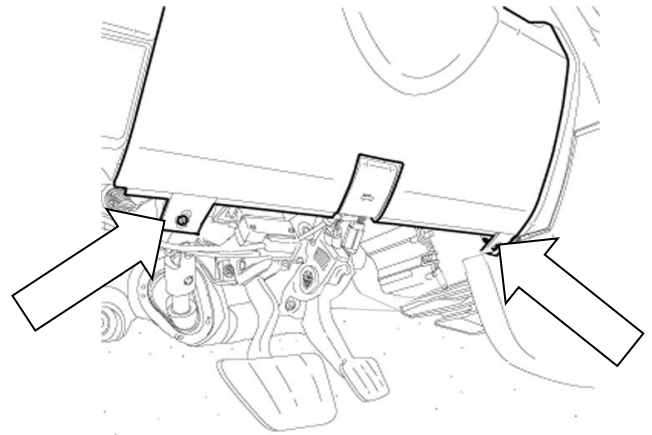

3. Disconnect ignition switch connector and plug CDT harness inline.

4. Mount module securely away from pedals. Route wires to module and connect wires using the general wiring diagram on page 9 in this manual.

5. Reinstall knee bolster.

6. Reconnect batteries and test for functionality.

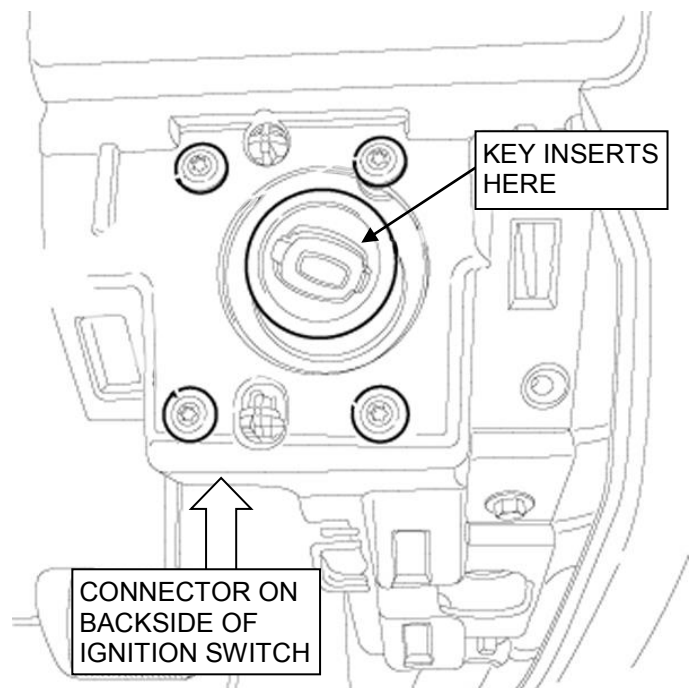

Dodge 2013-2016

1. Record radio settings. Disconnect batteries to avoid setting TPMS fault codes; also to avoid risk of short circuiting the 12V feed to the RF module.

2. Removal procedure for the 60/40 split rear seats is described in the following steps. Only the rear left (driver side) seat needs to be removed. Bench seat removal is similar but requires additional fastener removal.



3. Flip up the bottom of the left (driver side) rear seat. Disconnect the gray electrical connector for the seat and remove the two rear 18mm securing bolts



4. Flip up the under seat compartment lid by releasing the snap button. Remove the two forward 18mm securing bolts.



Lift rear left seat up to release it from the hooks on the rear cab wall and remove from vehicle.

5. Remove 13mm bolt from child seat tether. Remove push in fastener(s) from sound deadener panel. Pull panel back to expose "RF Hub" module.

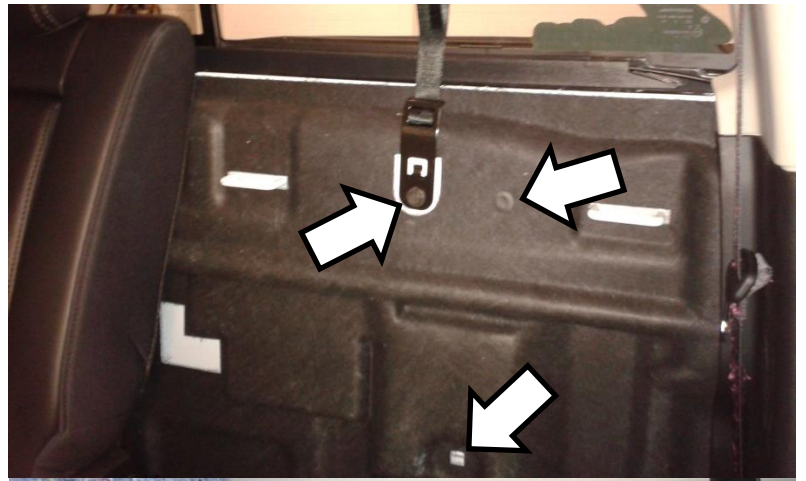

6. Disconnect upper driver side electrical connector from module and plug the BD CDT2 harness inline.

Note: On base models this is the only connector on the module. Vehicles equipped with the passive entry system have additional electrical connectors on the module.



7. Partially remove the lower pillar cover (black plastic) by pulling outwards to allow removal of the upper pillar cover.



8. Remove the Phillips screw securing the rear upper pillar cover and pull outwards to release.

Use care when removing the screw as it may drop inside the pillar.



9. Locate the white wire with green tracer at the gray connector at the top of the pillar; this is a brake light feed. Install the supplied posi-tap on this wire. Connect the posi-tap to the supplied length of light blue wire and secure to the OE harness away from seat belt components.

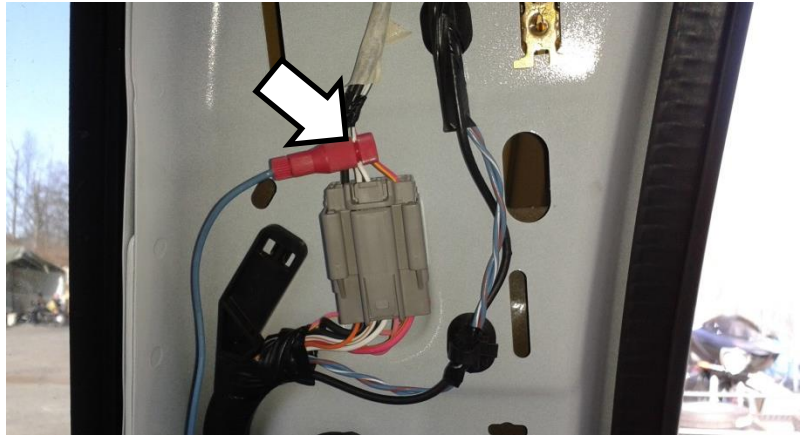

10. OPTIONAL: If utilizing the Cool Down Timer with a pyrometer probe, route the supplied red and yellow wires from the back of the cab to the location of the pyro wires either under the dash or in the engine bay. This wire should be routed under the door sills or under the carpet to the front and protected where necessary.
11. Install the black, pink, green, tan and blue wires into the module according to the wiring diagram at the front of the manual (page 9). Test module functionality before reassembly.

Depending on installer preference, the module may be mounted with the supplied velcro behind or below the seat such that it may be accessed for adjustments.

12. Reinstall seat and related components in the reverse order of disassembly.

DURAMAX WIRING DIAGRAMS

Duramax Ignition Connector Location

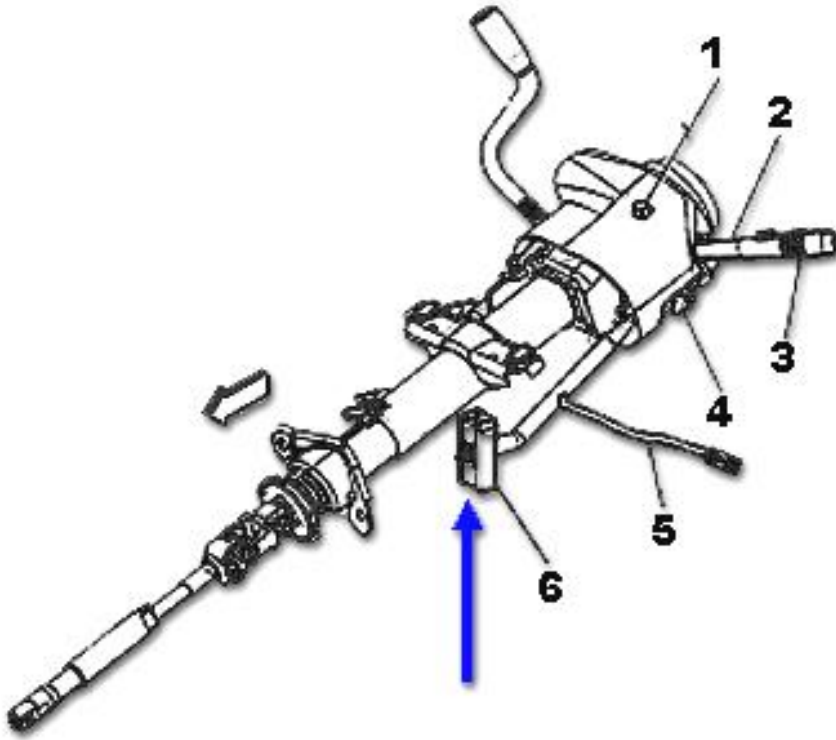

Legend

- 1. Hazard Button
- 2. Multi-Function Lever
- 3. Cruise Control Switches
- 4. Tilt Steering Actuator
- 5. Inflatable Restraint Harness
- 6. 201 Inline Connector

Connect the black wire to a good grounding point.

2001-2002 Duramax Ignition Connector (C201)

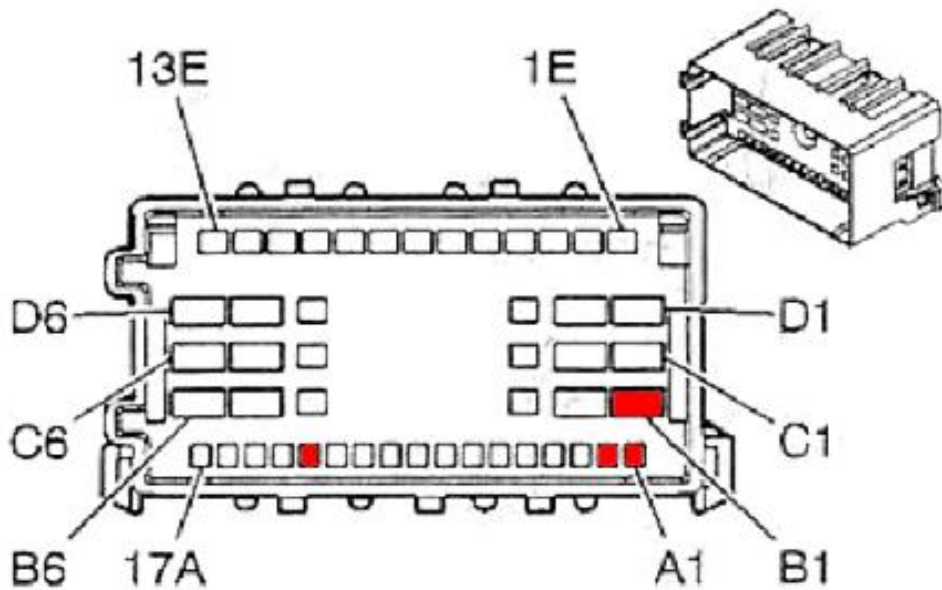

2003-2007 Duramax Ignition Connector

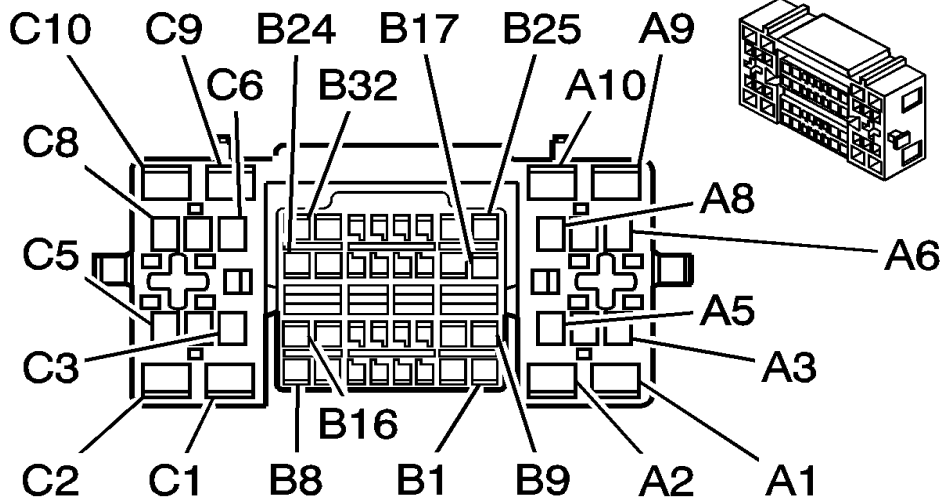

2007.5-2014 Duramax Body Control Module

Below the I/P

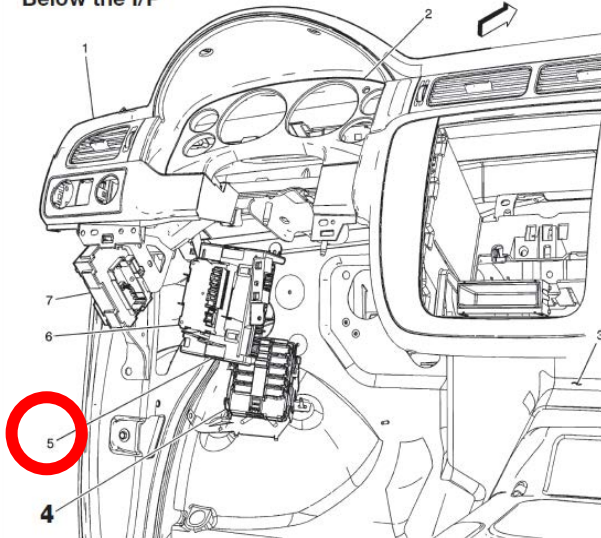

- (1) I/P Trim
- (2) I/P Cluster Trim
- (3) Floor Panel
- (4) Junction Block - Left I/P**
- (5) Body Control Module (BCM)
- (6) Transfer Case Shift Control Module
- (7) Fuse Block - I/P

1888353

Locate the BCM (#5).

Connector X1, Light Green in color. Face shown is internal mating face. You will need to access the reverse of this.

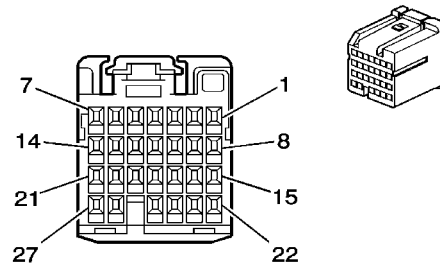

Connector X2, White in color. Face shown is internal mating face. You will need to access the reverse of this.

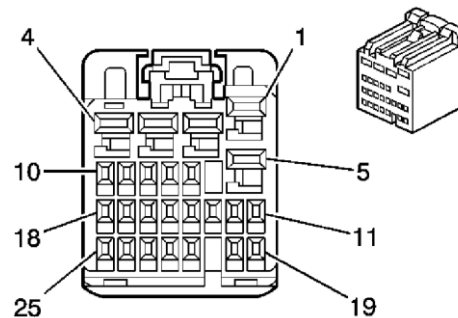

Connector X5 is Brown in color. Face shown is internal mating face. You will need to access the reverse of this.

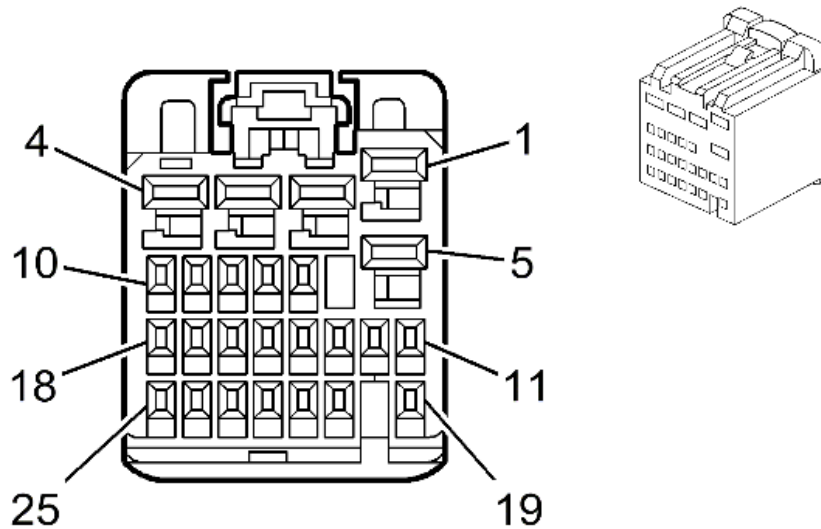

2003-2007 Duramax Brake Pedal Connector

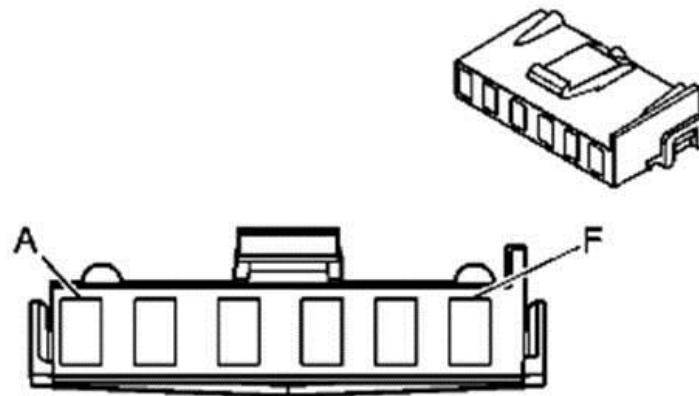

2007.5-2011 Duramax Brake Pedal Connector

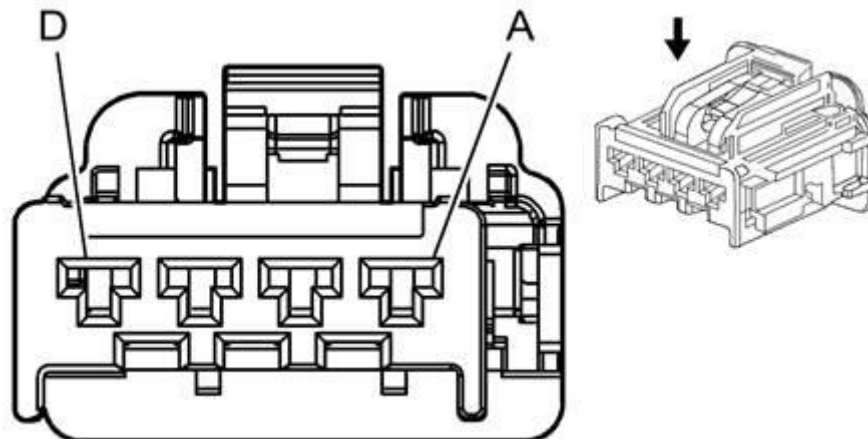

Model	Location	OEM Wire	Pin
Brake Pedal (Blue Wire)			
2001-2002	Ignition Connector C201	WT 17	A1
2003-2007	Brake Pedal Connector	WT 5689	2
2007.5-2011	Brake Pedal Connector	Light Blue/White	A
2012-2014	Body Control Module (BCM) X5	Light Blue/White	6
Key (Green Wire)			
2001-2002	Ignition Connector C201	BR 41	A13
2003-2007		BR 41	B18
2007.5-2010	Body Control Module (BCM) X1	PK 1020	2
2011-2014	Body Control Module (BCM) X1	Pink/Black	2
Keep Alive (Tan Wire)			
2001-2007	Ignition Connector C201	PK 139	A2
2007.5-2014	Body Control Module (BCM) X1	PK 3	14
Constant (Pink Wire)			
2001-2002	Ignition Connector C201	RD 242	B1
2003-2007		RD 342	C1
2007.5-2014	Body Control Module (BCM) X2	Red/White	2

Thermocouple Wiring (Not needed if monitoring with Time vs. Temp)

On most common “K” type thermocouples and wiring, a **yellow** wire is connected to the positive (+) side and a **red** wire is connected to the negative (-) side. The following are three common ways to connect the thermocouple to the CDT2 module. In all cases, the positive side of the thermocouple will be connected to the “Thermocouple +” terminal as indicated on the CDT2 module drawings and the negative side will be connected to the “Thermocouple -” terminal.

Direct Thermocouple Connection

If there is no pyrometer gauge in the vehicle and a thermocouple is being installed to connect to the CDT2 module, follow this diagram:

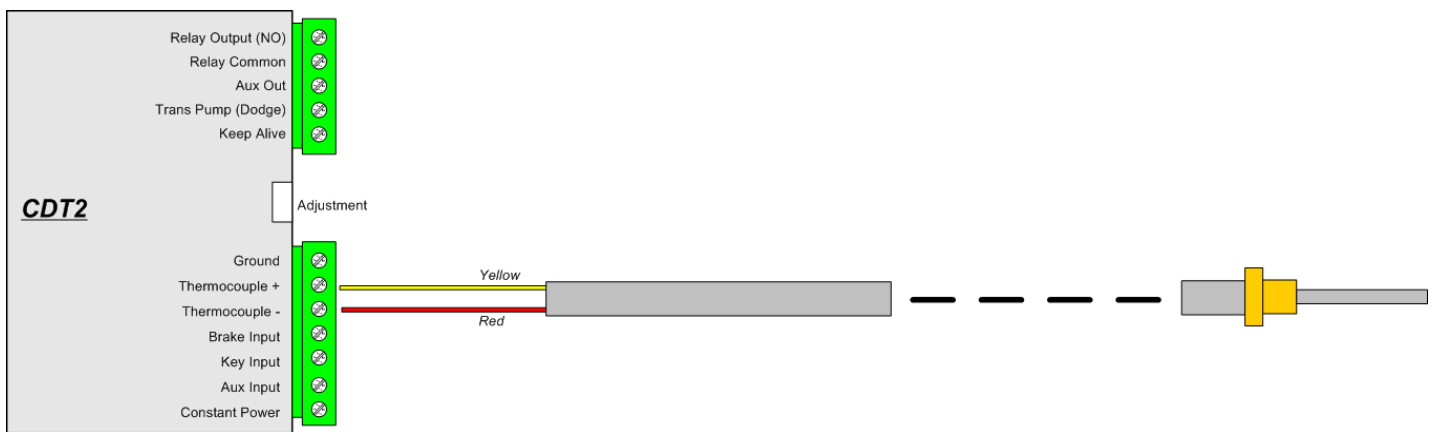

Amplified Pyrometer Gauge Kit

Some pyrometer gauge kits utilize a powered amplifier in between the pyrometer gauge head and the thermocouple. If the vehicle has one of these systems installed, use the following diagram:

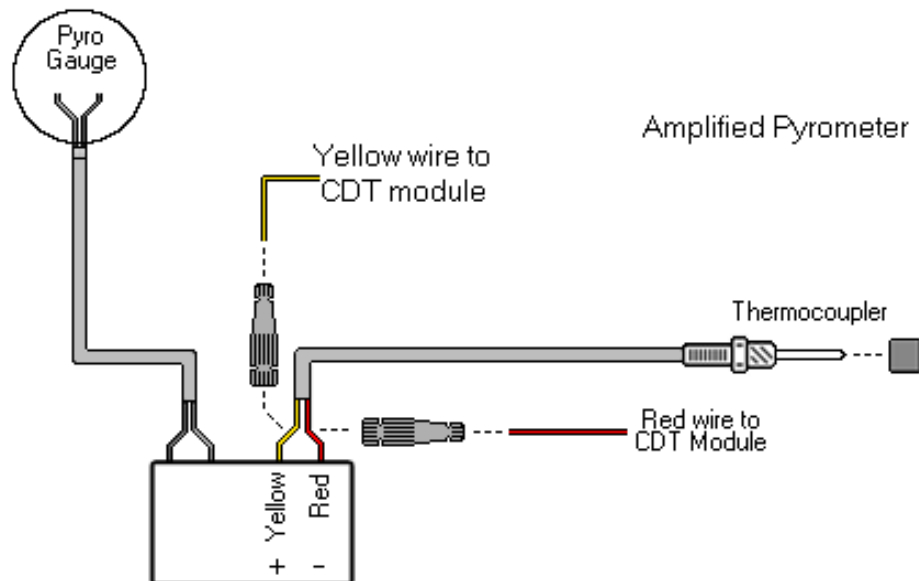

Conventional Non-Amplified Pyrometer Kit

A conventional pyrometer gauge kit will have the thermocouple connected to the pyrometer gauge head via a lead wire. If the vehicle has one of these systems installed, use the following diagram:

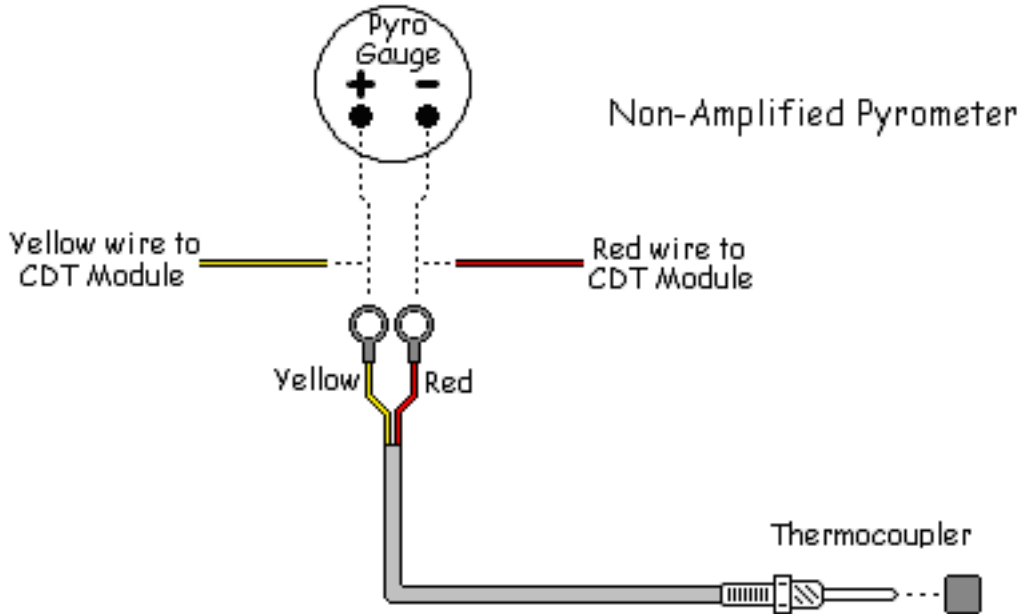

Temperature Adjustment

The shutdown temperature can be set by using a small flat-headed screwdriver to adjust the potentiometer that can be accessed through the hole on the left side of the CDT2 module.

By turning the screw all the way to the right (clockwise), the CDT2 will shutdown at approximately 550°F. By turning the potentiometer all the way counter-clockwise, the CDT2 will shutdown at approximately 250°F. The CDT2 may have to be adjusted a few times until the desired shutdown temperature is achieved.

NOTE: Be careful not to apply too much pressure as the potentiometer is plastic and can break.

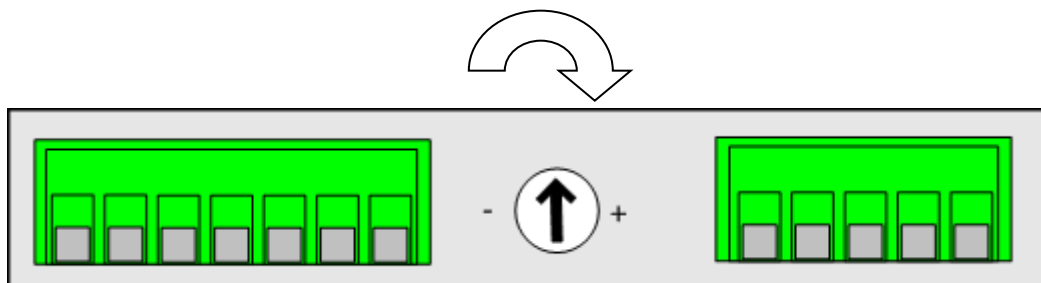

Adjustment Range: 250° to 550°

Time Adjustment

By default the CDT2 is setup to use the temperature as the default shutoff source. The unit can now be configured to use an adjustable time. If you unscrew the unit separating the two enclosure halves (the screw is located under the CDT2 sticker, in the middle of the module), you will see a jumper. You will need to set the jumper so that it connects pins **1 & 2**. See the diagram below for more information.

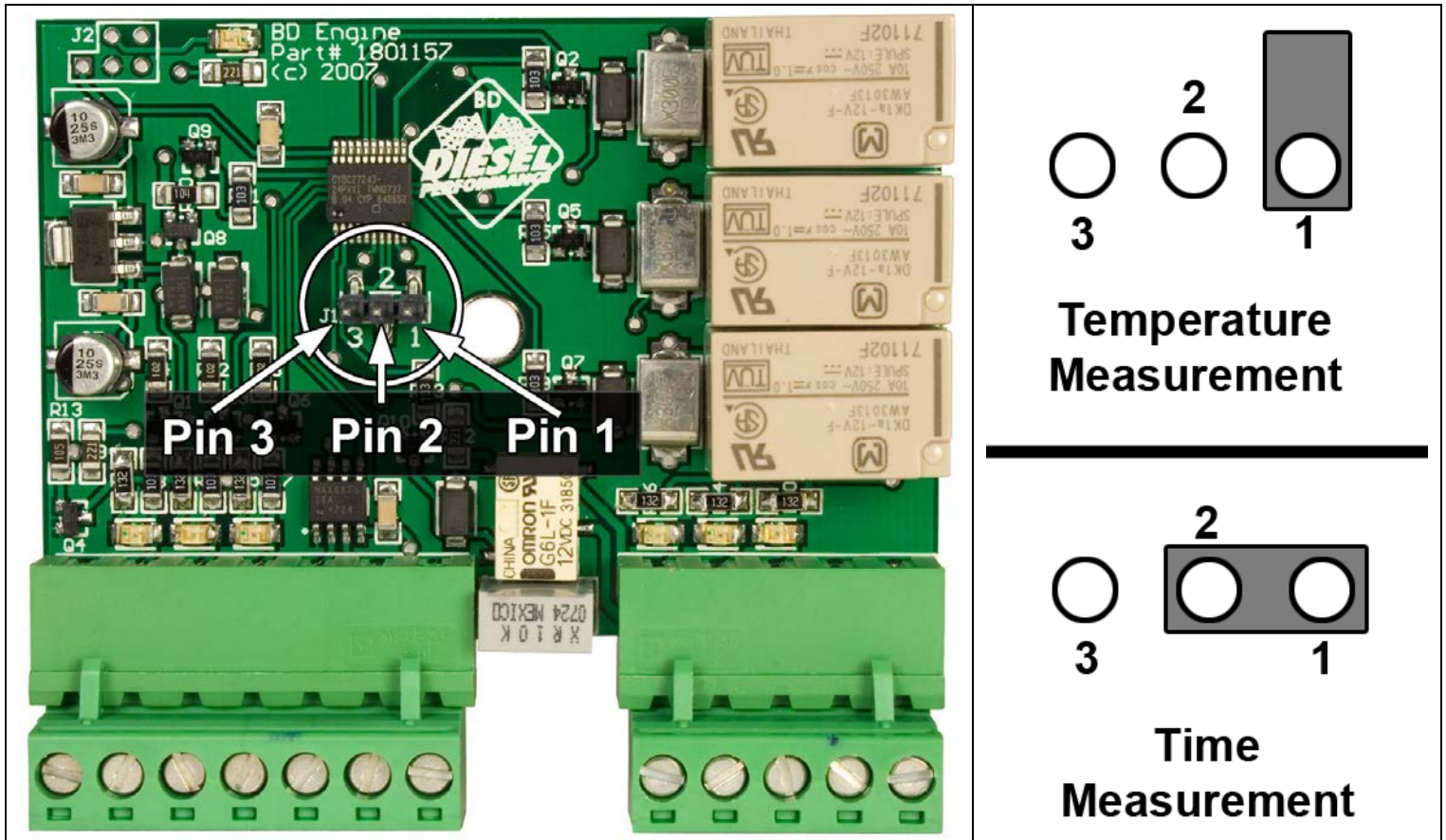

To adjust the time you can turn the potentiometer on the side of the unit.

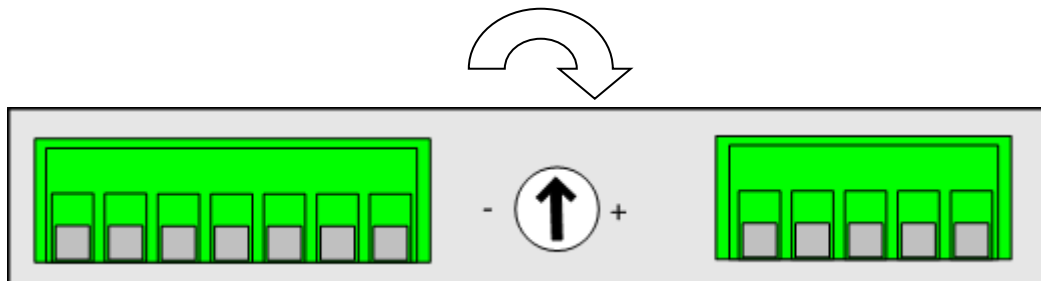

Adjustment Range: 60 to 300 seconds

Communication / Operation Lights

There are several built in LEDs within the CDT2 to help troubleshoot operation of the module, these are aligned with their corresponding input or output pin on the module.

Inputs		LED Operation
Key		Lit when supplied power
Aux. In		Lit when supplied power
Brake Input		Lit when Brake is depressed
Temperature		Lit when temperature is above set point
Outputs		LED Operation
Aux Out		Lit when output powered
Transfer Pump		Lit when output powered
Keep Alive		Lit when output powered

Mounting

Once all the wiring and adjustments have been performance, secure or mount the CDT2 module so that it does not interfere with pedal operation, the driver's feet, moving parts and is away from direct heat. The module may be mounted to an existing vehicle wiring harness using a zip-tie or may be adhered to the firewall using a double sided Velcro type tape.

Wire Color Glossary

BK	Black
BR	Brown
DB	Dark Blue
GN	Green
GY	Gray
LB	Light Blue
LG	Light Green
OR	Orange
PK	Pink
RD	Red
TN	Tan/Light Brown
WT	White
YL	Yellow

In the wiring diagrams, there are usually two wire colors for each OEM wire, for example: RD/LB. This means it's a red colored wire with a light blue tracer.

Troubleshooting

COMPLAINT: VEHICLE WON'T STAY RUNNING

