

## ***2001-04 LB7 GMC/Chevy Duramax Adjustable Waste Gate Kit***

**P/N# 1047160**

***This kit will not install on the 2004½ 6.6L LLY Duramax.***

***PLEASE READ ALL INSTRUCTIONS BEFORE INSTALLATION.  
Please read the disclaimer before proceeding to install this unit.***

***UNLESS AN EO# IS LISTED, THIS PRODUCT IS LEGAL IN CALIFORNIA FOR  
RACING VEHICLES ONLY, WHICH MAY NEVER BE USED UPON A HIGHWAY.***

## *Introduction*

The purpose of this kit is to allow the user to adjust the amount of boost pressure generated by their turbocharger. The larger diaphragm prevents waste gate creep and controls the waste gate much more efficiently.

*Do not exceed 32psi on the OEM turbo.*

## *Available Accessories*

- *BD SuperMax Turbocharger Kit*

## *Kit Contents*

<b>Part Number</b>	<b>Description</b>	<b>Qty.</b>
<b>1452257SSP</b>	LB7 Rod End w/ Actuator Pin	1
<b>1130141</b>	5/16" Nut	1
<b>1462446</b>	Lock Nut	2
<b>1453204</b>	Actuator	1
<b>1407153</b>	Clamp	2
<b>1407161-2</b>	Mounting Bracket	1
<b>1407155</b>	Silicone Hose	8"
<b>1130162</b>	Circlip	1

## Installation

Ensure that the engine coolant has dropped to ambient temperature before working on the vehicle.

Remove the plastic engine cowl or air intake silencer from the top of the engine; you should be able to access the factory wastegate at this point.

Remove the cir-clip from the wastegate arm. Remove the silicone hose from the wastegate actuator nipple.

Remove the top turbocharger coolant inlet hose fitting with a Torx #55 bit. Be sure to save the sealing washers and fitting as they will be re-used.

Apply air pressure to the wastegate diaphragm to stroke the rod. At this point you should be able to remove the rod from the wastegate arm.

Remove the two 12mm bolts securing the wastegate to the compressor housing.

Discard the stock wastegate.

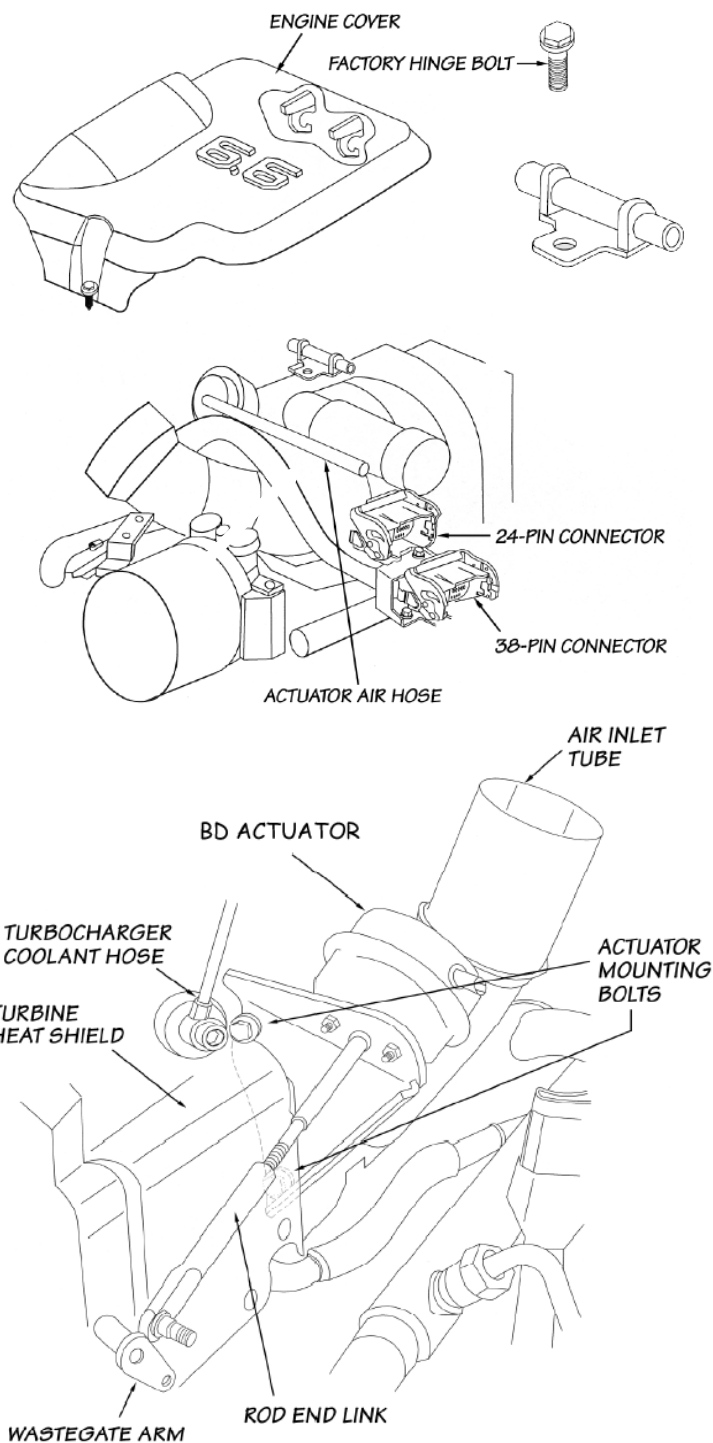

Using the two 12mm bolts, mount the BD actuator in place of the factory wastegate. Securely tighten the two bolts.

Apply air pressure to the wastegate diaphragm; this should stroke the rod end forward. Align the wastegate arm hole with the BD rod end and insert. Press the supplied circlip into place and secure the rod end to the wastegate rod.

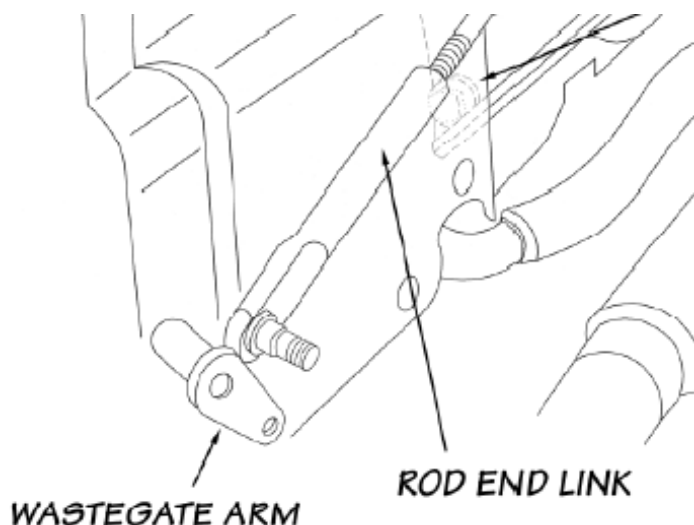

Install the supplied wastegate hose on the actuator nipple and on the factory compressor housing nipple. Secure the connection with the crimp style clamps.

Re-install the cooling line with the Torx bit and sealing washers.

Re-install the plastic engine shroud or intake silencer.

***The BD Actuator is pre-adjusted for ~27psi of boost pressure. Do not adjust the wastegate until you have test driven the truck.***

If you would like to adjust the wastegate, loosen the jam nut and slide the rod end off of the wastegate lever shaft. Turn the rod end in or out depending on how you want to adjust the boost pressure.

For more boost pressure, shorten the wastegate rod. For less boost pressure, lengthen the wastegate rod.

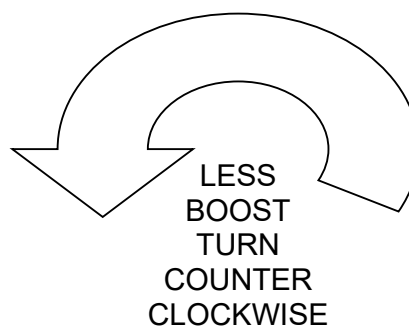
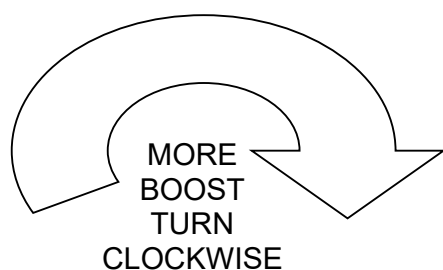

To increase the boost pressure, you will have sufficient energy to drive the turbo faster. Once you have turned the rod to the desired position, re-install the circlip and lock the jam nut.

**Do not exceed 32psi of boost pressure on the OEM turbo.**