



# **BD Duramax Screamer Turbo**

**Drop-in Turbo Replacement**

<b>Part #</b>	<b>Compressor Size</b>	<b>Model years</b>
<b>1045840</b>	<b>65 mm</b>	<b>2004.5-2010 Duramax LLY, LBZ, LMM</b>
<b>1045830</b>	<b>64 mm</b>	<b>2011-2016 Duramax LML</b>

LLY trucks require vane position adapter PN: 771864-0001.

## PRE-INSTALLATION

A new turbocharger will not solve the following failures:

- Oil contamination
- Restrictive oil drain
- Over speed due to a boost leak
- Exhaust leaks due to faulty bellows, clamps, or seals

Turbo over speed will lead to premature turbo failure. Boost pressure can be used to estimate turbo speed. The table below shows maximum allowable turbo speed for a stock motor at 3500rpm. A turbo intake restriction, clogged filter, high altitude or boost leak will cause increased wheel speed.

Turbo	Estimated Airflow (lb/min)	Max Wheel speed (rpm)	Max boost (psi)	Max Boost with clogged filter (psi)
LLY, LBZ, LMM	85	121,000	40	37
LML	80	121,000	39	36

## Kit Contents

1045830



Turbo; Screamer 2011-16 LML

Qty: 1

**1045840**

Turbo; Screamer 2004.5-2010 LLY, LBZ, LMM

**Qty: 1*****Introduction***

The BD Screamer turbo series is now available for the 2004.5-2016 Duramax. The Screamer turbo is designed to be a drop-in stock-appearing performance turbocharger that increases the total airflow without affecting low-end drivability.

BD's Duramax screamer line-up utilizes a custom mixed flow turbine (MFT) wheel with a large 65mm exducer. In the GT37 VNT, a MFT wheel geometry offers increased efficiency in both initial spool up and high flow operation. At high flow operation, the increased efficiency of the MFT wheel allows the variable nozzle technology to open up and act like a larger turbine housing, which reduces drive pressure and lowers the required exhaust gas temperatures. During turbocharger spool up, the vanes close, creating high velocity "jets" used to spool the turbocharger. The geometry of the MFT more efficiently harnesses these high velocity jets, allowing the use of a larger compressor wheel without compromising on drivability.

***Installation***

The 2004.5-2010 Duramax Screamer turbo fits all LLY, LBZ, and LMM engine codes. The LLY engines will require the vane positions sensor adapter, part number 771864-0001.

Please follow GM's factory replacement instructions for detailed year specific turbocharger replacement procedure.

1. Install the oil return pipe using a new gasket.

Torque to 21 Nm (15 lb ft)

2. Install the turbocharger outlet coolant pipe banjo bolt and washers.

Torque to 26 NM (19 lb ft)

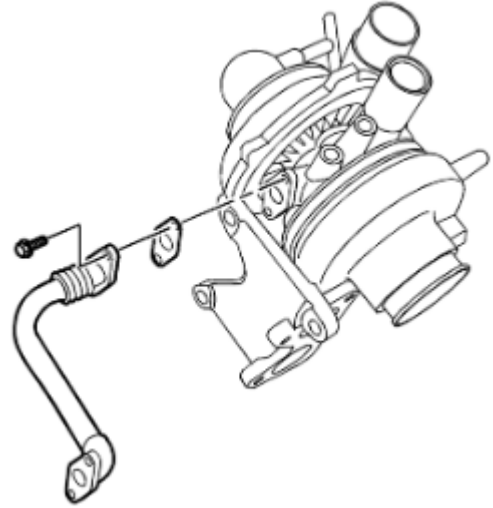

3. Install the oil feed pipe, washer, and bolt.

Do not twist the oil feed pipe.

Torque to 34 NM (25 lb ft)

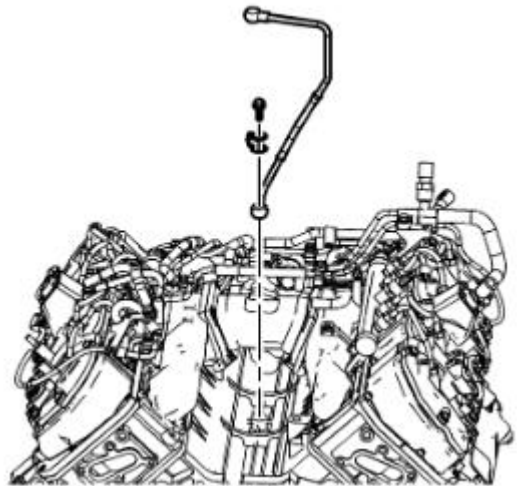

4. Install the turbocharger lower heat shield.

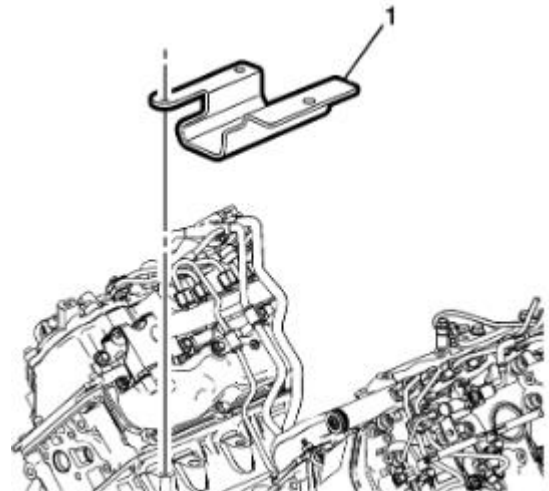

5. Install the turbocharger with the oil return pipe.

Torque the turbocharger mounting bolts to 78 Nm (58 lb ft)

6. Install the oil return pipe nuts at the top of the flywheel housing. Torque to 25 Nm (18 lb ft).

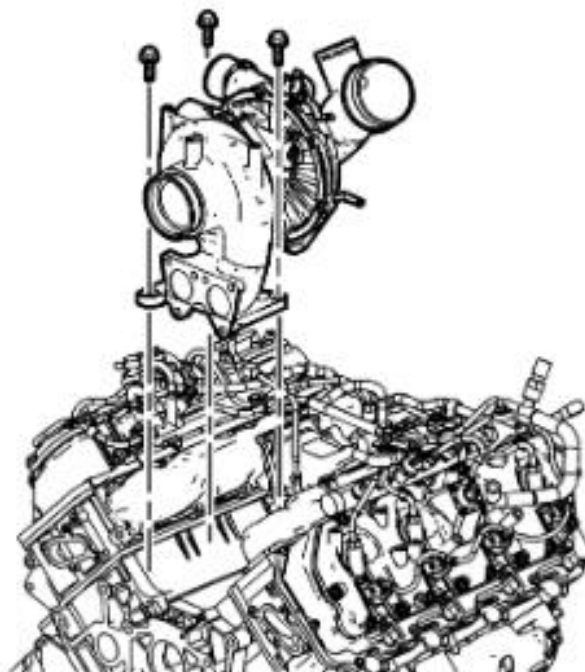

7. Connect the vane position sensor connector.

8. Pre-lube and add 120-150cc of clean engine oil in the turbocharger oil feed pipe while rotating the impeller.

9. Install the oil feed pipe, washer, and banjo bolt. Torque to 34 Nm (25 lb ft)

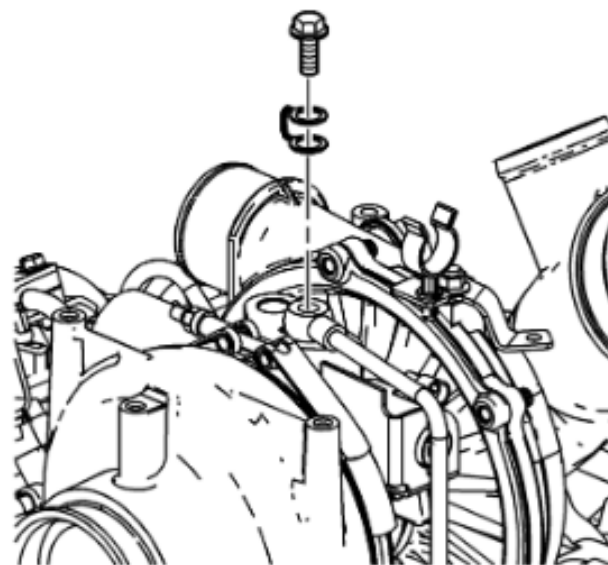

10. Install PCV hose/pipe.

11. Install the cooling outlet hose eye bolt and any remaining coolant hoses.

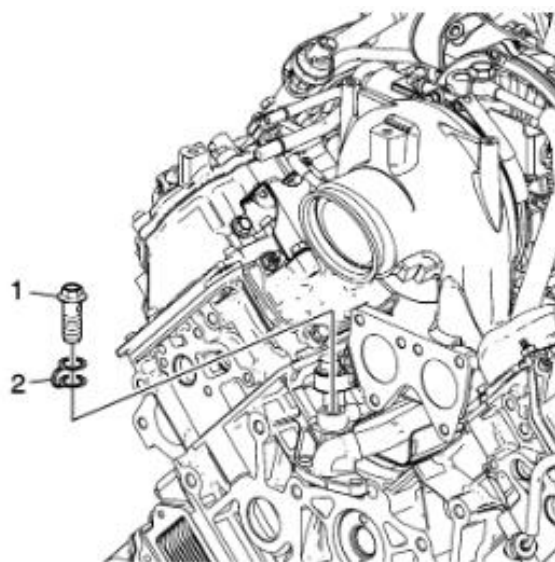

12. Install the turbocharger heat shield and bolts. Torque to 9 Nm (7 lb ft)

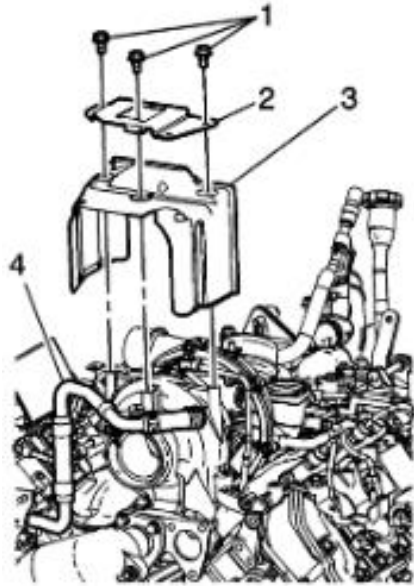

13. Install the exhaust manifold outlet pipes.

Tighten in the sequence shown.

Torque the manifold bolts to 53 Nm (39 lb ft)

Torque the turbocharger bolts to 25 Nm (18 lb ft)

Torque the EGR bolts to 25 Nm (18 lb ft)

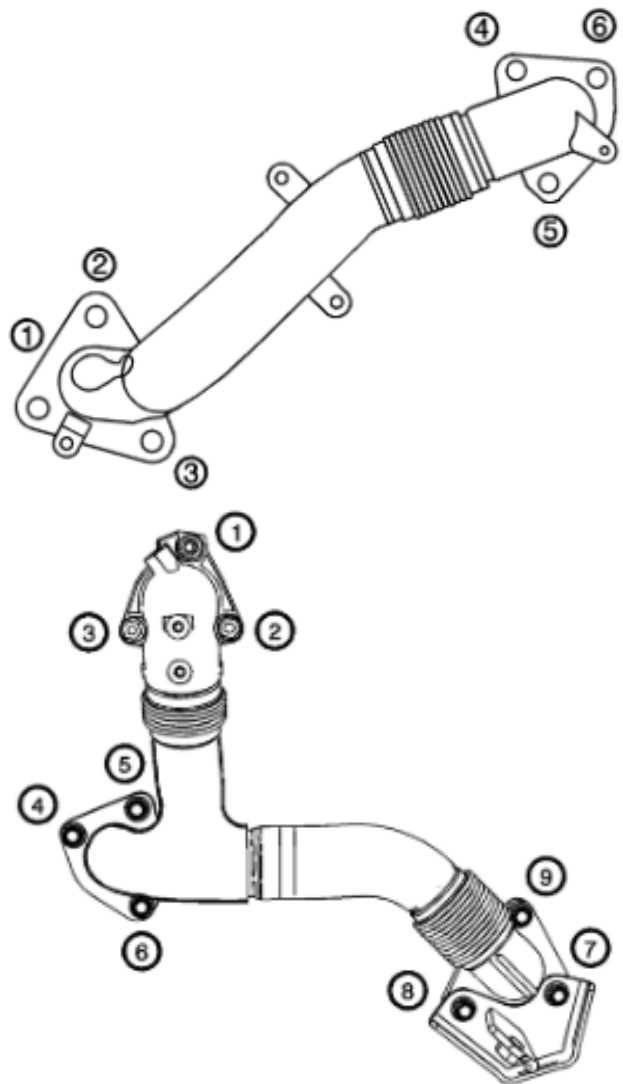

14. Reinstall the EGR cooler.
15. Reinstall the glow plug module and both brackets.
16. Install the EGR cooler pipe bolt. Torque to 9 Nm (6.6 lb ft)

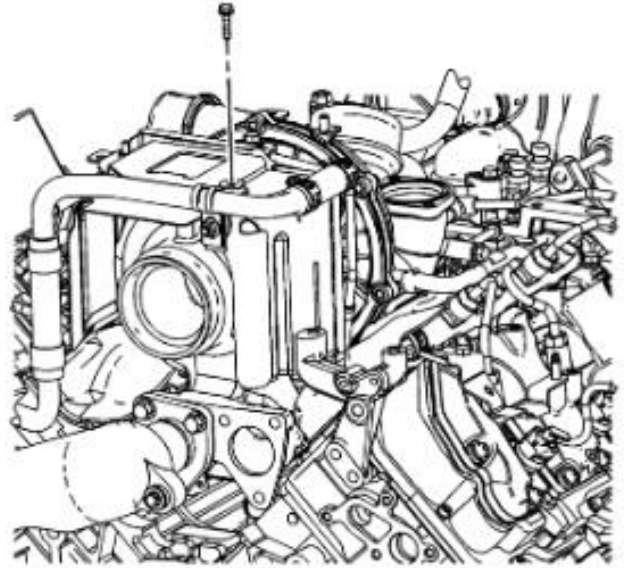

17. Install the charge air cooler inlet pipe.
18. Install the turbocharger air intake pipe.
19. Install the exhaust downpipe. Tighten clamp to 40 Nm (30 lb ft)

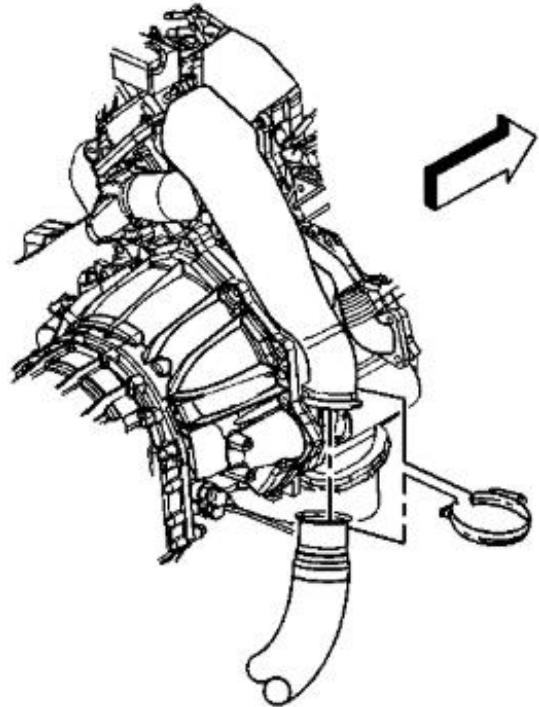

19. Perform the turbocharger learn procedure.

## ***Turbocharger Learn Procedure***

The engine control module performs the turbocharger learn procedure automatically when the engine coolant temperature is at least 72°C (162°F). After each ignition cycle, and before the enable criteria have been met, the ECM will use the previously learned value. If the ECM does not have a previously learn value, it will default to a stored calibrated value. The ECM will use this value until the enable criteria have been met. It will then perform this procedure to learn the new value. If the ECM attempts to perform the turbocharger learn procedure and fails, DTCs P003A or P2563 may set.

If a TC learn is not performed after a related turbocharger repair, the ECM will use a stored vane position value that may be invalid. The ECM may then cause a diagnostic to fail and set an invalid DTC. Certain enable criteria must be met for the ECM to perform this procedure.

The turbocharger learn procedure is required when the following service procedures have been performed.

- TC vane position control solenoid valve replacement
- TC vane position sensor replacement
- ECM replacement
- TC replacement
- Any service that disrupts the TC components