



BD Diesel Ford Exhaust Manifold

6.7L Power Stroke F250-550

1043006	2011-2016 Drivers Side Manifold + Studs/ Spacer kit
1043007*	2011-2014 Exhaust Manifold Pair + Stud/ Spacer kit





*Replaces the early style manifold that comes with the GT32 turbo & crossover pipe (Pickup + Cab & Chassis). 2015+ trucks that use the GT37 turbo utilize a different manifold.

Includes longer exhaust studs, spacers and locking nuts.
Gaskets are included.

Kit Contents

1043006 (2011-2018 Drivers Side Manifold + Studs/Spacer)





1403006	1403009	FT-11141221
		
Manifold; Drivers Side 11-18 Qty: 1	Spacer; Ford 6.7 Manifold Qty: 16	Nut; M8x1.25 Lock Flange Qty: 19

FT-11559036	1462432	FC3Z-9448-A	BC3Z-6N640-A	1130055
				
Stud; M8x1.25x35 Qty: 3	Stud; M8x1.25x50 Qty: 16	Gasket; Exhaust Manifold Qty: 1	Gasket; Cross Over Pipe Qty: 1	Nut; M8x1.25 Qty: 2

1043007 (2011-2014 Exhaust Manifold Pair + Studs/Spacer)

1403006	1403007
	
Manifold; Drivers Side 11-18 Qty: 1	Manifold; Passenger Side 11-14 Qty: 1

HC3Z-9E464-A	1403009	FT-11141221
		
Gasket; Manifold to EGR Qty: 1	Spacer; Ford 6.7 Manifold Qty: 16	Nut; M8x1.25 Lock Flange Qty: 22

FT-11559036	1462432	FC3Z-9448-A	BC3Z-6N640-A	1130055
				
Stud; M8x1.25x35	Stud; M8x1.25x50	Gasket; Exhaust Manifold	Gasket; Cross Over Pipe	Nut; M8x1.25
Qty: 6	Qty: 16	Qty: 2	Qty: 2	Qty: 2

Introduction

The BD performance exhaust manifold has 75% thicker than OEM walls and is machined with a thicker bolting flange to improve service life at high temperatures.

The thicker bolting flange can be used with OEM studs and spacers, but it is recommended to use the included longer studs and spacers.

Installation/ Torque Specifications

Remove all OEM studs from the head and clean all surfaces prior to installation.

Be sure to keep debris from falling into the exhaust runners and potentially causing engine damage.

Use the two included nuts to fully thread in and torque all M8 studs. Use the two-nut method as shown.

Install and torque new M8x1.25x50 studs (1462432) to into the head.

Thread the shorter end into the head.

Torque to 9.5 ftlbs (115 inlbs) dry.

If penetrating fluid is present in the thread, reduce the torque specification by 40% (9.5ftlbs dry = 5.7ftlbs lubricated).

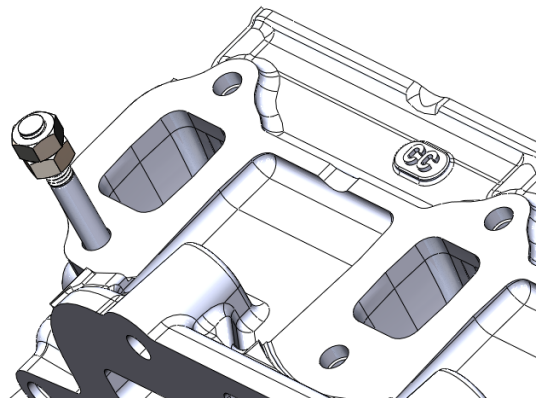

Install and torque new M8x1.25x35 studs (FT-11559036) into the end of the manifold.

Torque to 9.5 ftlbs (115 inlbs) dry.

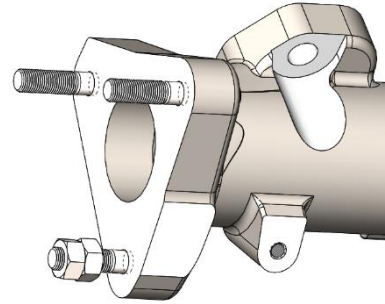

Install the manifold gasket (FC3Z-9448-A) and longer BD spacers (1403009) and locking flange nuts (FT-11508940). Torque the manifold using the following sequence:

Do not lubricate the threads.

Stage 1: 13 ftlbs (159 inlbs) dry.

Stage 2: 18 ftlbs (216 inlbs) dry.

Stage 3: Repeat 18 ftlbs (216 inlbs) dry.

IMPORTANT:

Do not over-torque the stud. Between stage 1 and stage 3 torque steps the nut should not rotate more than 90 degrees. If the stud has started to yield, the stud and nut must be replaced.

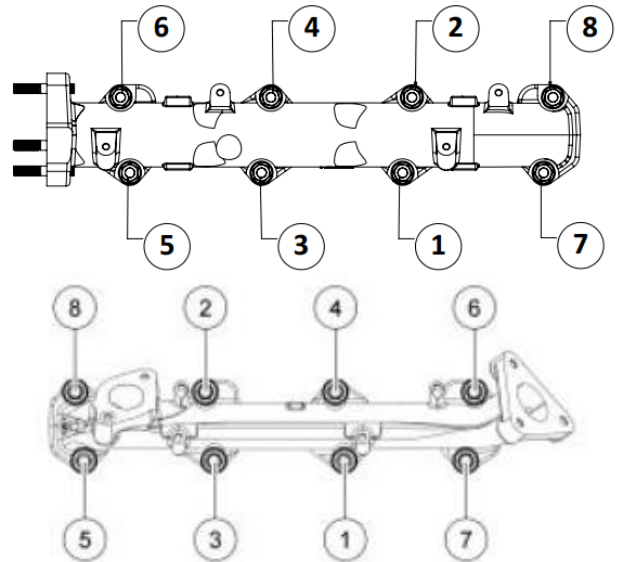

Install both heat shields.

Tighten to 7.4 ftlbs (89 inlbs)

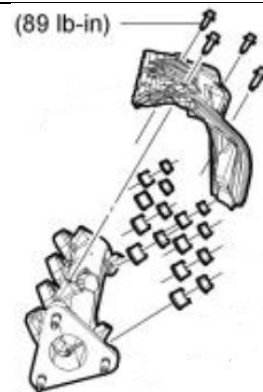

Install the turbocharger and tighten the fastening bolts in the following sequence:

Stage 1: 11 ftlbs

Stage 2: 41 ftlbs



Install the cross over pipe gasket (BC3Z-6N640-A) and cross over pipe using the supplied flange lock nuts (FT-11508940).

Torque nuts to 18 ftlbs (216 inlbs)

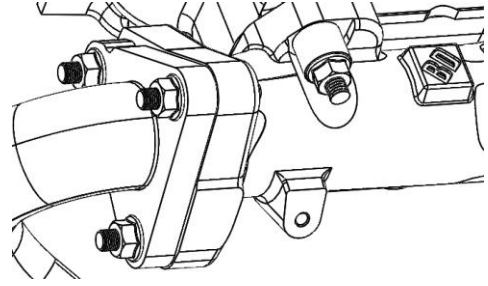

Install the manifold to EGR gasket (HC3Z-9E464-A) to the EGR tube.

Tighten to 89 inlbs

