

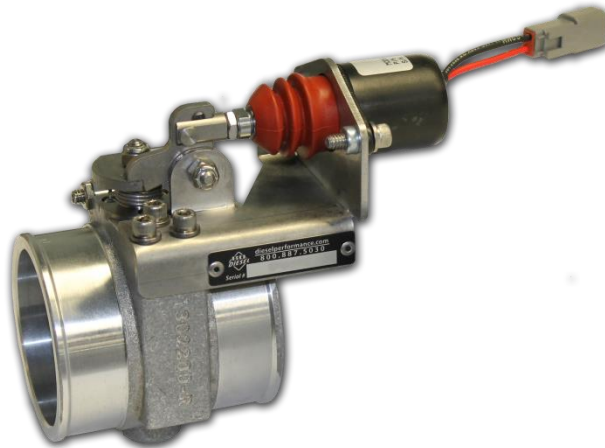

INSTALL MANUAL



2013/17 6.7 Dodge Cummins Positive Air Shutoff

P/N#	1036724
------	---------

P/N#	1036724-M
------	-----------











PLEASE READ ALL INSTRUCTIONS BEFORE INSTALLATION

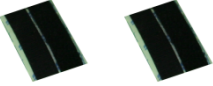

An Information decal has been provided in this kit. This may allow safety personal and inspector's to quickly identify that your vehicle is equipped with a BD Positive Air Shut Down unit. Install this decal in a visible location on the inside glass of the vehicle.

KIT CONTENTS:

Please check to make sure that you have all the parts listed in this kit **before** you start the disassembly of your truck.

1036724 Kit Contents			
1302300-A	1302275-A	1302278	
			
<i>Air Shutoff Valve</i>	<i>Wiring Harness</i>	<i>PAS Pipe</i>	
Qty: 1	Qty: 1	Qty: 1	
1405211	1407030	1405212	
			
<i>0325 Clamp</i>	<i>0350 Clamp</i>	<i>0356 Clamp</i>	
Qty: 3	Qty: 2	Qty: 1	
1800060	1301381	1306720	1302285
			
<i>Velcro strips</i>	<i>Heat Shrink</i>	<i>6.7 Electronic Module</i>	<i>Solder</i>
Qty: 1	Qty: 1	Qty: 1	Qty: 1
1405404	1302425	1302424	
			
<i>3"-3 1/4" Silicone Boot</i>	<i>3 1/4"-3 1/2" Step Boot</i>	<i>2 3/4" Step Boot</i>	
Qty: 1	Qty: 1	Qty: 1	

1036724-M Kit Contents		
1302300-A	1302249-A	1302278
		
<i>Air Shutoff Valve</i> Qty: 1	<i>Wiring Harness</i> Qty: 1	<i>PAS Pipe</i> Qty: 1
1302424	1302425	1405404
		
<i>2 3/4" Silicone Boot</i> Qty: 1	<i>3 1/4"-3 1/2" Step Boot</i> Qty: 1	<i>3"-3 1/4" Step Boot</i> Qty: 1
1405211	1407030	1405212
		
<i>0325 Clamp</i> Qty: 3	<i>0350 Clamps</i> Qty: 2	<i>0356 Clamp</i> Qty: 1

WELCOME

Thank you for purchasing a BD positive air shutoff. This manual is divided into different areas to assist you with your installation and operation of your positive Air shutoff. This product is a safety product and should be tested often. Installation should occur on a vehicle properly secured to prevent rolling.

TABLE OF CONTENTS

1036724 Kit Contents	2
1036724-M Kit Contents	3
REQUIRED TOOLS.....	4
MAINTENANCE.....	4
INSTALLATION with OVER SPEED ELECTRONICS (1036724).....	5
INSTALLATION without OVER SPEED ELECTRONICS (1036724-M).....	10
WIRING DIAGRAM with OVER SPEED ELECTRONICS (1036724)	15
WIRING DIAGRAM without OVER SPEED ELECTRONICS (1036724-M)	16
RESETTING THE VALVE.....	17
SETUP, TESTING AND VERIFICATION with OVER SPEED ELECTRONICS.....	18
Automatic Mode (Pre Configured RPM)	18
Manual Mode (User Configured RPM)	20
TESTING FLOW CHART with OVER SPEED ELECTRONICS	23
TESTING FLOW CHART without OVER SPEED ELECTRONICS	24
LED OPERATION.....	25

REQUIRED TOOLS

- Frequency/Voltmeter (Optional)
- Drill
- 1/8" Drill Bit
- 11/32" Drill Bit
- Needle Nose Pliers
- 1/2" Unibit
- Electrical Tape
- Reciprocating saw
- Soldering Iron
- Air or Manual Ratchet
- 7/16", 1/2" Sockets
- Wire Strippers
- Heat Gun
- Center Punch
- Band Saw/ Cutoff Wheel

MAINTENANCE

No maintenance is needed other than check to make sure the valve is acting correctly. Please see the testing section later in the manual for the correct procedure.

INSTALLATION with OVER SPEED ELECTRONICS (1036724)**VEHICLE SHOULD BE SAFELY SECURED BEFORE INSTALLATION.**

1. Block the wheels of the vehicle to prevent the vehicle from rolling and open the hood.
2. Remove the plastic inner fender then disconnect / remove the driver side charge air cooler (CAC) pipe using a 7/16" socket and ratchet to loosen clamps.



Note: Leave all clamps loose to allow movement.

3. Connect the 1302424 boot onto the supplied pipe using a 1405211 clamp.

Then connect the 1302425 & 1405404 boots onto the PAS valve using the 1407030 clamps.

With both assemblies completed, install the pipe assembly onto the CAC using the other 1405211 clamp.

Then install the valve assembly onto the intake using the 1405212 clamp.

Finally rotate and connect the two assemblies until aligned, then tighten all clamps till springs are bound. (1/2" socket)

Reinstall plastic inner fender.

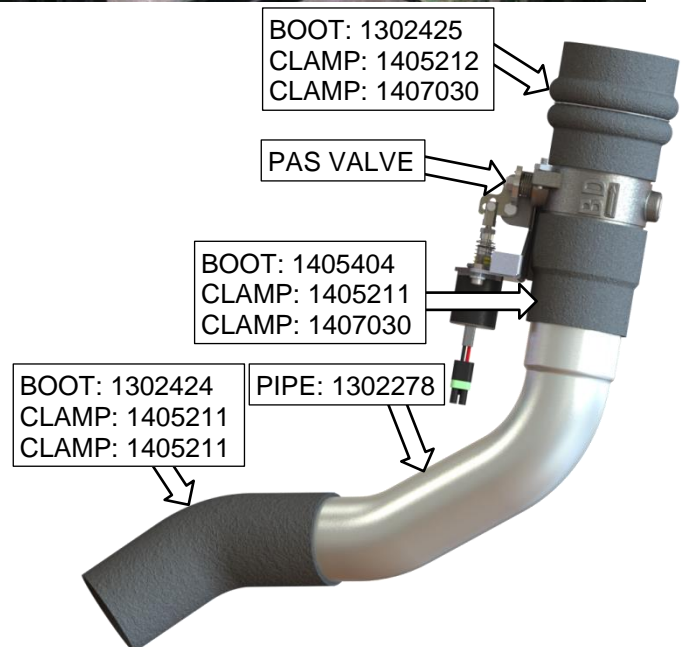
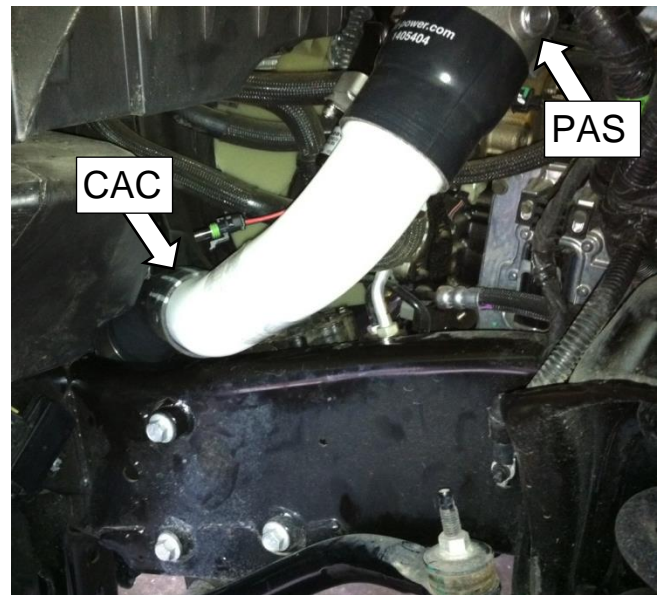

4. Once the PAS assembly is in place lay out the supplied harness over top of the driver's side of the engine.

You will then need to route the switch wires through the firewall (note you will need to remove the switch from the harness to accomplish this). See wiring diagram on page 14

Choose a highly visible location for the switch and mount it to the dash.

Using a 1/8" drill, drill a pilot hole in the location you have selected for the switch to be mounted.

Finally using a 1/2" UNIBIT drill bit, drill an exact 1/2" round hole.

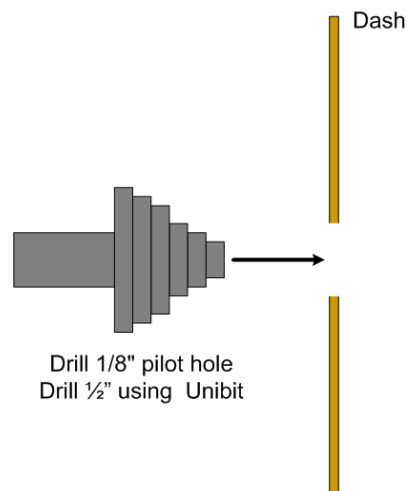

5. Once you have the mounting hole drilled, insert the switch from the backside.

Reinstall the correct wires to the correct switch terminals.

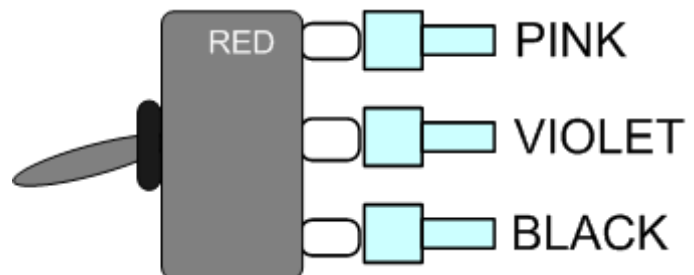

6. Mount the switch so that the groove on thread boss is facing down.

Adjust the HEX washer/nut so that the switch threads do not protrude an unsightly amount.

Switch install with decal

Apply the supplied decal to the dash and tighten the round plastic nut.

Switch install with Guard

Install the switch guard onto the switch by aligning the tab with the groove on the thread boss.

Then tighten on the round plastic nut and apply the decal to the switch guard.

Switch install with Decal

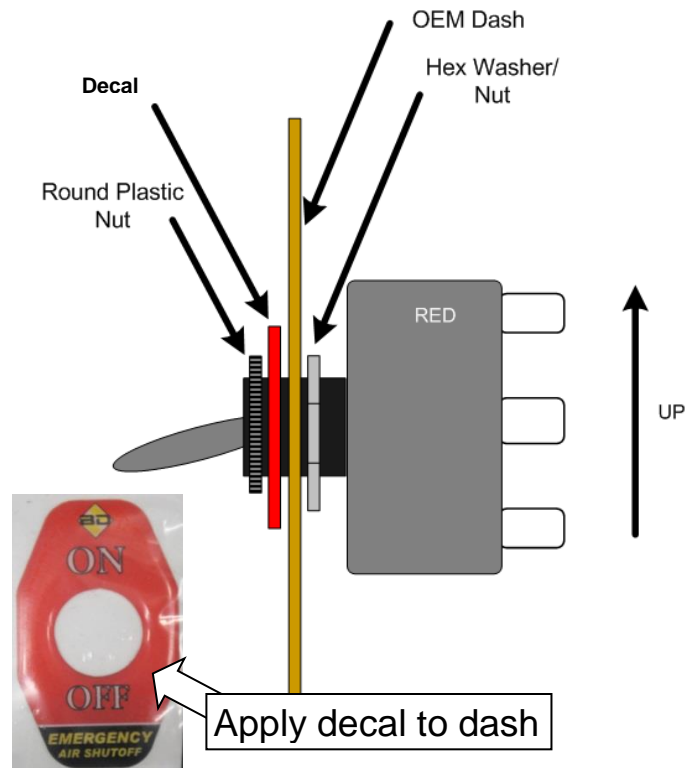

Switch Install with Guard

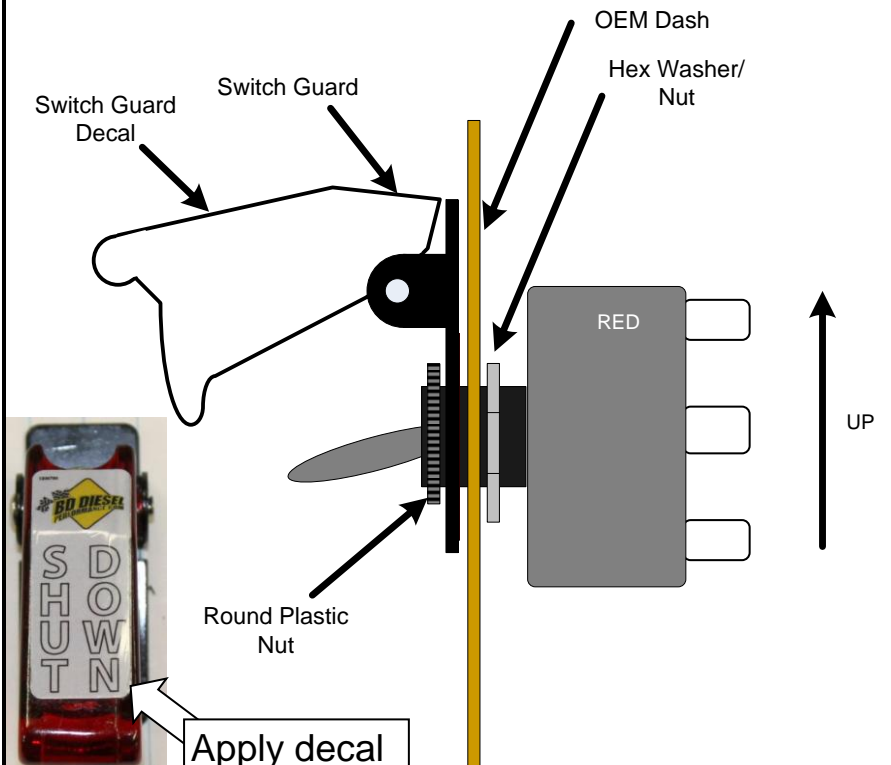

7. Locate and connect the weather pack connector on the wiring harness to the solenoid on the PAS valve.

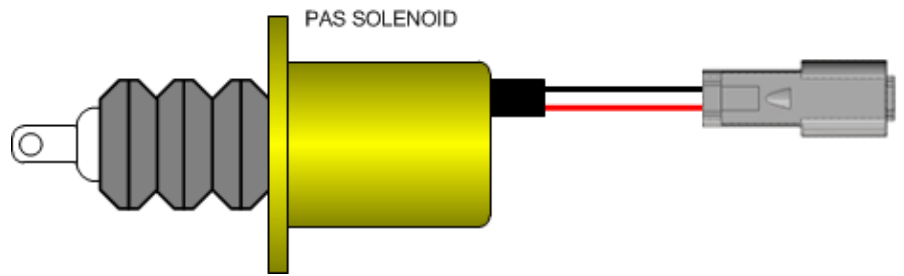

8. Connect the crank signal wire close to the sensor, located on the driver's side of the crank pulley.

BROWN WITH LIGHT BLUE TRACER

Being that the RPM signal is critical you will need to solder the connection.

Using wire strippers create a 1" window/gap in insulation of the wire.

Then strip about 1" of insulation from the BLUE RPM signal wire in the PAS wiring harness.

Wrap stripped end of the blue wire around the factory RPM signal wire and solder this connection.

Then use electrical tape to wrap this connection so that it is water tight.

You can also cut the factory crank signal wire and use heat shrink tubing if you like.

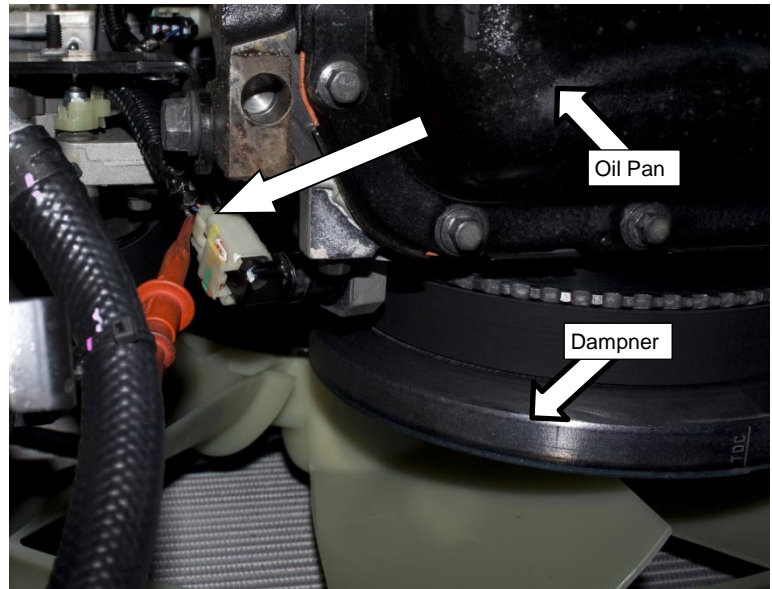
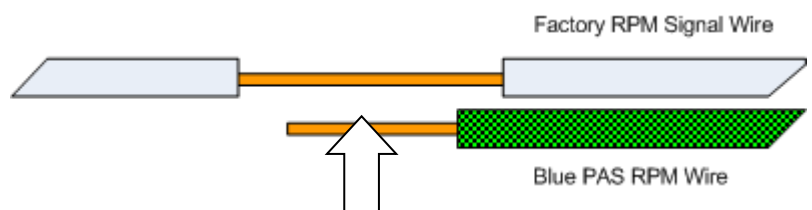
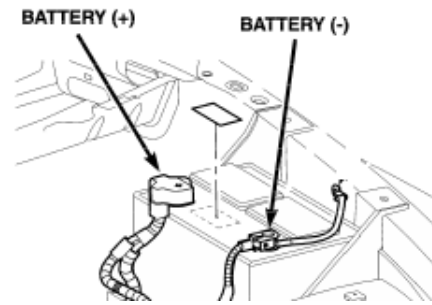

Image is from the underside of the truck



Solder the connection and then wrap and seal with electrical tape

9. Next on the wiring harness, connect the BLACK and RED wires to the respective battery connections. (Driver's Side Battery).



10. For the last connection you will need to locate ignition power. This will power the automatic over speed control box LED switch. Note the unit can still be activated manually with the switch at any time. Locate the fuse panel in front of the driver's side battery. Remove the cover. Locate appropriate fused ignition power circuit. Connect yellow wire with flag connector to this new connection. Route wire out of fuse box and close lid.



11. With the fuse box closed, mount the control module on top of it using the supplied Velcro.

Be sure to clean both surfaces with rubbing alcohol before applying the velcro.

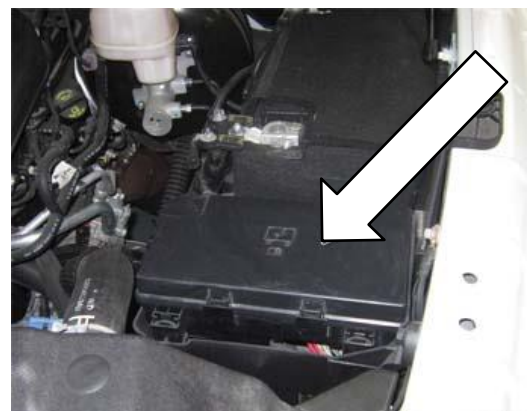

12. Double check all wiring connections and ensure wires are routed away from any heat sources and moving parts. Proceed to the "Setup, Testing and Verification *with* Over Speed" section on page 18.

INSTALLATION without OVER SPEED ELECTRONICS (1036724-M)**VEHICLE SHOULD BE SAFELY SECURED BEFORE INSTALLATION.**

1. Block the wheels of the vehicle to prevent the vehicle from rolling. Open the hood.
2. Remove the plastic inner fender then disconnect / remove the driver side charge air cooler (CAC) pipe using a 7/16" socket and ratchet to loosen clamps.



Note: Leave all clamps loose to allow movement.

3. Connect the 1302424 boot onto the supplied pipe using a 1405211 clamp.

Then connect the 1302425 & 1405404 boots onto the PAS valve using the 1407030 clamps.

With both assemblies completed, install the pipe assembly onto the CAC using the other 1405211 clamp.

Then install the valve assembly onto the intake using the 1405212 clamp.

Finally rotate and connect the two assemblies until aligned, then tighten all clamps till springs are bound. (1/2" socket)

Reinstall plastic inner fender.

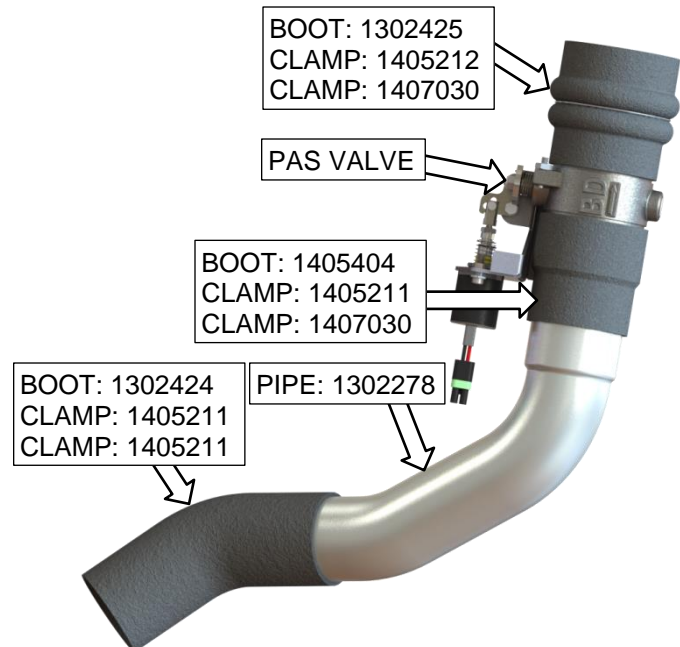
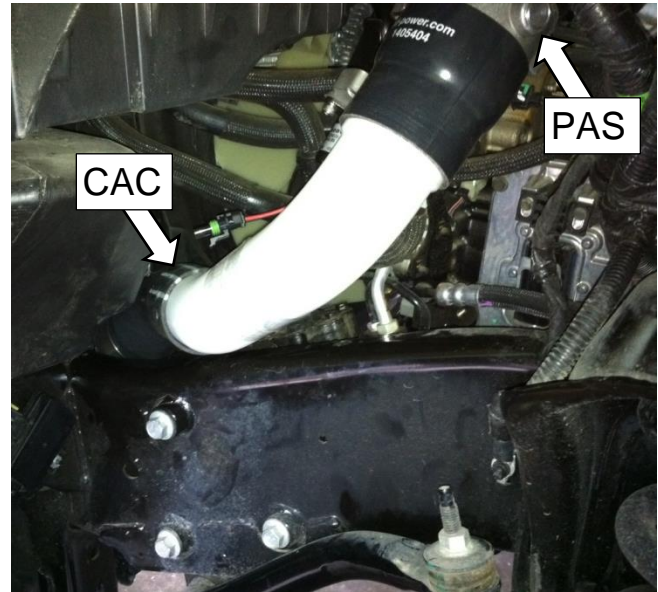

4. Once the PAS assembly is in place lay out the supplied harness over top of the driver's side of the engine.

You will then need to route the switch wires through the firewall (note you will need to remove the switch from the harness to accomplish this). See wiring diagram on page 16

Choose a highly visible location for the switch and mount it to the dash.

Using a 1/8" drill, drill a pilot hole in the location you have selected for the switch to be mounted.

Finally using a 1/2" UNIBIT drill bit, drill an exact 1/2" round hole.

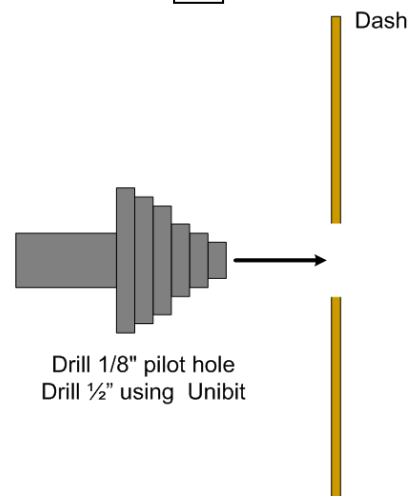

5. Once you have the mounting hole drilled, crimp the switch connectors to the switch wires and install the correct switch wires to the correct switch terminals, then insert the switch into the dash from the backside.

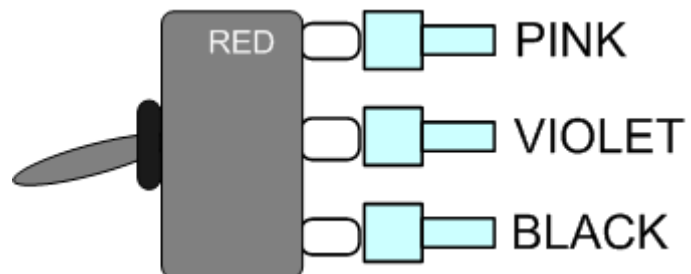

6. Mount the switch so that the groove on thread boss is facing down.

Adjust the HEX washer/nut so that the switch threads do not protrude an unsightly amount.

Switch install with decal

Apply the supplied decal to the dash and tighten the round plastic nut.

Switch install with Guard

Install the switch guard onto the switch by aligning the tab with the groove on the thread boss.

Then tighten on the round plastic nut and apply the decal to the switch guard.

Switch install with Decal

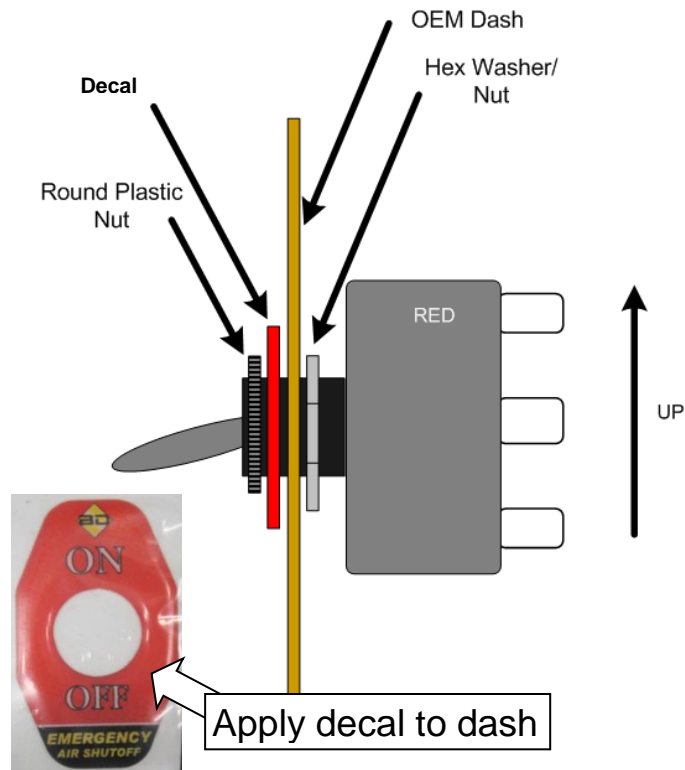

Switch Install with Guard

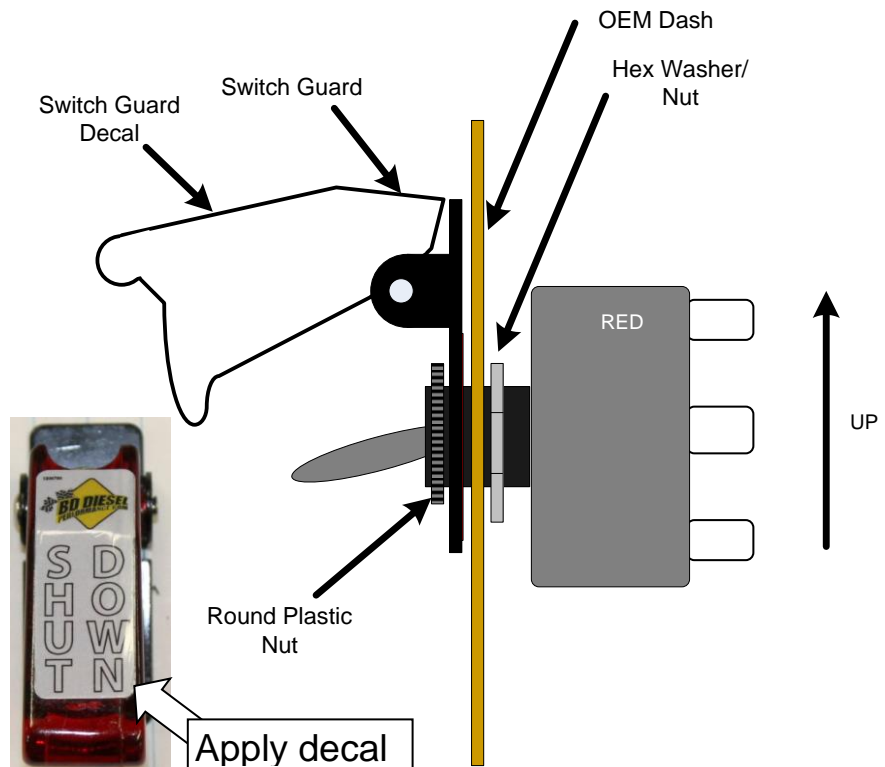

7. Locate and connect the weather pack connector on the wiring harness to the solenoid on the PAS valve.

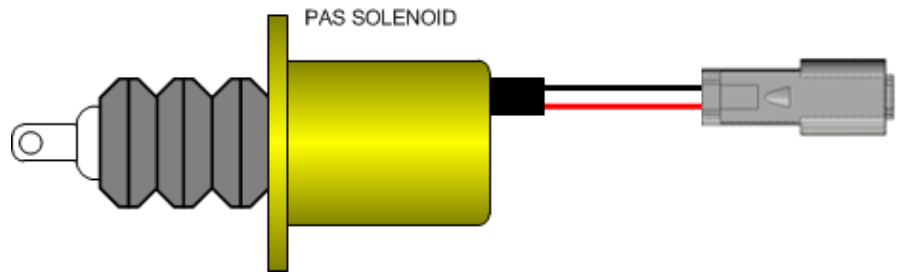

8. Next on the wiring harness, connect the BLACK and RED wires to the respective battery connections.
(Driver's Side Battery).

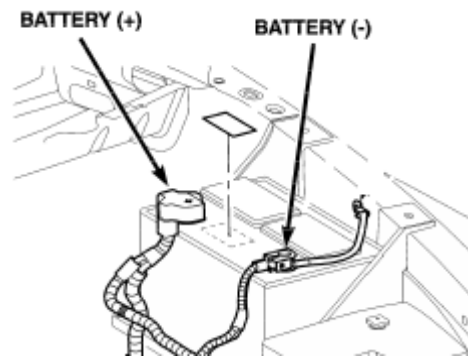

9. For the last connection you will need to locate ignition power.

Locate the fuse panel in front of the driver's side battery. Remove the cover.

Locate appropriate fused ignition power circuit. Connect pink wire with flag connector to this new connection. Route wire out of fuse box and close lid.



10. Double check all wiring connections and ensure wires are routed away from any heat sources and moving parts. Then install the loom with the supplied tee connector and clips for the loom ends and continue to the “Testing Flow Chart *without* Over Speed electronics” on page 24.

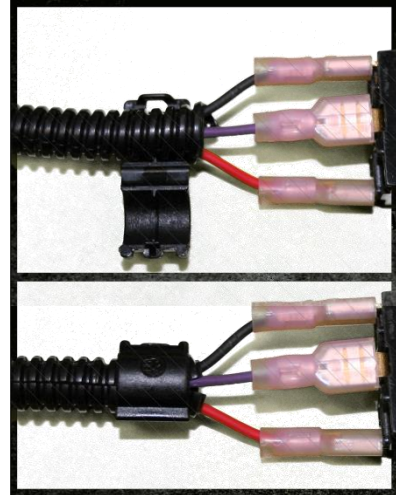
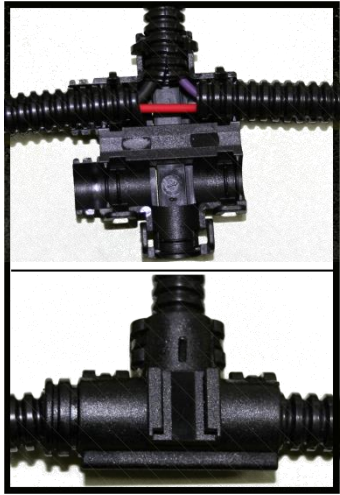

WIRING DIAGRAM with OVER SPEED ELECTRONICS (1036724)

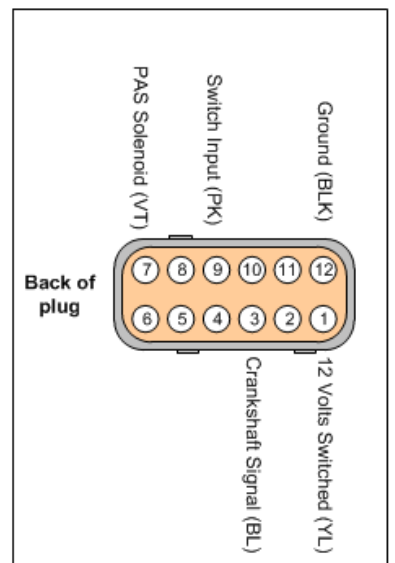
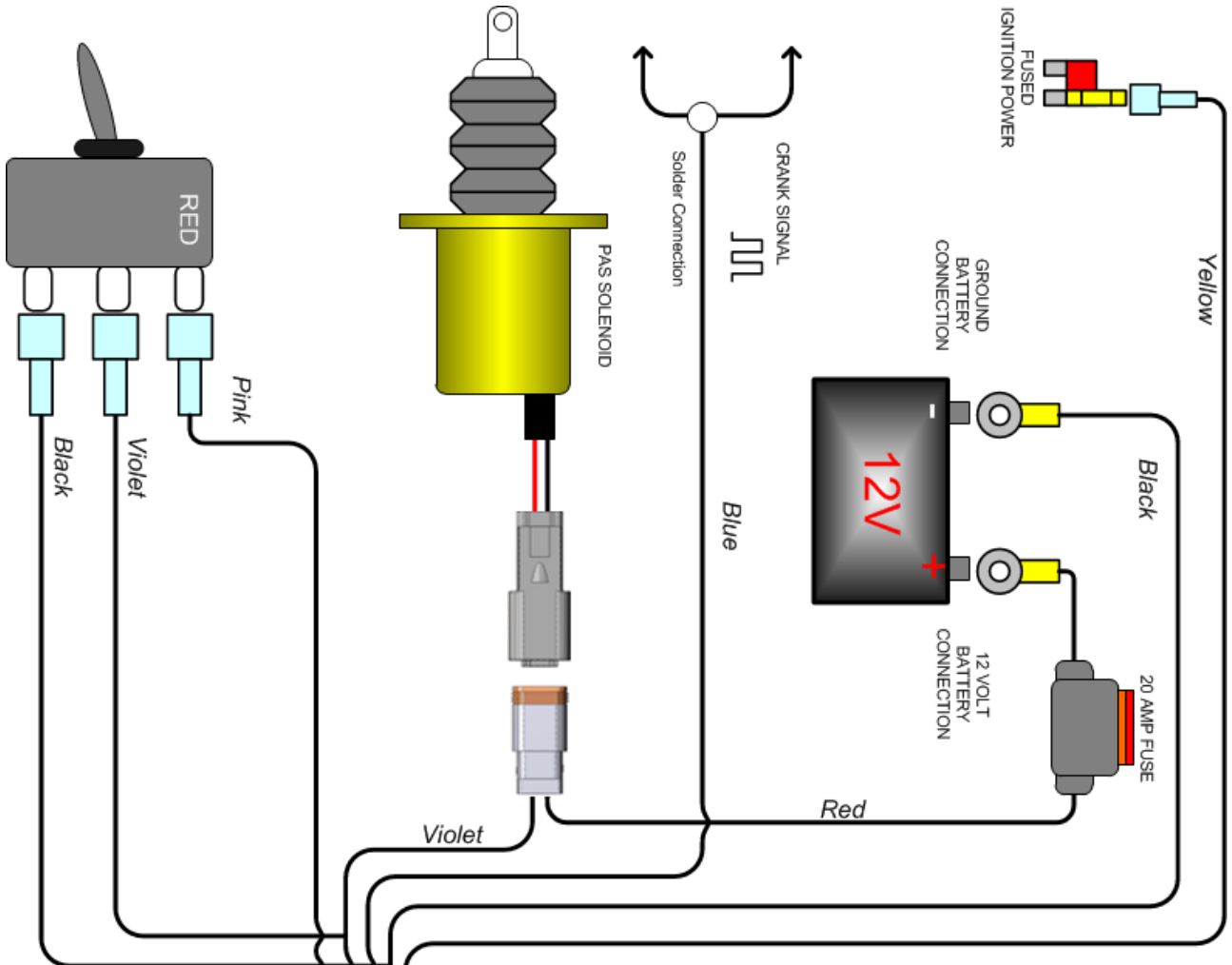

- POSITION 1 = Pre Programmed Automatic Mode (Vehicle Specific)
- POSITION 2 = Pre Programmed Test Mode
- POSITION 3 = Full Manual Mode (User must set)

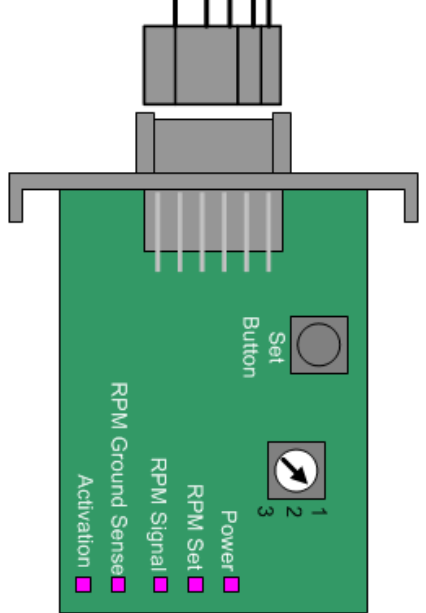

Application	Cutout RPM	Cutout Freq. (Hz)	Idle Freq. (Hz)
Dodge Cummins 1988-5/02	4200	3200	315
Dodge Cummins 2003-2013	4200	4200	750
Ford F75 Powerstroke	5000	4800	515
Ford F60 Powerstroke	5000	5000	750
Ford F60 Powerstroke	5000	5000	750
Ford F73 Powerstroke	4300	380	150
50 RPM & S.	4500	4800	750

WIRING DIAGRAM without OVER SPEED ELECTRONICS (1036724-M)

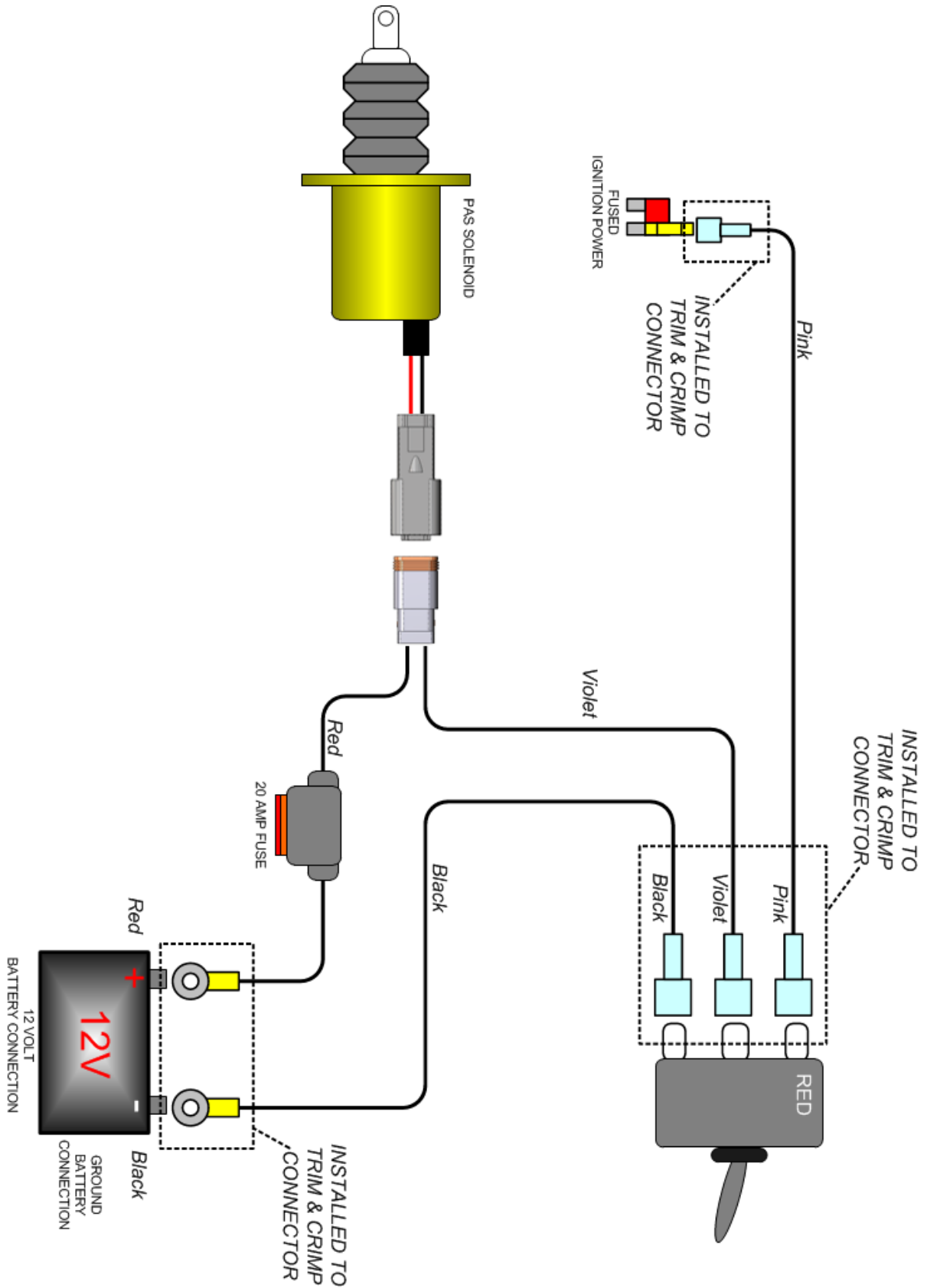

RESETTING THE VALVE

Valve Activated (Closed)

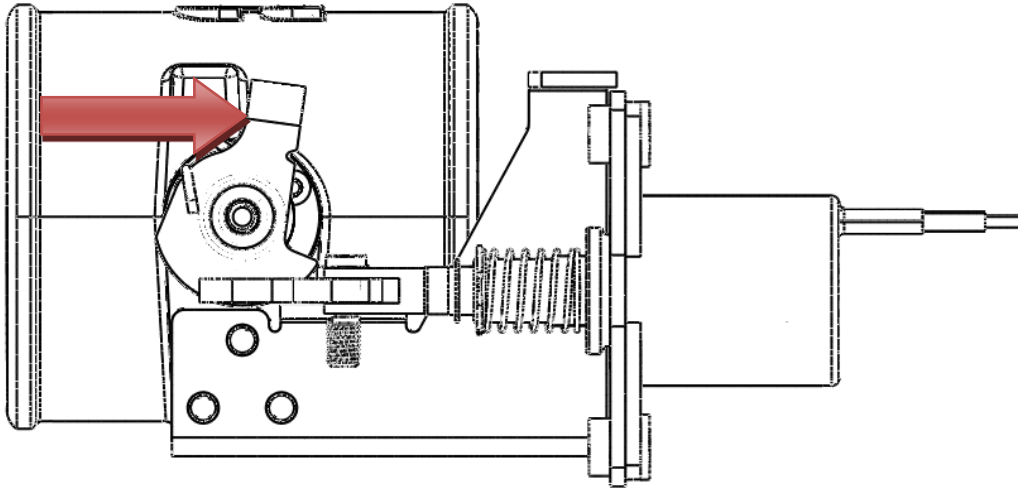

Valve Reset (Open)

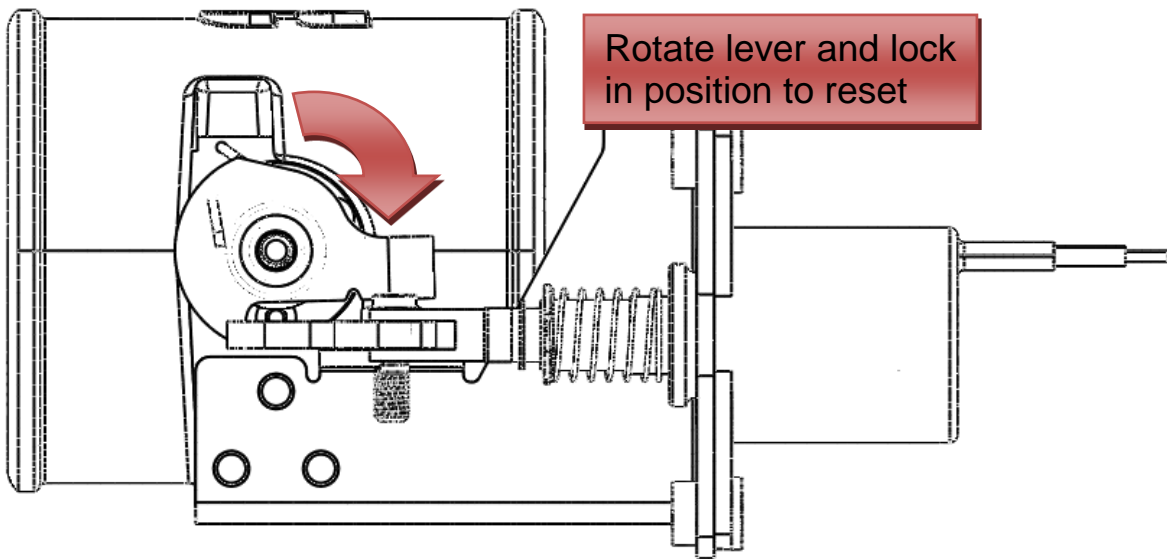

SETUP, TESTING AND VERIFICATION with OVER SPEED ELECTRONICS

Each unit is specifically configured for each model of truck. As in the case of different model years and makes the engine RPM frequency is different.

Engine Idle Speed Frequency
2013-2017 Dodge Cummins

600-800 Hz
(1:1) ratio

2013 Dodge Cummins	Activation RPM	Activation Freq. (Hz)
PAS Switch Position #1 (Automatic Mode)	4200	4200
PAS Switch Position #2 (Test Mode)	1200	1200
PAS Switch Position #3 (Manual Mode)	User Configured	User Configured

Automatic Mode (Pre Configured RPM)

Action	Failure/Fix/Notes
1. Turn the ignition key to the on position. You should see the RED light illuminate on the toggle switch.	If the LED does not illuminate, check the wiring to the back of the switch first. Then check entire circuit.
2. Next, start the engine. 3. With the engine idling, activate the toggle switch. You should hear the solenoid activate and the valve close. The engine should die. Once the engine dies the switch should flicker ON and OFF indicating a trip condition.	If the engine does not die, check to make sure the valve actuated. If the valve did not actuate check switch and ground wiring. If valve did actuate but the engine is still running, ensure nothing has contacted the valve mechanism
4. You can now reset the valve, by rotating the upper lever and engaging the solenoid stop.	

5. With the valve reset, remove the outer enclosure from the control module. There are two locking tabs on the sides of the enclosure.

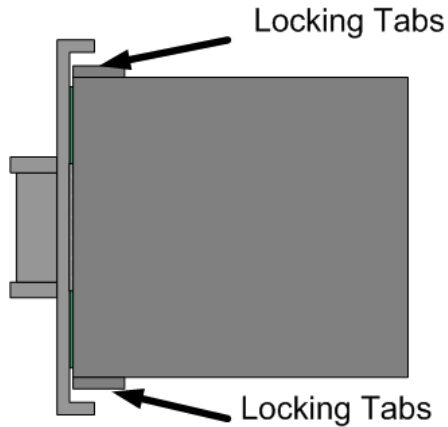

6. Change the position selection switch to position #2 (Auto Test). Slide enclosure cover over circuit board.

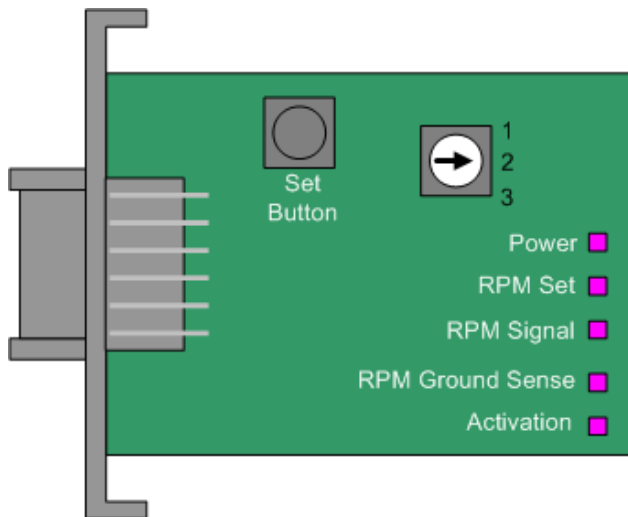

7. Start the vehicle, with the vehicle in park step on the throttle increasing the engine RPM. At 1200RPM the PAS should engage itself automatically, and the engine should stall. Like with all activations the

If the engine did not stall, check to make sure the valve actuated.
If the valve did not actuated, double check the engine RPM electrical connection.
Check the RPM Signal LED on the circuit

toggle switch should flash.	board, it should flash proportionally to the engine RPM.
<p>8. Reset the valve and reset the mode position switch to position #1</p>	
<p>You are now complete and the unit should function correctly. This test cycle should be completed once a year.</p>	

Manual Mode (User Configured RPM)

Setup

With the control unit, the user/installer has the ability to set their own activation RPM. It is necessary that you chose a low activation RPM first to test the unit is operating correctly. Once it has, you will need to set the high limit RPM activation.

Note: When you press the Set button the module will add 25% to the set speed.

1. Open electronic enclosure, by releasing the two locking tabs on the side of the unit.

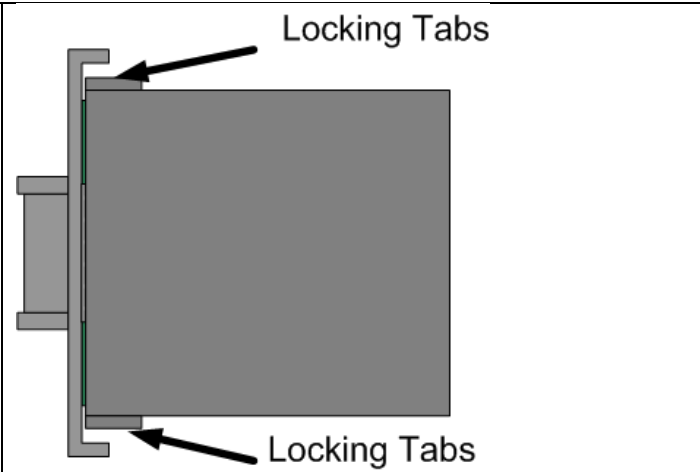

2. Adjust the position switch to Position #3.

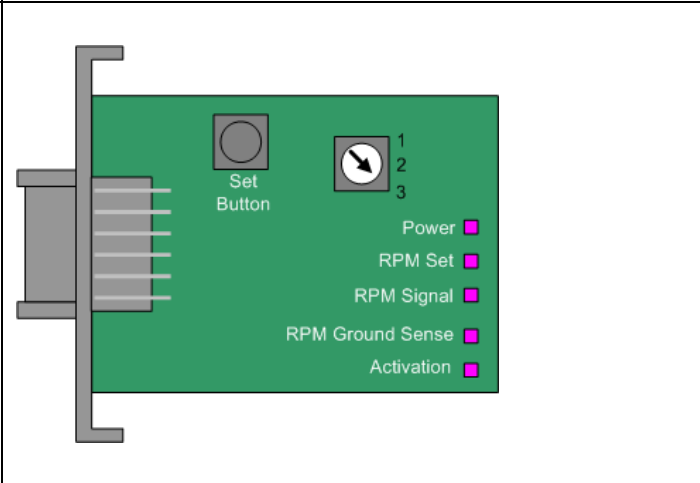
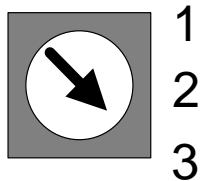

3. Start the engine.

4. Press and hold the RPM SET button.

When you push the SET RPM button you will see the "RPM Set" LED illuminate.

5. With another person helping you, have them step on the accelerator with the vehicle in park. Raise the engine RPM to 1200 RPM.

6. Release the SET RPM button.

Upon releasing the button the unit will store the $RPM + 25\%$. So for this example the unit has stored $1200RPM + 25\% = 1500RPM$.

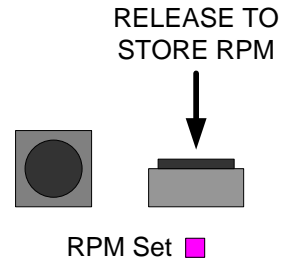
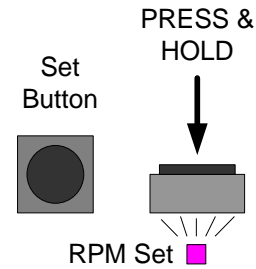

You should see the RPM signal flash proportionally to engine RPM.

7. Now increase the RPM of the engine to test the activation circuit is working correctly. As in this example the valve should activate at 1500RPM.

You should see the ACTIVATION LED flash ON/OFF on activation.

If the valve does not activate check the wiring.

If the valve activates but the engine does not stall, ensure nothing has contacted the valve linkage.

8. With the valve activated the engine should die. Reset the valve and restart the engine.

9. Press and hold the RPM SET button.

When you push the SET RPM button will see the "RPM Set" LED illuminate.

10. With another person helping you, have them step on the accelerator with the vehicle in park. Raise the engine RPM to MAXIMUM engine RPM.

11. Release the SET RPM button.

Upon releasing the button the unit will store the RPM + 25%. So for this example the unit has stored MAXIMUM engine RPM + 25%.

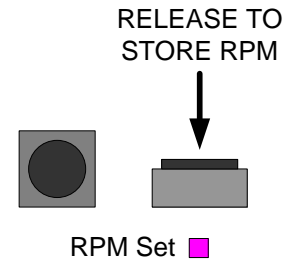
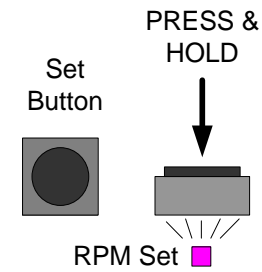

12. You can now put the electronic enclosure back together and secure it to the fuse box.

13. With the engine running you will need to test to make sure the manual activation switch is functioning correctly.

14. With the engine running, lift the activation switch and the engine should die.

15. Reset the valve and you are now complete.

If valve does not activate check the wiring.

If the valve activates and the engine does not die ensure nothing has contacted the linkage.

You have now completed the installation, please be sure to complete the test once a year to make sure the unit is functioning correctly.

TESTING FLOW CHART with OVER SPEED ELECTRONICS

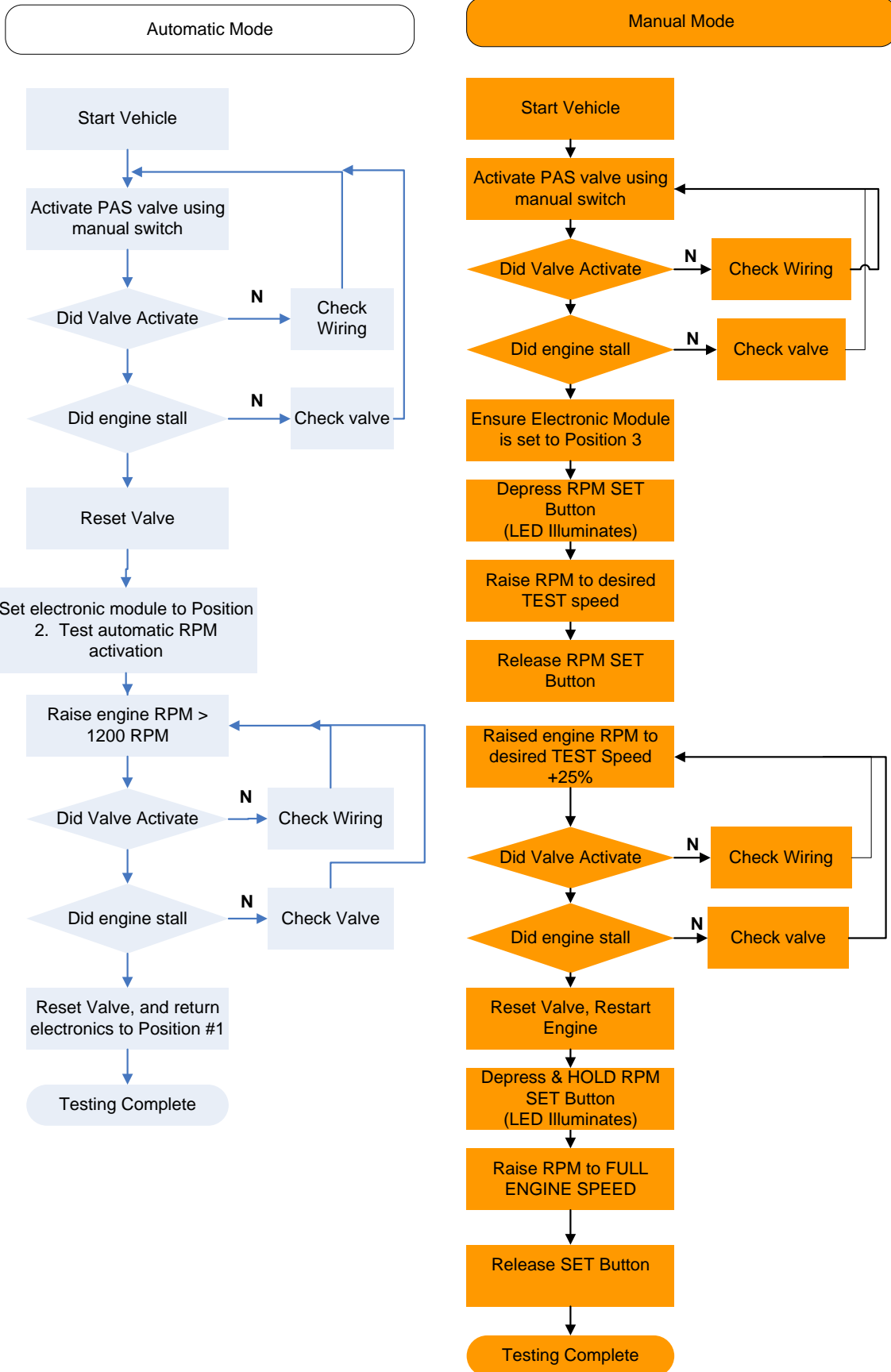

TESTING FLOW CHART without OVER SPEED ELECTRONICS

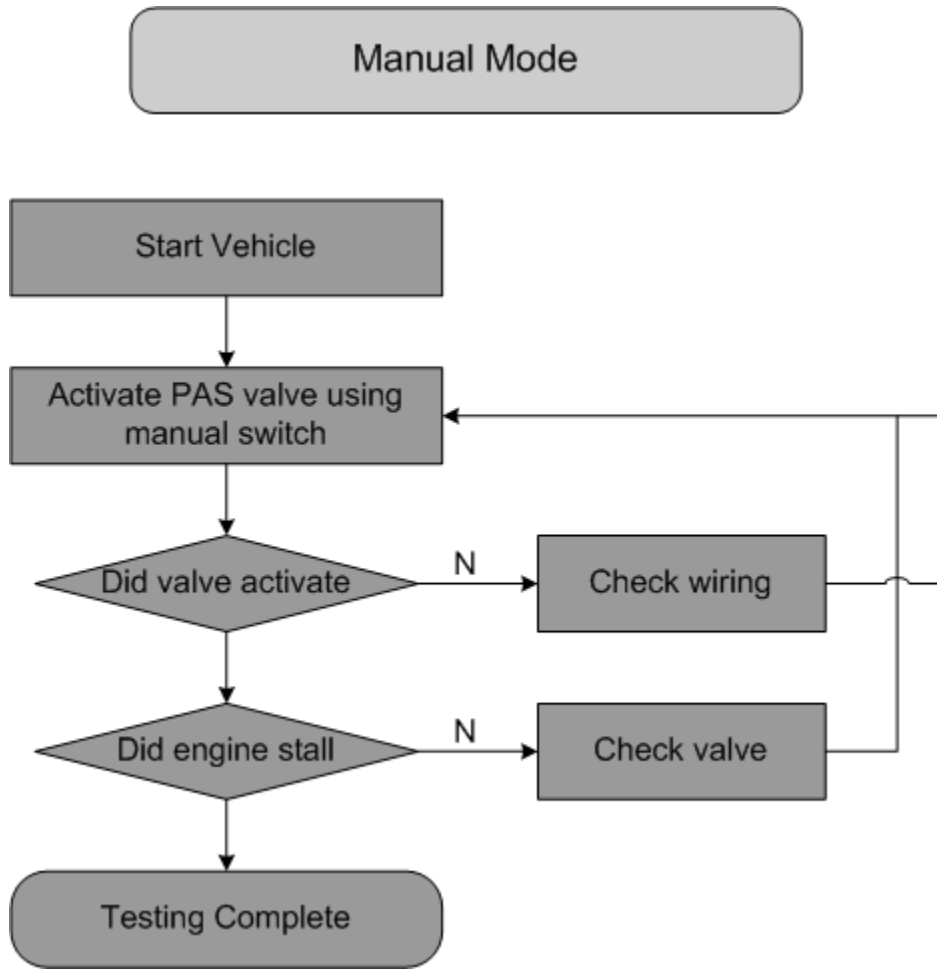

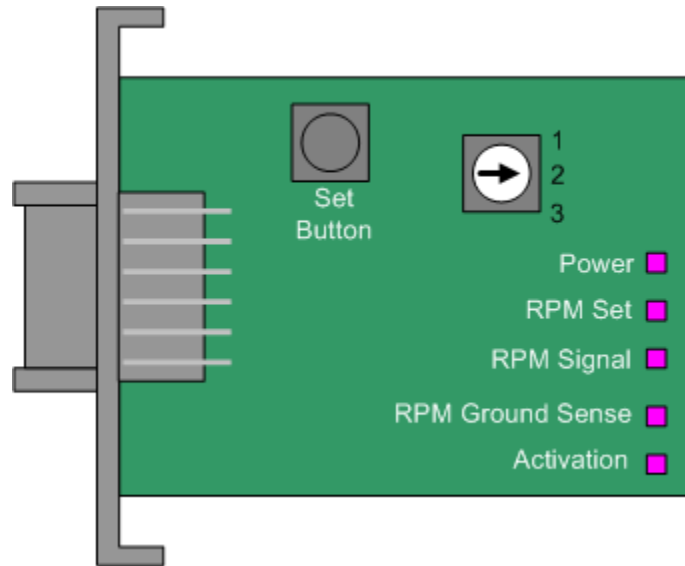
LED OPERATION

LED	Description
POWER	Illuminates when unit is POWERED
RPM SET	Illuminates when SET Button is Pressed
RPM Signal	Flashes proportional to Engine RPM
Ground Sense	Illuminates when a GROUND signal is sensed on the activation line
Activation	Flashes when a valve activation is command manually (switch) or automatically
Toggle Switch LED	The LED will flash indicating either a problem with the system (Loss of RPM or Power) or an activate valve activation.