



BD High Flow CP3 Pump Kit





For Dodge Cummins 03-16 5.9/6.7L

-- Installation Instructions --

P/N#	1050551
------	---------

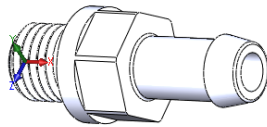
PLEASE READ ALL INSTRUCTIONS BEFORE INSTALLATION

In addition to the CP3, the kit contains the following for 5.9 Installations. 6.7 user do not need.

1604053	1502041	1500680	FT-0480748	1500403
				
3/8" Fuel Hose	3/8 Barb 12mm Fitting	High Pressure Outlet Fitting	O-ring 2mm x 9mm	Hose Clamp
Qty: 12"	Qty: 1	Qty: 1	Qty: 1	Qty: 2

Tools Required

- 17,19mm Wrench
- 13mm & 15/16" Socket
- 3/8" Ratchet
- Gear Puller
- 1 3/8" Socket (Filter)
- Torque Wrench (up to 77 ft/lbs)

For Dodge 6.7 Models,

This kit will contain fittings and hoses for 5.9 engines, 6.7 owners will not use those.

Removal



Caution: Cleanliness cannot be overemphasized when handling or replacing diesel fuel system components. This especially includes the fuel injectors, high-pressure fuel lines and fuel injection pump. Very tight tolerances are used with these parts. Dirt contamination could cause rapid part wear and possible plugging of fuel injector nozzle tip holes. This in turn could lead to possible engine misfire. Always wash/clean any fuel system component thoroughly before disassembly and then air dry. Cap or cover any open part after disassembly. Before assembly, examine each part for dirt, grease or other contaminants and clean if necessary. When installing new parts, lubricate them with clean engine oil or clean diesel fuel only.

1. Disconnect both negative battery cables at both batteries. Cover and isolate ends of both cables.
2. Remove intake manifold air intake tube (above injection pump) and its rubber connector hose.
3. Remove accessory drive belt.
4. Thoroughly clean rear of injection pump, and attachment points for its fuel lines. Also clean the opposite ends of these same lines at their attachment points.



Caution: Whenever a fuel line fitting is connected to a secondary fitting, always use a back-up wrench on the secondary fitting. Do not allow the secondary fitting to rotate.

5. Disconnect quick-connect fitting by pressing on button (1).

6. Remove high-pressure fuel line to fuel rail.

7. Remove banjo bolt (2).

8. Disconnect FCA (Fuel Control Actuator) electrical connector (3).

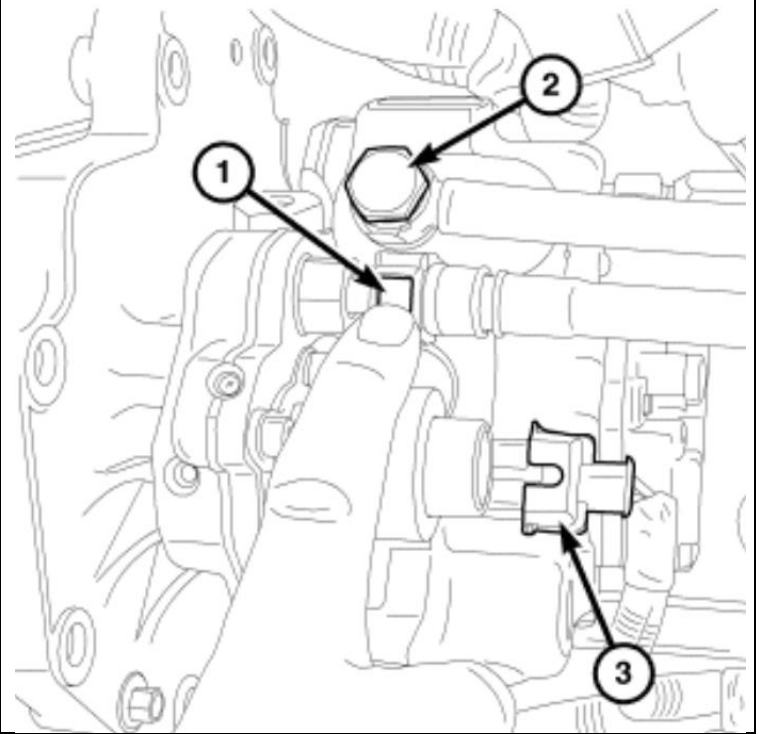

9. Remove line clamp (5).

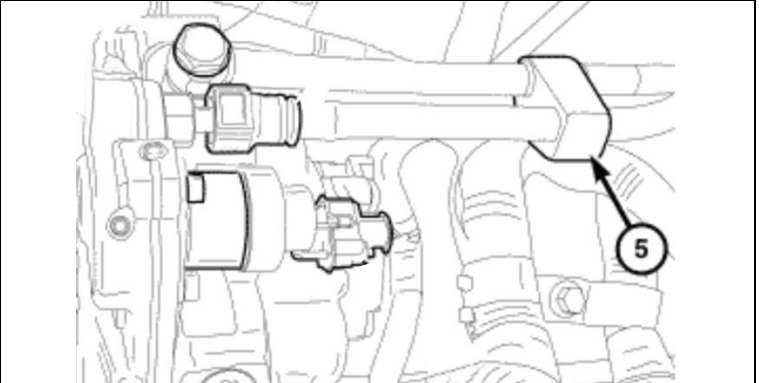

10. Remove fuel pump drive gear access cover with a 3/8" drive ratchet. Access cover (2) is threaded to timing gear cover.

Number	Description
1	Front Timing Gear Cover
2	Gear Access Plate (Cover)
3	Square Drive (For Cover Removal)

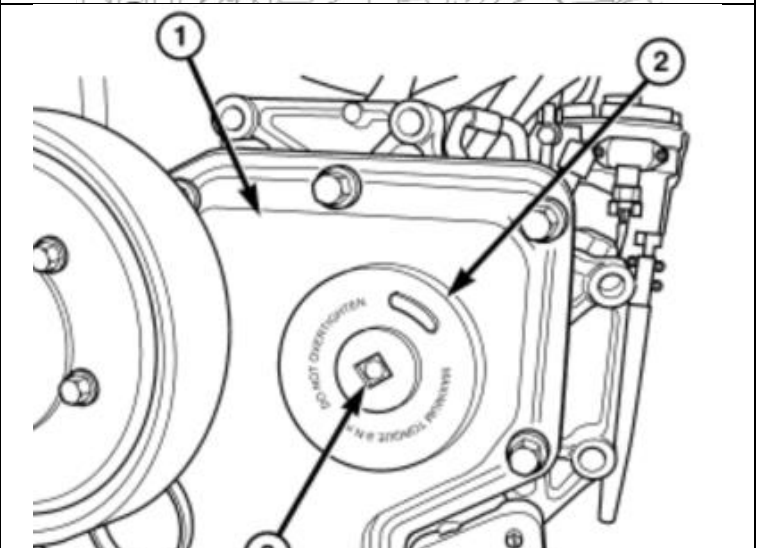

11. Remove fuel pump drive gear mounting nut and washer.

12. Attach C3428B, or L4407A (or equivalent) gear puller to pump drive gear with 2 bolts, and separate gear from pump (a keyway is not used on this particular injection pump). Leave drive gear hanging loose within timing gear cover.

<u>Number</u>	<u>Description</u>
1	Front Timing Gear Cover
2	Gear Puller Tool

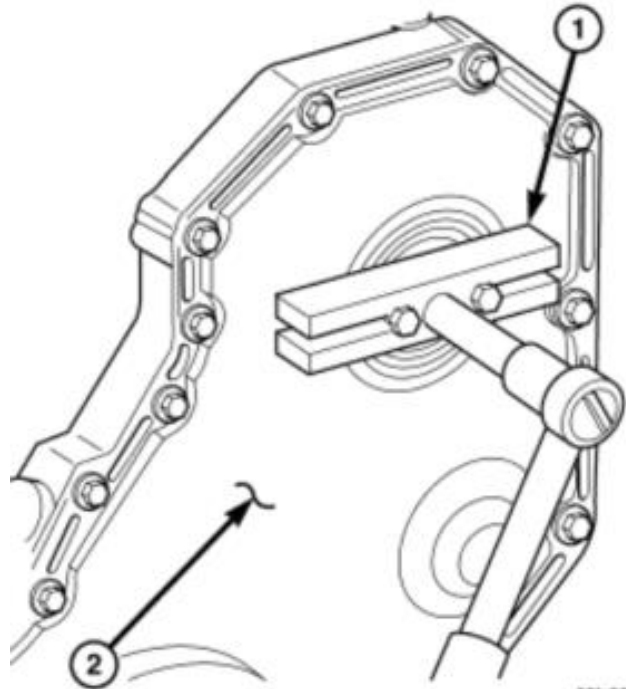

13. Remove three injection pump mounting nuts (6), and remove pump from engine.

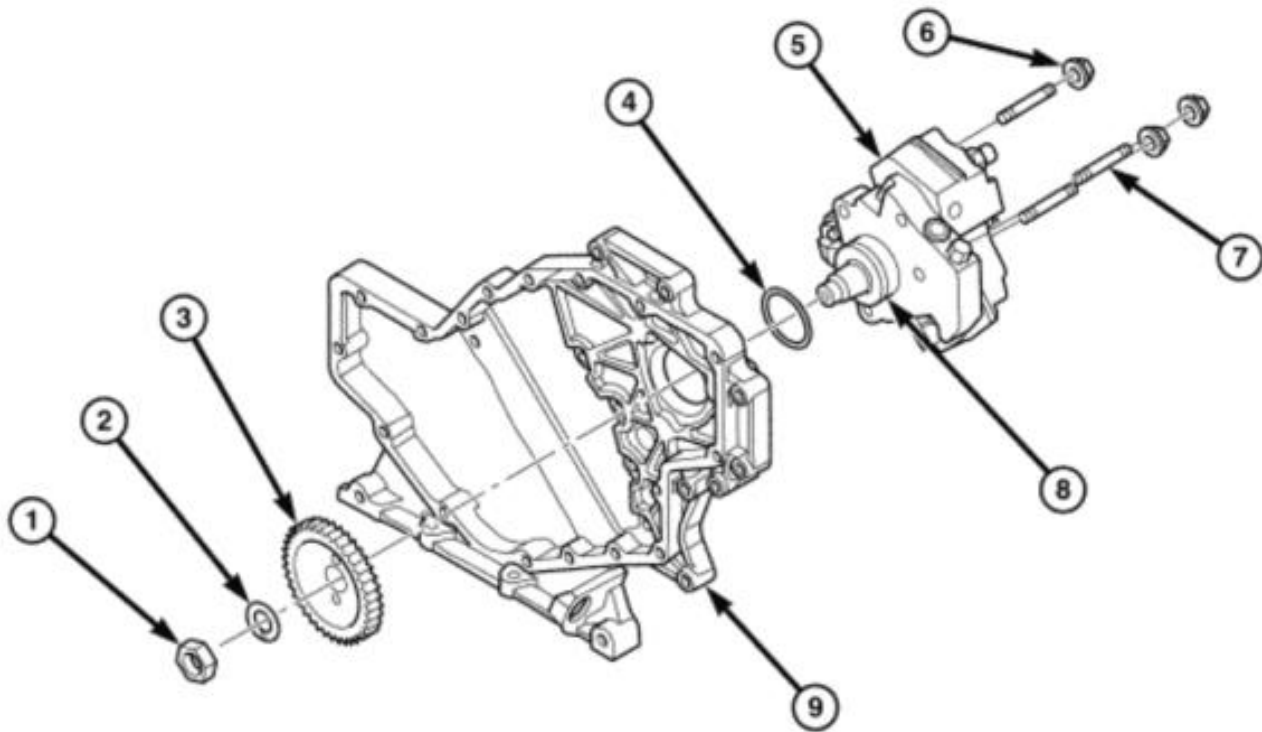

<u>Number</u>	<u>Description</u>	<u>Number</u>	<u>Description</u>
----------------------	---------------------------	----------------------	---------------------------

1	Pump Drive Gear Nut	6	Pump Mounting Nuts
2	Washer	7	Pump Mounting Studs
3	Pump Drive Gear	8	O-Ring Machined Groove
4	Rubber O-ring	9	Front Timing Gear Housing
5	Fuel Injection Pump		

Installation 6.7 Motors



Caution: Cleanliness cannot be overemphasized when handling or replacing diesel fuel system components. This especially includes the fuel injectors, high-pressure fuel lines and fuel injection pump. Very tight tolerances are used with these parts. Dirt contamination could cause rapid part wear and possible plugging of fuel injector nozzle tip holes. This in turn could lead to possible engine misfire. Always wash/clean any fuel system component thoroughly before disassembly and then air dry. Cap or cover any open part after disassembly. Before assembly, examine each part for dirt, grease or other contaminants and clean if necessary. When installing new parts, lubricate them with clean engine oil or clean diesel fuel only.

1. Inspect pump mounting surfaces at pump and mounting flange and pilot bore for nicks, cuts or damage. Inspect O-ring surfaces for nicks, cuts or damage.
2. Clean injection pump mounting flange and pilot bore at gear housing. Also clean front of injection pump.
3. Apply clean engine oil **to injection pump O-ring and pilot bore only. The machined tapers on both injection pump shaft and injection pump gear must be absolutely dry, clean and free of any dirt or oil film. This will ensure proper gear-to-shaft tightening.**
4. Clean pump gear and pump shaft at machined tapers with an evaporative type cleaner such as brake cleaner.
5. **FUEL INJECTION PUMP PHASING:** Perform the following phasing procedure anytime the injection pump has been removed and re-installed.

6. Locate the end of the fuel injection pump shaft, a “line” is stamped into the end of the shaft.

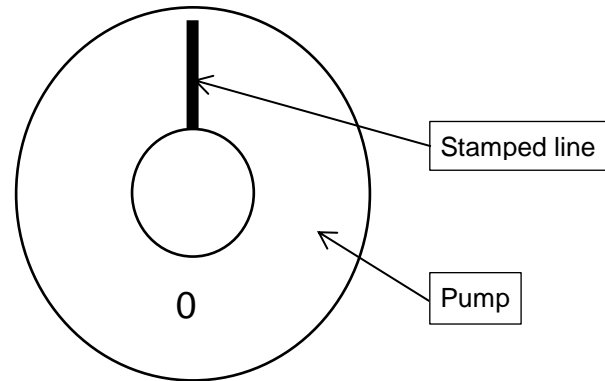

7. Rotate the injection pump shaft until the “line” is positioned at 9 o'clock (1).

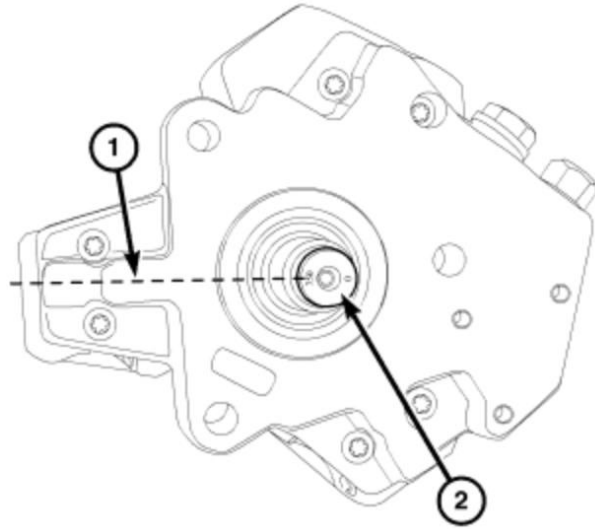

8. Position injection pump to mounting flange on gear housing while aligning injection pump shaft through back of injection pump gear. Be sure the “line” is still at the 9 o'clock position (1).
9. Bring the engine to TDC position. Do this by rotating the crankshaft until the TDC mark on the crankshaft damper is at 12 o'clock position. It does not matter if cylinder #1 or #6 is at TDC. Again, check to be sure the “line” is still at the 9 o'clock position (1). Rotate pump shaft accordingly.

Number	Description
1	Pump Drive Gear Nut
2	Washer
3	Pump Drive Gear
4	Rubber O-ring
5	Fuel Injection Pump
6	Pump Mounting Nuts
7	Pump Mounting Studs
8	O-Ring Machined Groove
9	Front Timing Gear Housing

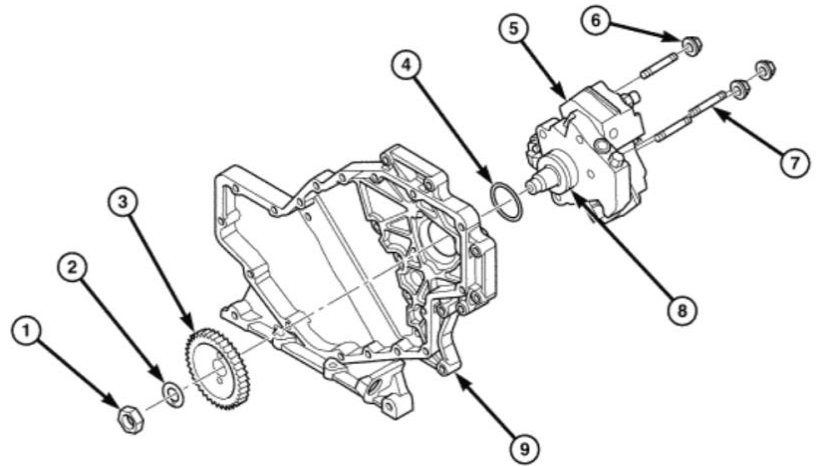

10. After pump is positioned flat to mounting flange, install three pump mounting nuts (6) and tighten **finger tight only**. Do not attempt a final tightening at this time. **Do not attempt to tighten (pull) pump to gear housing using mounting nuts. Damage to pump or gear housing may occur. The pump must be positioned flat to its mounting flange before attempting to tighten three mounting nuts.**

11. To prevent damage or cracking of components, install and tighten nuts in the following sequence:

Install injection pump shaft washer and nut to pump shaft. Tighten nut **finger tight only**.

- Do preliminary (light) tightening of injection pump shaft nut (1).
- Tighten three injection pump mounting nuts to 24 N.m (18 ft. lbs.).
- Do a final tightening of pump shaft nut (1) to 105 N.m (77 ft. lbs.).

Number	Description
1	Front Timing Gear Cover
2	Gear Access Plate (Cover)
3	Square Drive (For Cover Installation)

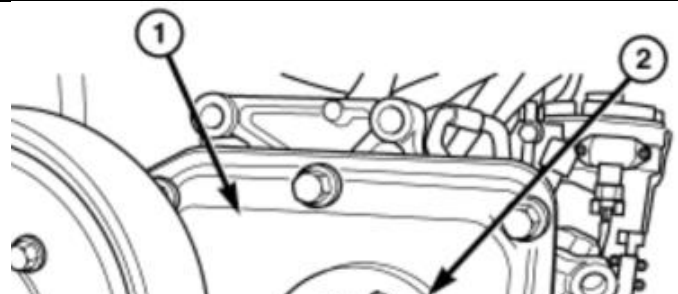

12. Install drive gear access cover (2) using a 3/8" drive ratchet. Access cover is threaded to timing gear cover. Tighten to 8 N.m (71 in. lbs.) torque.

13. Install fuel return line. Tighten banjo bolt (2) to 24 N.m (18 ft. lbs.) torque.

14. Install quick-connect fitting (4).

15. Install fuel line (injection pump-to-fuel rail). Using a backup wrench, tighten fitting at fuel pump to 40 N.m (30 ft. lbs.) torque. Tighten fitting at fuel rail to 40 N.m (30 ft. lbs.) torque.

16. Install clamp (5).

17. Connect Fuel Control Actuator (FCA) electrical connector (6) to rear of injection pump.

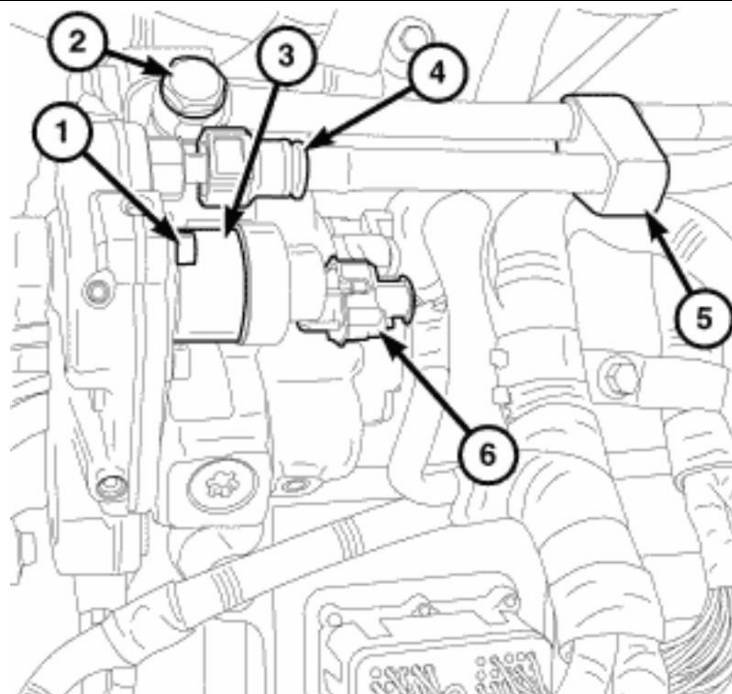

18. Install rubber intake manifold air intake tube (2). Tighten clamps (4).

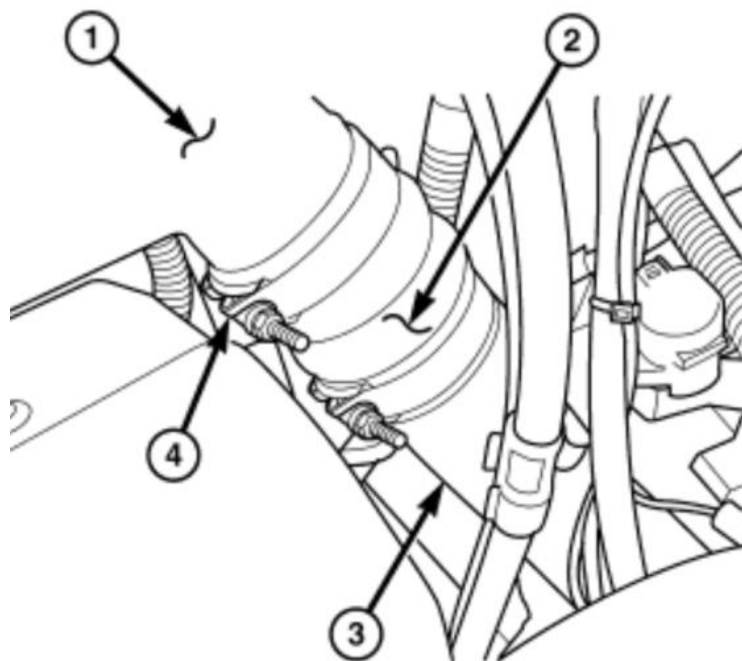

19. Install accessory drive belt.



20. Connect both negative battery cables to both batteries.

21. Check system for fuel or engine oil leaks.

For Dodge 5.9 Models,

This kit contains, small fuel fittings and hoses, as a 5.9 owner you will need these.

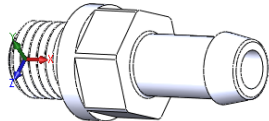
In addition to the CP3, the kit contains the following for 5.9 Installations. 6.7 user do not need.

1604053	1502041	1500680	1500403
			
3/8" Fuel Hose	3/8 Barb 12mm Fitting	High Pressure Outlet Fitting	Hose Clamp
Qty: 12"		Qty: 2	

Removal Procedure

CAUTION: Cleanliness cannot be overemphasized when handling or replacing diesel fuel system components. Very tight tolerances are used with these parts. Dirt contamination could cause rapid part wear. Always wash/clean any fuel system component thoroughly before disassembly and then air dry. Cap or cover any open part after disassembly. Before assembly, examine each part for dirt, grease or other contaminants and clean if necessary. When installing new parts, lubricate them with clean engine oil or clean diesel fuel only.

1. Disconnect both negative battery cables at both batteries. Cover and isolate ends of both cables.
2. Remove intake manifold air intake tube (above injection pump) and its rubber connecting hose.
3. Remove accessory drive belt.

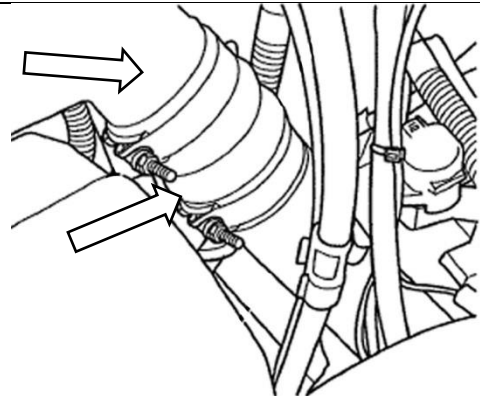

4. Thoroughly clean the rear of injection pump, and attachment points for its 3 fuel lines (Feed (1), Return Line (2) and High Pressure Line (3)).

Also clean the opposite ends of these same 3 lines at their attachment points.

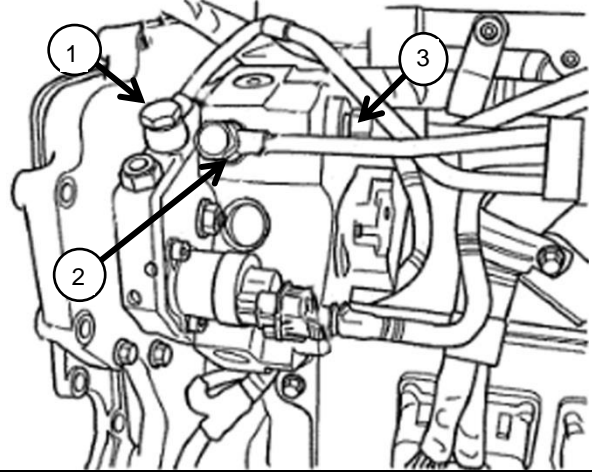

5. Disconnect Fuel Control Actuator (FCA) electrical connector (1) at rear of injection pump.

CAUTION: Whenever a fuel line fitting is connected to a secondary fitting, always use a back-up wrench on the secondary fitting. Do not allow the secondary fitting to rotate.

6. Completely remove CP3 feed line (injection pump-to-fuel pressure limiting valve). (19mm wrench). This will be replaced.

7. Remove return line (injection pump-to-fuel filter housing). (19mm wrench)

8. Remove high pressure line (injection pump-to-fuel rail). Use back-up wrench on fitting at fuel pump. (19mm wrench)

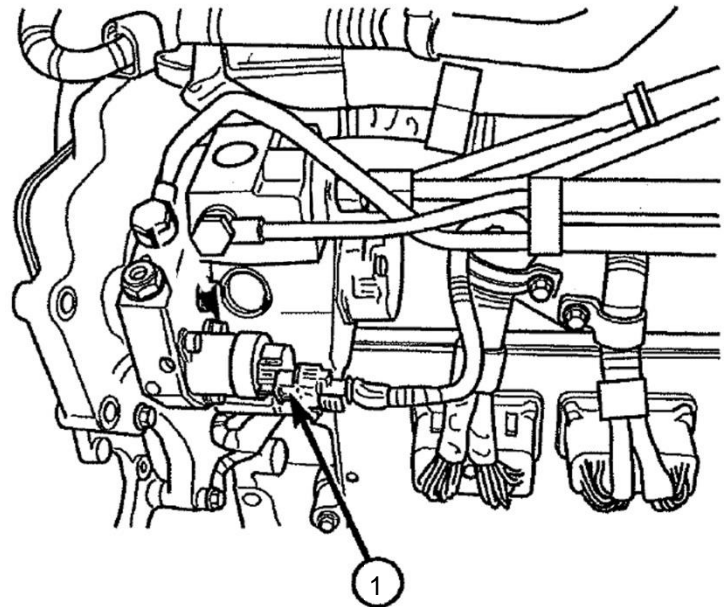

9. Remove fuel pump drive gear access cover with a 3/8" drive ratchet. Access cover (2) is threaded to timing gear cover (1).

10. Remove fuel pump drive gear mounting nut and washer. (1 1/16" socket)

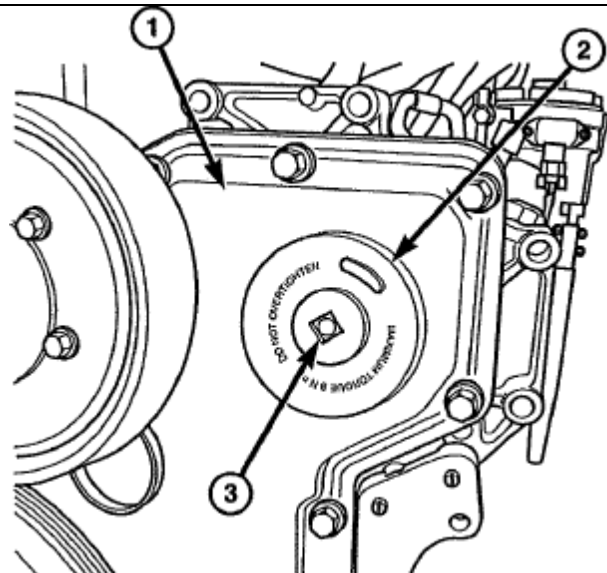

11. Attach C3428B, or L4407 A (or equivalent) gear puller (1) to pump drive gear with two bolts (M8-1.25), and separate gear from pump (a keyway is not used on this particular injection pump). Leave drive gear hanging loose within timing gear housing.

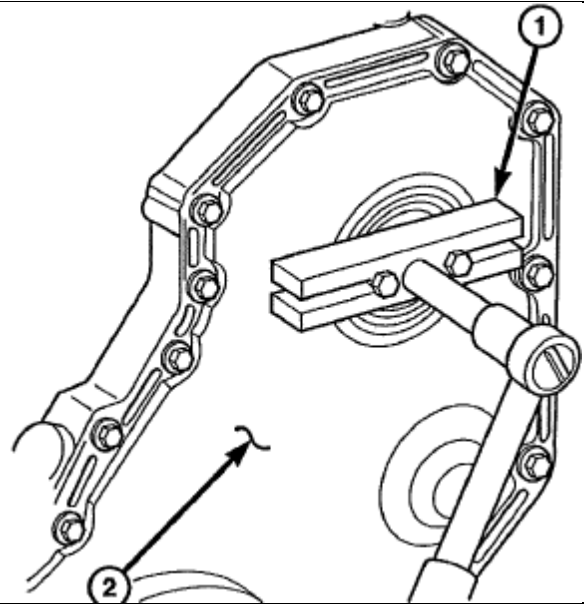

12. Remove 3 injection pump mounting nuts (6), and remove pump from engine.

1 - PUMP DRIVE GEAR NUT
2 - WASHER
3 - PUMP DRIVE GEAR
4 - RUBBER O-RING
5 - FUEL INJECTION PUMP
6 - PUMP MOUNTING NUTS (3)
7 - PUMP MOUNTING STUDS (3)
8 - O-RING MACHINED GROOVE
9 - FRONT TIMING GEAR HOUSING

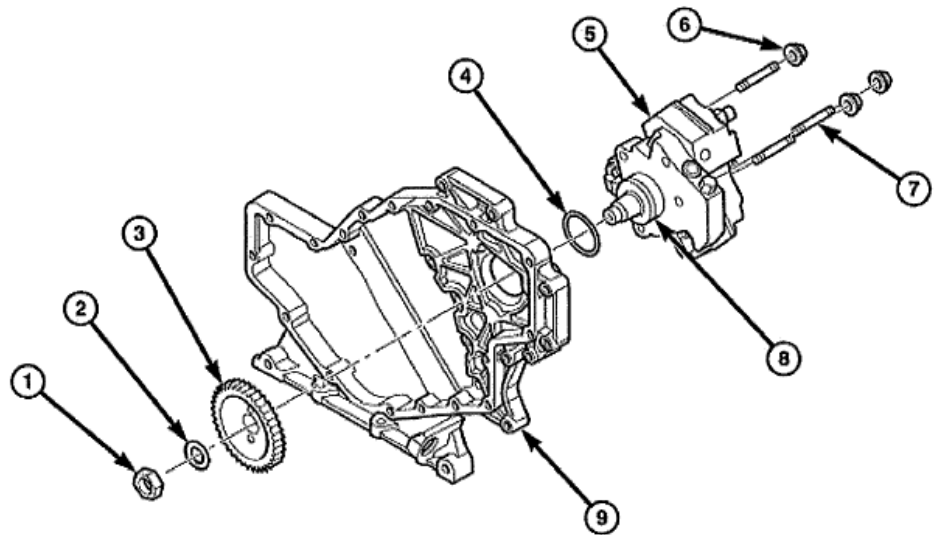

INSTALLATION 5.9 Motors

CAUTION: Cleanliness cannot be overemphasized when handling or replacing diesel fuel system components. This especially includes the fuel injectors, high-pressure fuel lines and fuel injection pump. Very tight tolerances are used with these parts. Dirt contamination could cause rapid part wear and possible plugging of fuel injector nozzle tip holes. This in turn could lead to possible engine misfire. Always wash/clean any fuel system component thoroughly before disassembly and then air dry. Cap or cover any open part after disassembly. Before assembly, examine each part for dirt, grease or other contaminants and clean if necessary. When installing new parts, lubricate them with clean engine oil or clean diesel fuel only.

1. Inspect pump mounting surfaces and pilot bore on pump and gear housing for nicks, cuts or damage. Inspect O-ring surfaces for nicks, cuts or damage.
2. Clean injection pump mounting flange and pilot bore at gear housing. Also clean front of injection pump.
3. Install new rubber O-ring (square) into machined groove on pump mounting area.
4. Apply clean engine oil to injection pump O-ring and pilot bore only.
The machined tapers on both injection pump shaft and injection pump gear must be absolutely dry, clean and free of any dirt or oil film. This will ensure proper gear-to-shaft tightening.
5. Clean pump gear and pump shaft at machined tapers with an evaporative type cleaner such as brake cleaner.
6. ***IMPORTANT*** - Fuel Injection Pump Phasing procedure is required before installation of the new pump.

FUEL INJECTION PUMP PHASING: Perform the following phasing procedure anytime the injection pump has been removed and re-installed.

Locate the end of the fuel injection pump shaft, a "line" is stamped into the end of the shaft.

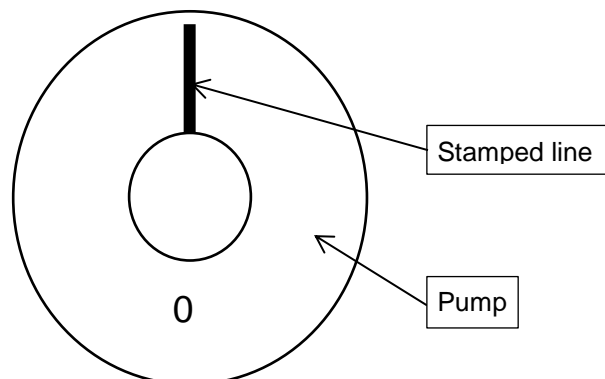

Rotate the injection pump shaft until the “line” is positioned at 9 o'clock (1).

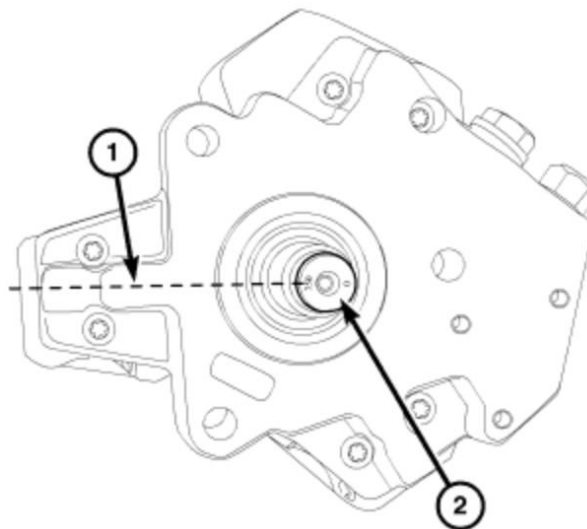

Position injection pump to mounting flange on gear housing while aligning injection pump shaft through back of injection pump gear. Be sure the “line” is still at the 9 o'clock position (1).

Bring the engine to TDC position. Do this by rotating the crankshaft until the TDC mark on the crankshaft damper is at 12 o'clock position. It does not matter if cylinder #1 or #6 is at TDC. Again, check to be sure the “line” is still at the 9 o'clock position (1). Rotate pump shaft accordingly.

7. Once shaft is correctly aligned and pump is positioned flat to mounting flange, install 3 pump mounting nuts and tighten finger tight only. Do not attempt a final tightening at this time. Do not attempt to tighten (pull) pump to gear housing using mounting nuts. Damage to pump or gear housing may occur. The pump must be positioned flat to its mounting flange before attempting to tighten 3 mounting nuts.
8. To prevent damage or cracking of components, install and tighten nuts in the following sequence:
 - a. Install injection pump shaft washer and nut to pump shaft. Tighten nut finger tight only.
 - b. Do preliminary (light) tightening of injection pump shaft nut.
 - c. Tighten 3 injection pump mounting nuts to 24 N'm (18 ft. lbs.).
 - d. Do a final tightening of pump shaft nut to 105 N'm (77 ft.lbs.).
9. Install drive gear access cover using a 3/8" drive ratchet. Access cover is threaded to timing gear cover. Tighten to 8 N'm (6 ft/lbs.) torque.
10. BD has included a new High Pressure Output fitting. You will need to remove OE 6.7 fitting and install the supplied BD fitting. Transfer the spring and check ball. Reinstall fitting.

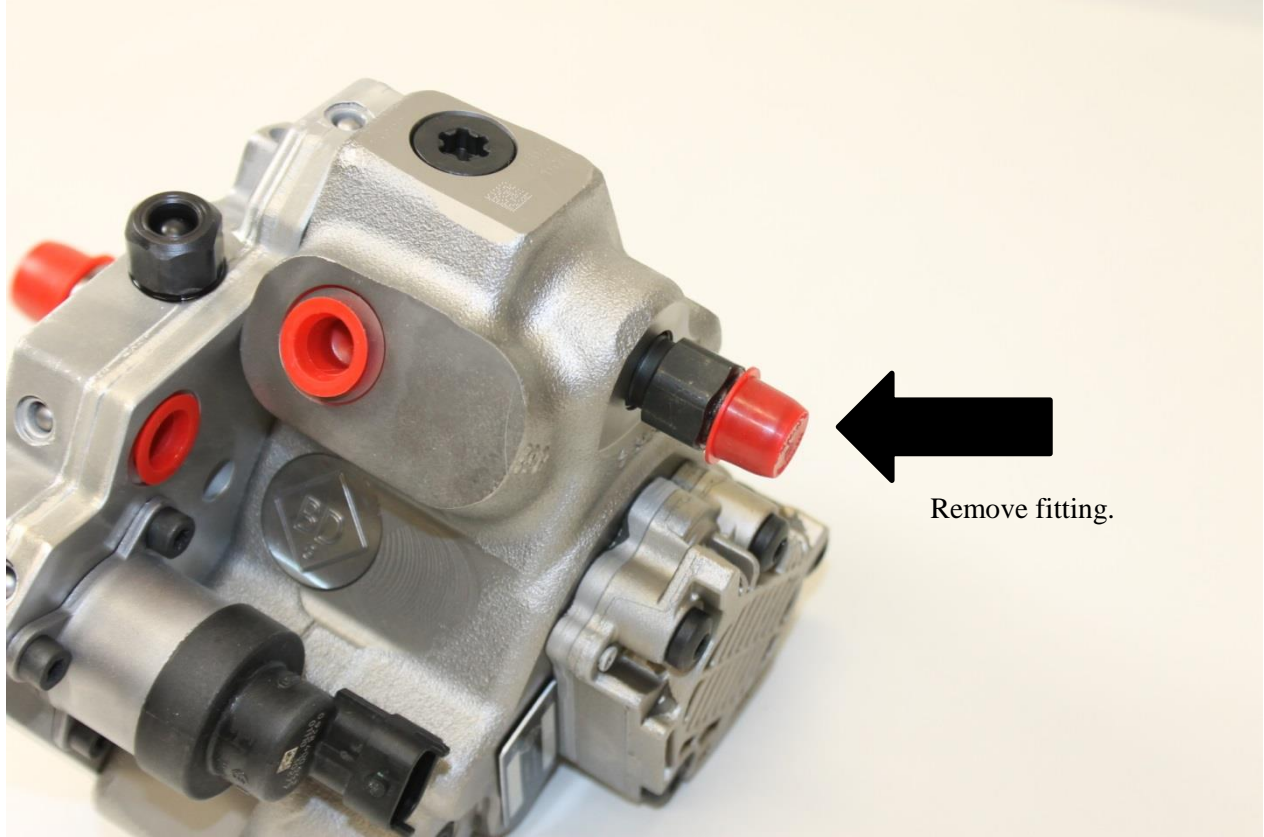

Transfer Ball and Spring to # 1500680 BD fitting.

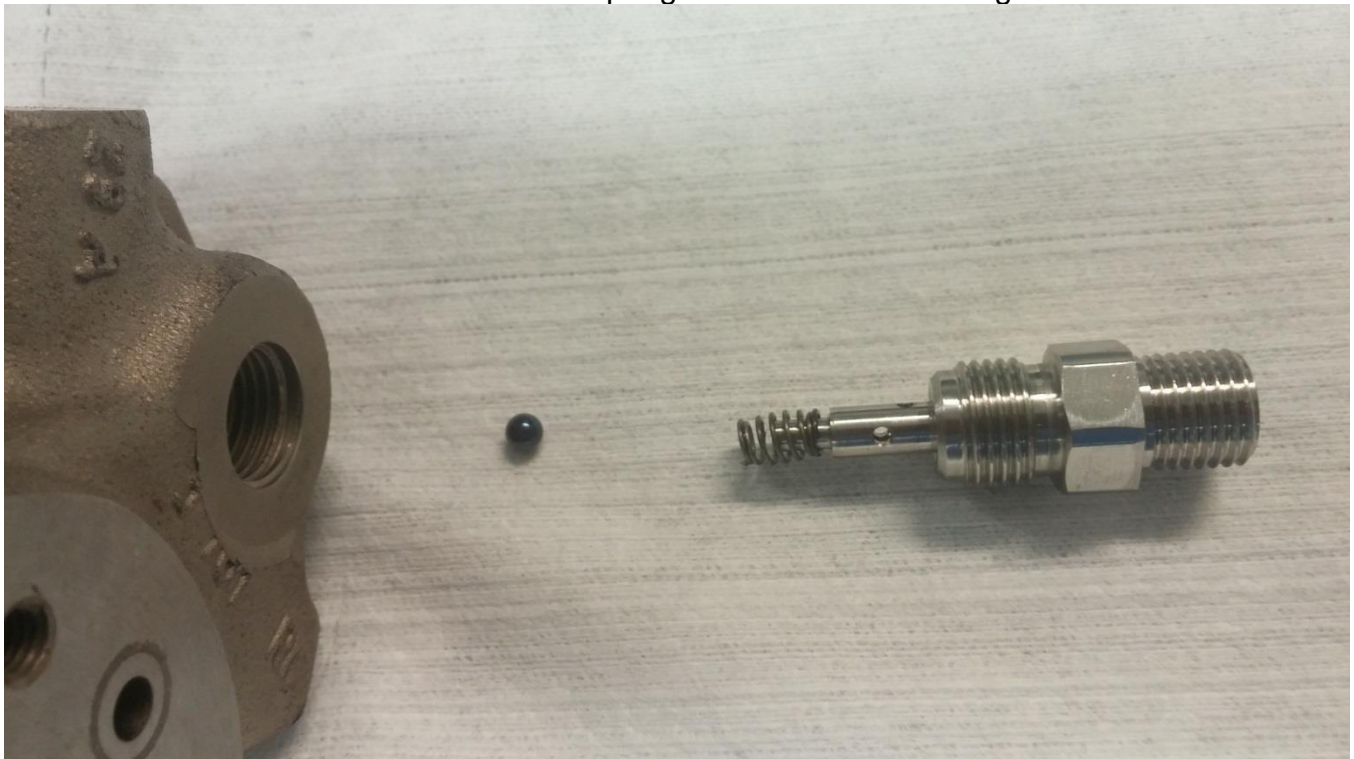

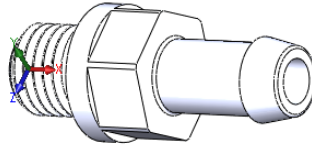

Install #1502041 3/8 Barb Fuel Supply fitting here. Remove Oring from QC fitting and transfer to new fitting.

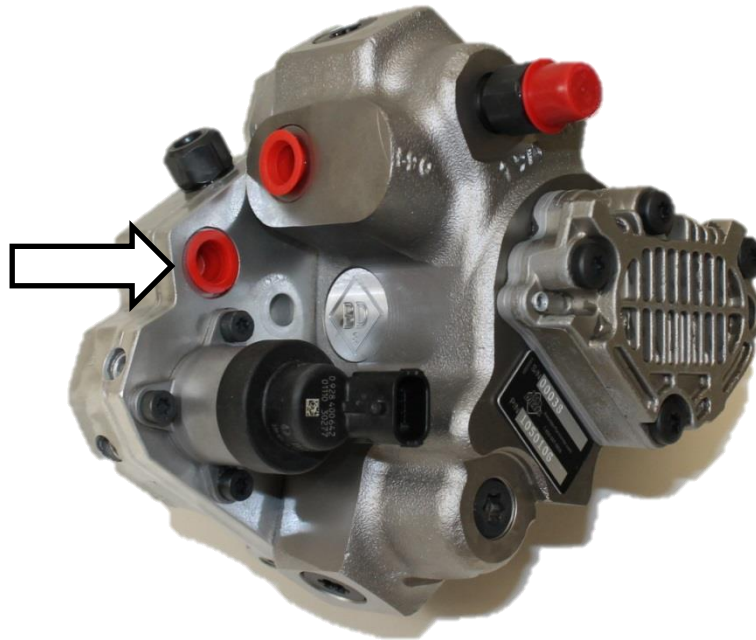

Install fuel line (injection pump-to-fuel rail). Note with the BD High Performance pump you may need to tweak/bend the factory high pressure line.

- a. Tighten Fuel line fitting at fuel pump to 37 N'm (27 ft. lbs.) torque. Use a back-up wrench.
- b. Tighten Fuel line fitting at fuel rail to 37 N'm (27 ft. lbs.) torque.

11. Install fuel return line (injection pump-to-fuel filter). Tighten banjo bolts to 24 N'm (18 ft. lbs.) torque.

12. BD has supplied a new fuel inlet fitting **#1502041** in the CP3 . You will need to discard the factory hard line if you have not already. Use the **#1500403** spring clamps and the 12" section of **3/8" fuel hose** to connect to the fuel filter.

Note BD has 1/2" fittings available for high performance applications # 1502040.

13. Connect Fuel Control Actuator (FCA) electrical connector to rear of injection pump.

14. Install intake manifold air intake tube (above injection pump). Tighten clamps.
15. Install accessory drive belt.
16. Install new fuel filter (recommended).
17. Connect both negative battery cables to both batteries.
18. Check system for fuel or engine oil leaks.