



Flowmax Filter Kits





Installation Instructions

This kit is designed for V3 Flomax pumps only

P/N#	1050340-PFF
P/N#	1050340-WSP

PLEASE READ ALL INSTRUCTIONS CAREFULLY BEFORE INSTALLATION.

Kit Contents

1050340-PFF			
P551315	1500368	1500371	1500369
			
	Filter Head Adapter (yellow zinc plated) Qty: 1	Bolt 1/4" X 3.5"L Qty: 2	
	1500370		
			
Fuel Filter 3 mic Qty: 1	Oring -021 Qty: 1	Filter Head Qty: 1	

1050340-WSP			
P550550	1500363	1500371	1500369
			
	Adapter (Clear Zinc Plated) Qty: 1	Bolt 1/4" X 3.5" Qty: 2	
	1500370		
			
Fuel Filter (water separator) 20 mic Qty: 1	Oring -021 Qty: 1	Filter Head Qty: 1	

Required Tools

- 3/16" Allen wrench
- 1" Combination wrench
- 5/16" Socket
- Hose Cutter
- 7/8" Combination wrench
- Utility Knife

Option 1 (Pump with fuel separator & fuel filter)

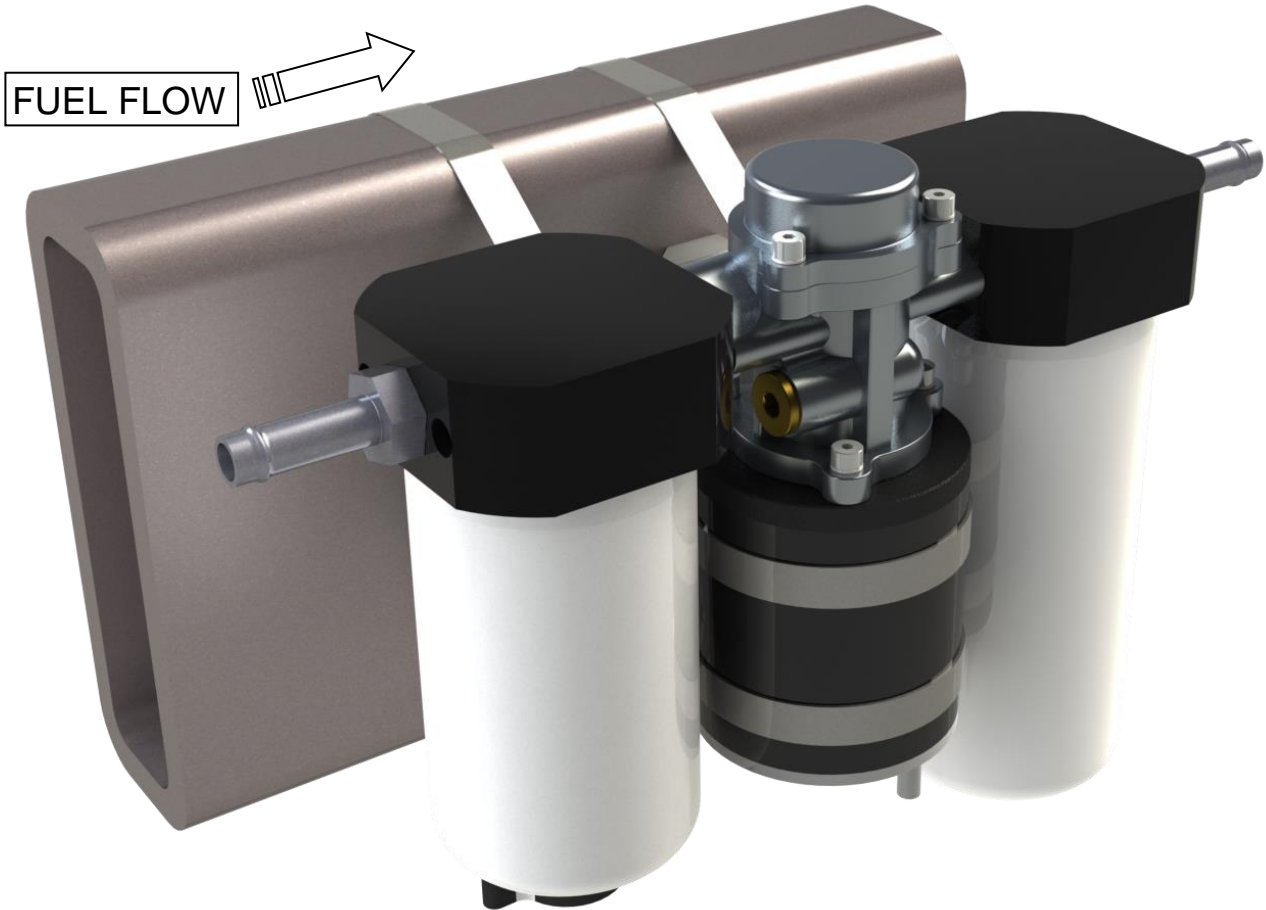

**Option 2
(Pump with fuel filter only)**

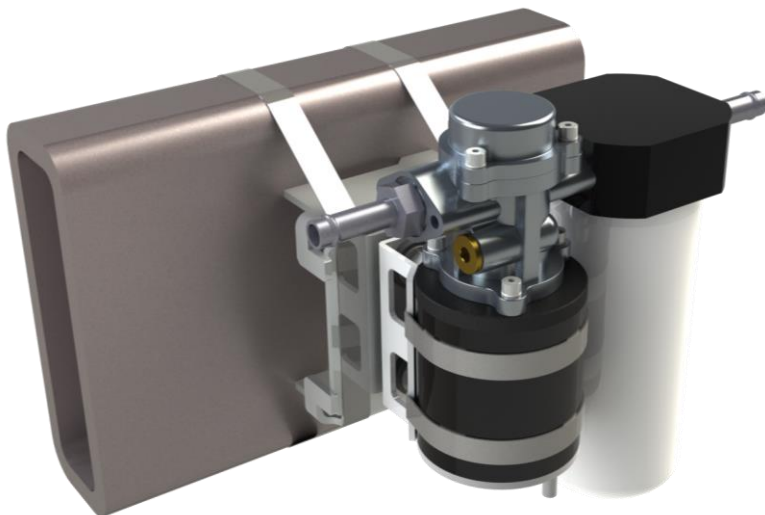

**Option 3
(Pump with water separator only)**



If Installing option 1 or option 3 the filter fitting screen will need to be removed by pulling it out with a set of pliers.



Installation

Pre-installation: If the flowmax pump is already mounted on the vehicle you will need to remove the barbed fittings before installing the filter head(s) to the pump. If the pump is not already mounted it may be preferred to assemble the filter head(s), Filter(s) and fitting(s) to the pump before mounting the assembly to the vehicle.

STEP 1 (SEE PAGE 3 FOR MOUNTING OPTIONS)

Option 1: With the Flomax pump already mounted on the vehicle with the band straps. Place orings into the orings groove and bolt on the filter heads (x2) to the pump using the supplied hardware and torque to 89 inch/pounds.

Option 2: With the Flomax pump already mounted on the vehicle with the band straps. Bolt on the filter head (x1) onto the (OUT) side of the pump using the supplied hardware and torque to 89 inch/pounds.

Option 3: With the Flomax pump already mounted on the vehicle with the band straps. Bolt on the filter head (x1) onto the (IN) side of the pump using the supplied hardware and torque to 89 inch/pounds.

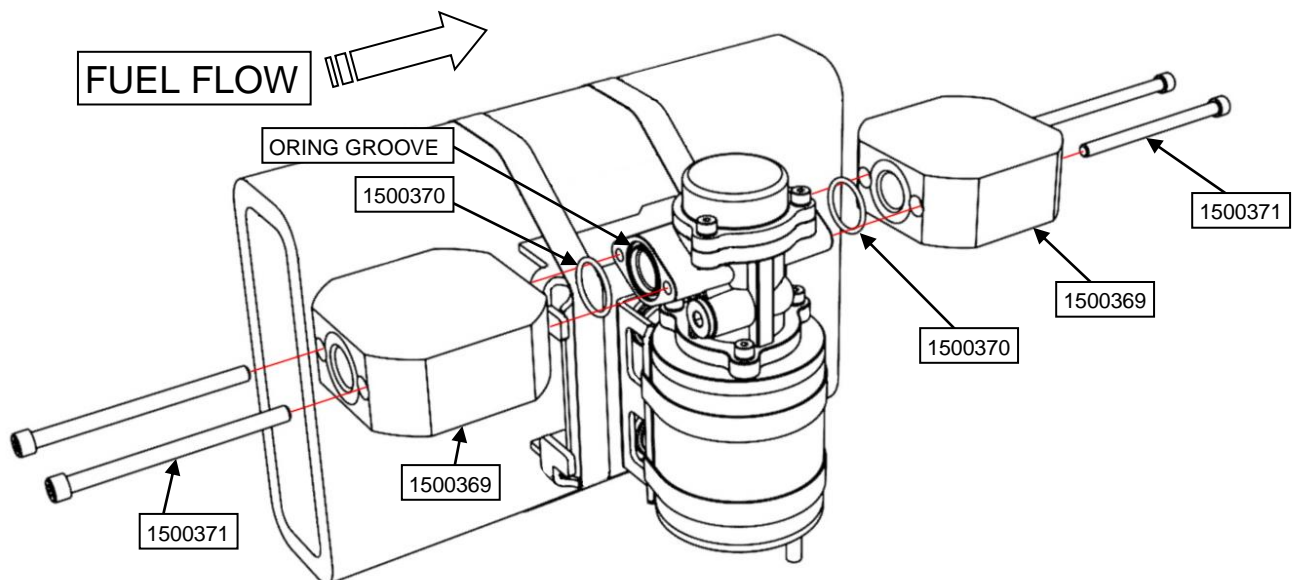

Fig. 1

STEP 2

Option 1: Apply Blue thread lock onto both adapters and insert the yellow zinc plated adapter into the filter head for the fuel filter. The other adapter threads into the filter head for the water separator. Insert barbed fittings into both filter heads.

Option 2: Apply Blue thread lock onto the supplied adapter and insert into the filter head for the fuel filter. Insert barbed fitting(s) into filter head and pump.

Option 3: Apply Blue thread lock onto the supplied adapter and insert into the water separator filter head. Insert barbed fitting(s) into filter head and pump.

NOTE: Use the supplied blue thread lock on the adapter(s) filter head side only, so they do not fall out with the next filter change.

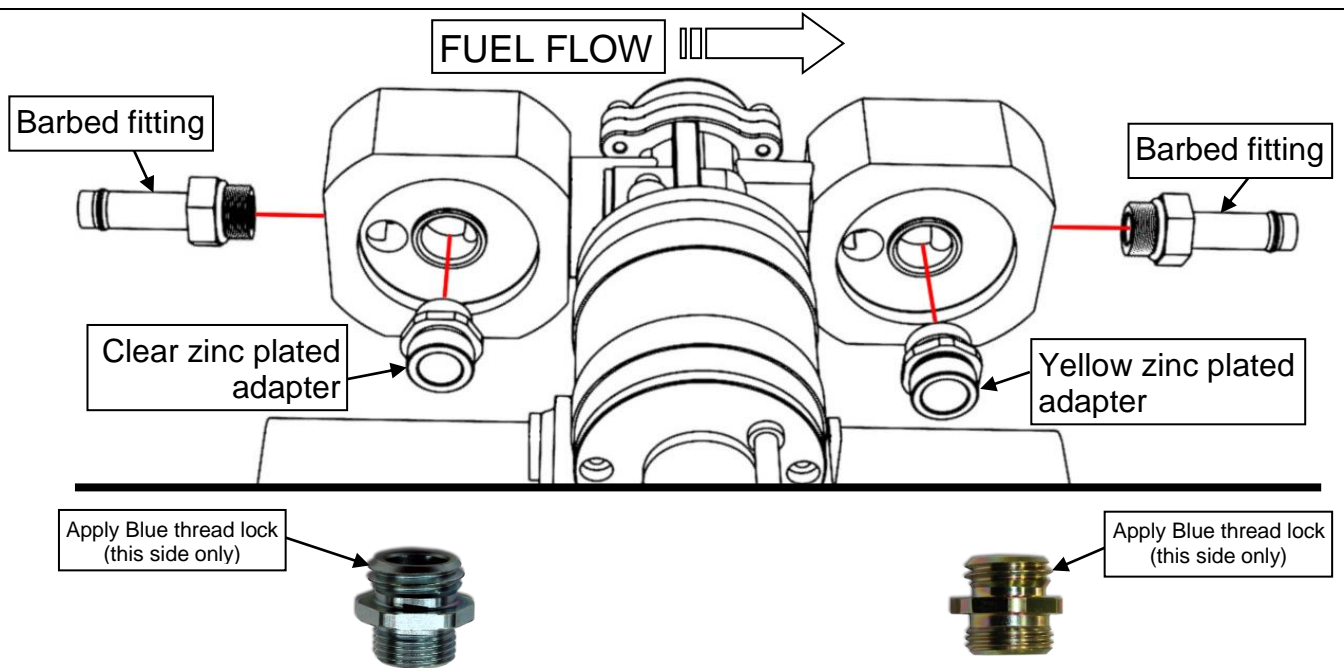

Fig. 2

STEP 3**(PREFILL BOTH FILTERS WITH CLEAN FUEL BEFORE INSTALLATION)**

Option 1: Lube the seals and spin on the water separator and the Fuel filter 2/3 to 3/4 of a turn once the seal touches.

Option 2: Lube the seal and spin on the Fuel filter 2/3 to 3/4 of a turn once the seal touches.

Option 3: Lube the seal and spin on the water separator 2/3 to 3/4 of a turn once the seal touches.

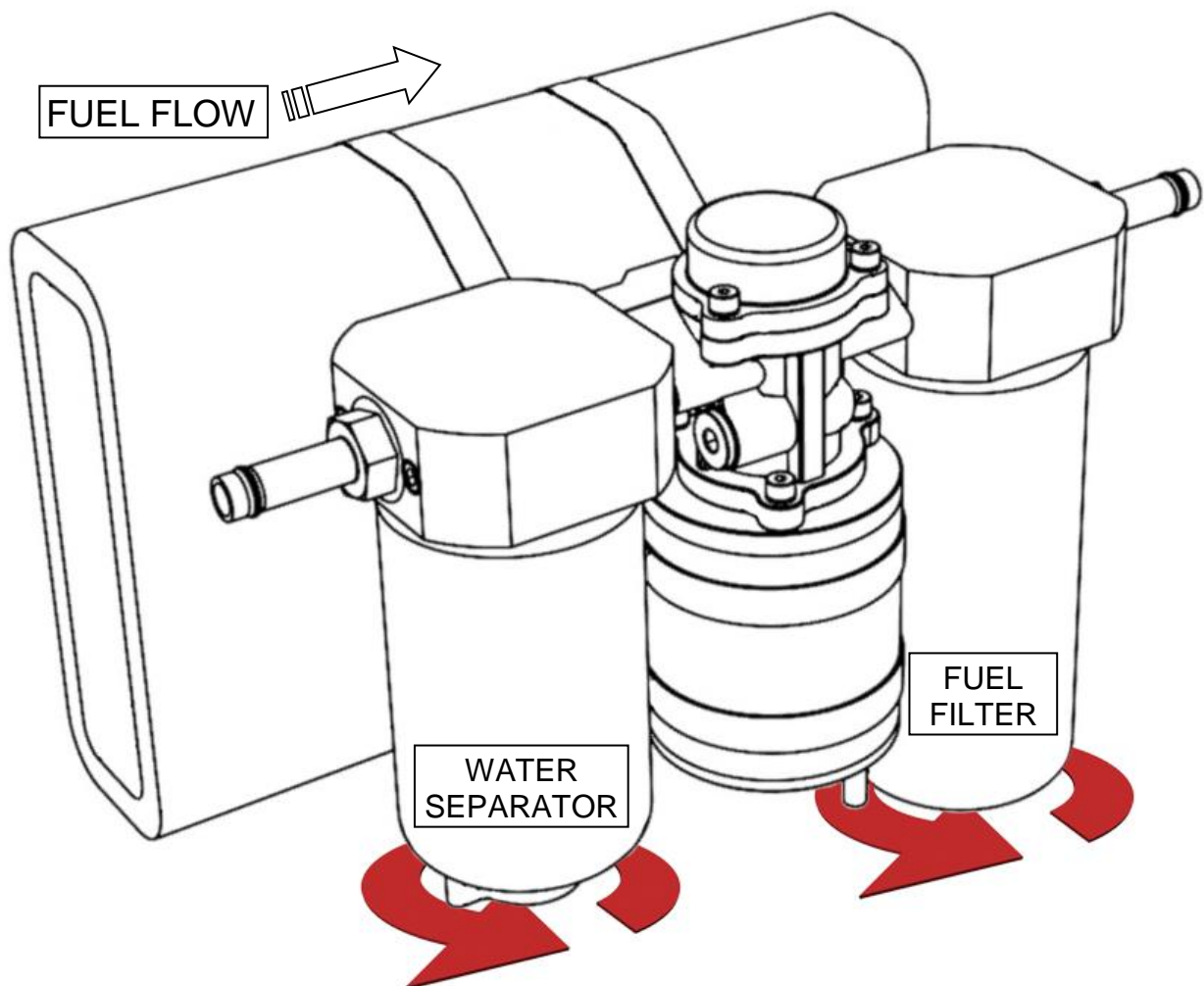

Fig. 3