

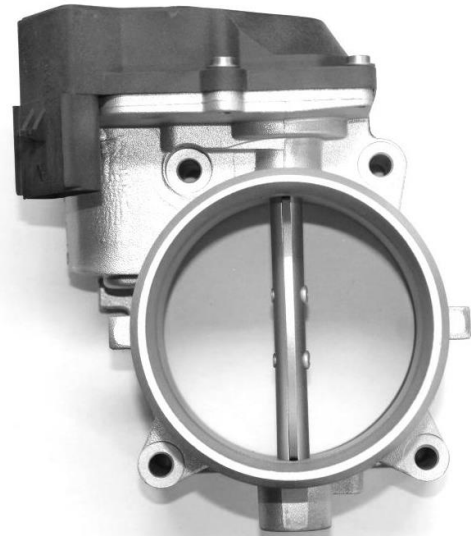

INSTALL MANUALS



ELECTRONIC POSITIVE AIR SHUTOFF





1036750	2007-2009 Dodge 6.7L
1036751	2010-2019 Dodge 6.7L
1036752	2014-2018 Dodge 3.0L
1036753	2019 Dodge 6.7L
1036754	2008-2010 Ford 6.4L
1036755	2011-2019 Ford 6.7L
1036756	2019 Ford 3.0L
1036758	2008-2010 GMC 6.6L (LMM/LGH)
1036759	2011-2016 GMC 6.6L* (LML)
1036760	2016-2018 GMC 2.8L (LWN)
1036761	2017-2018 GMC 6.6L (L5P)



*2011-2015 Savana/Express vans use 1036758

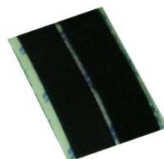

An Information decal has been provided in this kit. This may allow safety personal and inspector's to quickly identify that your vehicle is equipped with a BD Positive Air Shut Down unit. Install this decal in a visible location on the inside glass of the vehicle.

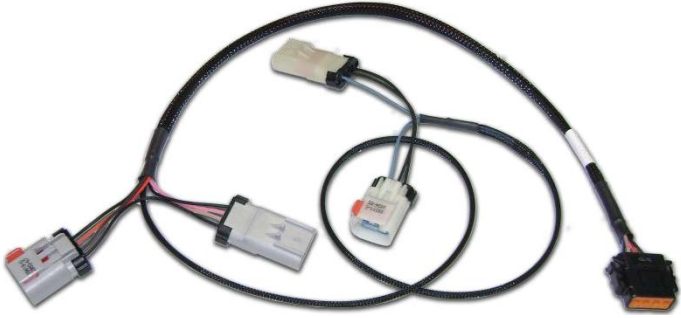

KIT CONTENTS

Please check to make sure that you have all the parts listed in this kit **before** you start the disassembly of your truck.



103675X Kit Contents			
1306731		1302380	
			
<i>Electronic Module</i>		<i>Switch Harness</i>	
Qty: 1		Qty: 1	
1302251	1306790	1302250-RG	2000108
			
<i>Switch Decal</i>	<i>Switch Guard Decal</i>	<i>Switch Guard</i>	<i>Switch Bracket</i>
Qty: 1	Qty: 1	Qty: 1	Qty: 1
1330052	1300131	1800060	1006701
			
<i>Bracket Screws</i>	<i>Cable Tie</i>	<i>Velcro strips (4")</i>	<i>Window Decal</i>
Qty: 2	Qty: 12	Qty: 2	Qty: 1

1036750	1036751
1302381	1302382
 A black automotive harness with several connectors, including a large multi-pin connector on the left and a smaller one on the right, with various colored wires (red, blue, green, yellow) connecting them.	 A black automotive harness with multiple connectors, including a large multi-pin connector on the left and several smaller connectors on the right, with various colored wires (red, blue, green, yellow) connecting them.
<i>Dodge 2007-09 6.7L Harness</i>	<i>Dodge 2010-18 6.7L Harness</i>
Qty: 1	Qty: 1

1036752	1036753
1302383	1302384
 A black automotive harness with several connectors, including a large multi-pin connector on the left and several smaller connectors on the right, with various colored wires (red, blue, green, yellow) connecting them.	 A black automotive harness with multiple connectors, including a large multi-pin connector on the left and several smaller connectors on the right, with various colored wires (red, blue, green, yellow) connecting them.
<i>Dodge 2014-19 3.0L Harness</i>	<i>Dodge 2019 6.7L Harness</i>
Qty: 1	Qty: 1

1036754	1036755
1302388	1302389
 A black automotive harness with multiple connectors, including a large multi-pin connector and several smaller ones, arranged in a loop.	 A black automotive harness with several connectors, including a large multi-pin connector and a smaller one, arranged in a loop.
<i>Ford 2008-10 6.4L Harness</i>	<i>Ford 2011-19 6.7L Harness</i>
Qty: 1	Qty: 1

1036756	
1302391	
 A black automotive harness with several connectors, including a large multi-pin connector and several smaller ones, arranged in a loop.	
<i>Ford 2019 3.0L Harness</i>	
Qty: 1	

1036758	1036759
1302385	1302386
 A black automotive harness with multiple connectors, including a large multi-pin connector and several smaller ones, coiled together.	 A black automotive harness with several connectors, including a large multi-pin connector and smaller ones, coiled together.
<i>GM 2008-10 6.6L Harness</i>	<i>GM 2011-16 6.6L Harness</i>
Qty: 1	Qty: 1

1036760	1036761
1302387	1302390
 A black automotive harness with several connectors, including a large multi-pin connector and smaller ones, coiled together.	 A black automotive harness with several connectors, including a large multi-pin connector and smaller ones, coiled together.
<i>GM 2016-2018 2.8L Harness</i>	<i>GM 2017-18 6.6L Harness</i>
Qty: 1	Qty: 1

TABLE OF CONTENTS

KIT CONTENTS	2
TABLE OF CONTENTS	6
Before you start	7
Required tools	7
Installation	8
Intake valve locations	8
2007-2019 Dodge 6.7	8
2014-2019 Dodge 3.0	9
2008-2010 GMC 6.6.....	10
2011-2016 GMC 6.6.....	10
2016-2018 GMC 2.8L.....	11
2017-2018 GMC 6.6L.....	12
2008-2010 Ford 6.4.....	13
2011-2019 Ford 6.7.....	13
2019 Ford 3.0.....	14
Crankshaft position sensor locations	15
2007-2019 Dodge 6.7	15
2014-2019 Dodge 3.0	15
2008-2016 GMC 6.6.....	16
2016-2018 GMC 2.8L.....	16
2017-2018 GMC 6.6L.....	17
2008-2010 Ford 6.4.....	17
2011-2019 Ford 6.7.....	18
2019 Ford 3.0.....	19
Module Mounting Locations	20
2007-2019 Dodge	20
2008-2018 GMC.....	21
2008-2019 Ford 6.7L.....	21
2019 Ford 3.0L.....	22
Electronic PAS system operation.....	25
Troubleshooting	26
Circuit board switch and LED functions.....	28
Wiring diagram	29

Introduction

Most late model diesel engines incorporate an electronic throttle body into the intake manifold to partially restrict intake air to aid in EGR function and meet ever increasing emission standards. When controlled correctly, this valve can completely shut off the outside air supply to stop the engine. The BD Electronic Positive Air Shutdown kit connects to this valve to shut the engine down in emergency situations.

The BD Electronic PAS will automatically shut off the engine if it exceeds a preset engine RPM or if toggled manually with the supplied switch. The BD module also has an automatic reset feature which will reopen the valve once the engine has stopped. No longer does the operator need to open the hood to reset the valve after a system test.

The BD Electronic PAS is easier to install than previous PAS products as it is completely plug and play with existing parts on the vehicle.

NOTE 2017+ GM 6.6L Duramax WILL set an engine fault code when the E-PAS is triggered. This is normal on this engine with any PAS system on this vehicle. Code should be cleared after a shutdown event but is not harmful.

Before you start

Ensure the intake valve on the vehicle will connect to the harness supplied with your kit, the connector may be different based on the year of manufacture of the vehicle and care must be taken to ensure the correct kit is ordered.

Required tools

- Drill
- 1/8" Drill Bit
- 1/2" Unibit
- Battery Terminal Wrench

Installation



VEHICLE SHOULD BE SAFELY SECURED BEFORE INSTALLATION.

1. Locate the intake air valve on the motor and connect the supplied BD PAS wiring harness inline by connecting the BD harness directly to the valve and to the vehicles original electrical connector.

NOTE: If the vehicle has been re-tuned to no longer utilize the intake air valve and it is currently disconnected, connect the BD harness only to the intake valve and leave the OE connector disconnected.

Intake valve locations

2007-2019 Dodge 6.7

Intake horn, pointing downwards on the driver side of the engine. The electrical connector is on the bottom of the valve. 2007-2009 have a 4 pin gray connector; 2010-2019 have a 5 pin black connector.

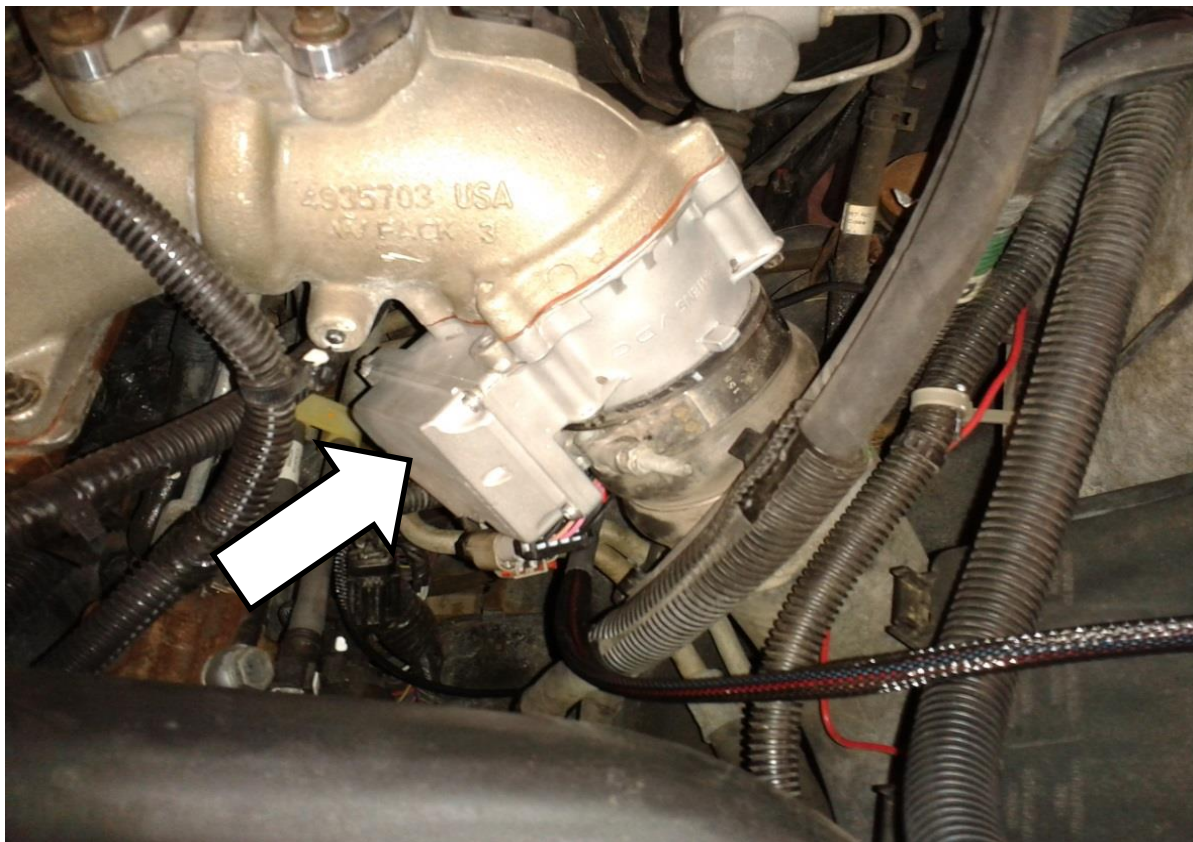

2014-2019 Dodge 3.0

Center top of engine on lower side of intake valve. Remove plastic engine cover, remove the charge air hose (spring clip), remove charge air hose adapter (4 x 8mm bolts) and move out of the way. The connector is orange colored.

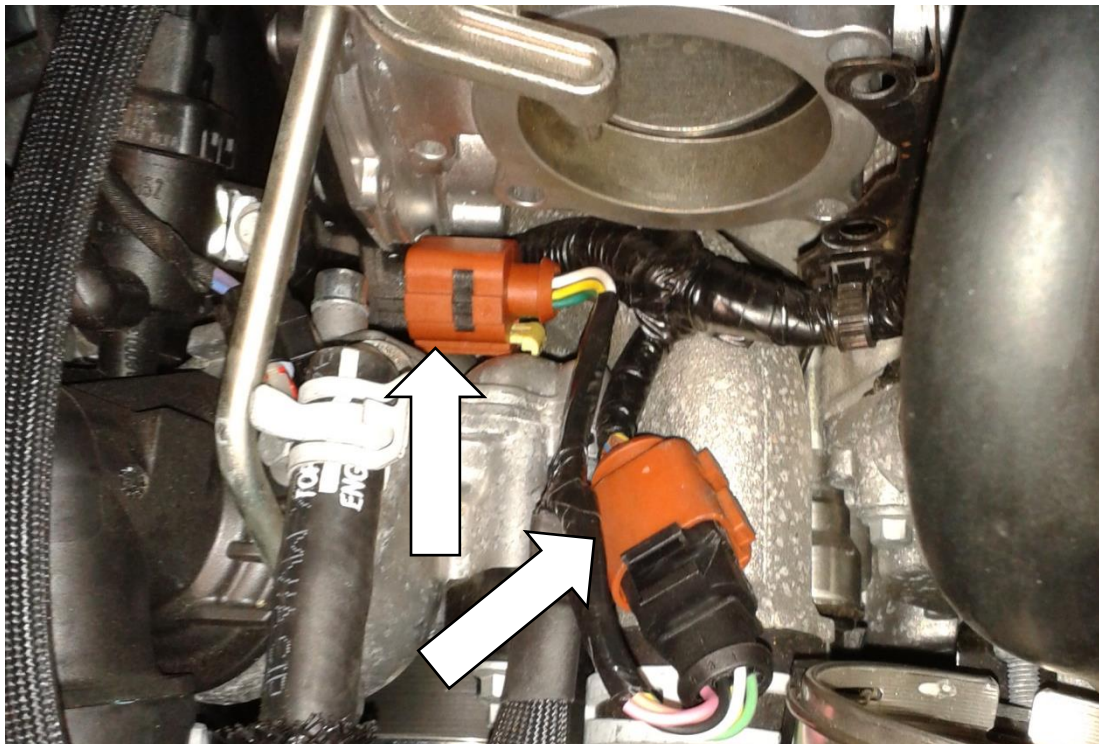
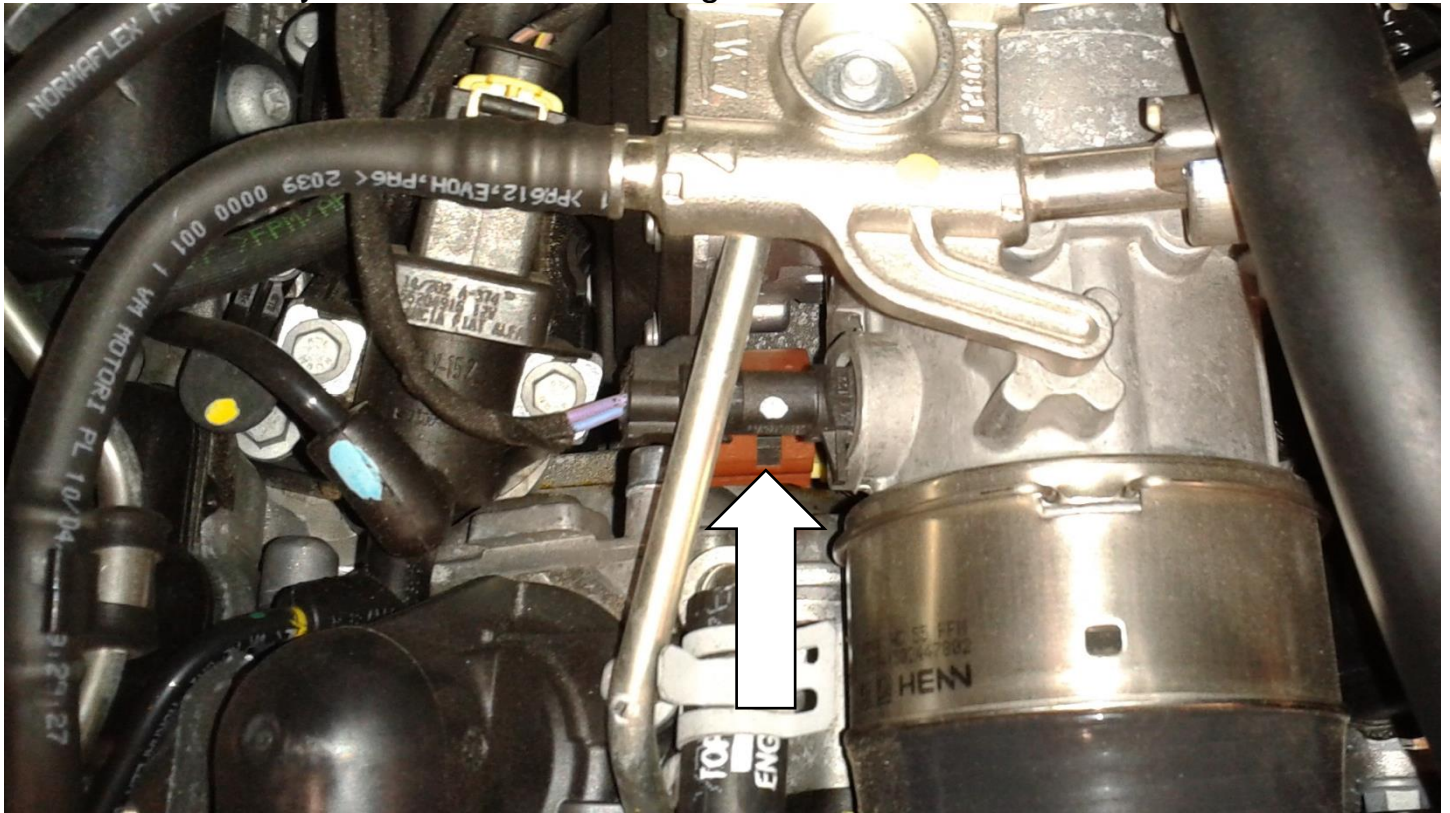

2008-2010 GMC 6.6

Passenger side of engine, between the air box and the alternator. The electrical connector is on the bottom of the valve.

NOTE: Removing the air intake tube between the air box and engine makes for easier access to the valves electrical connector.

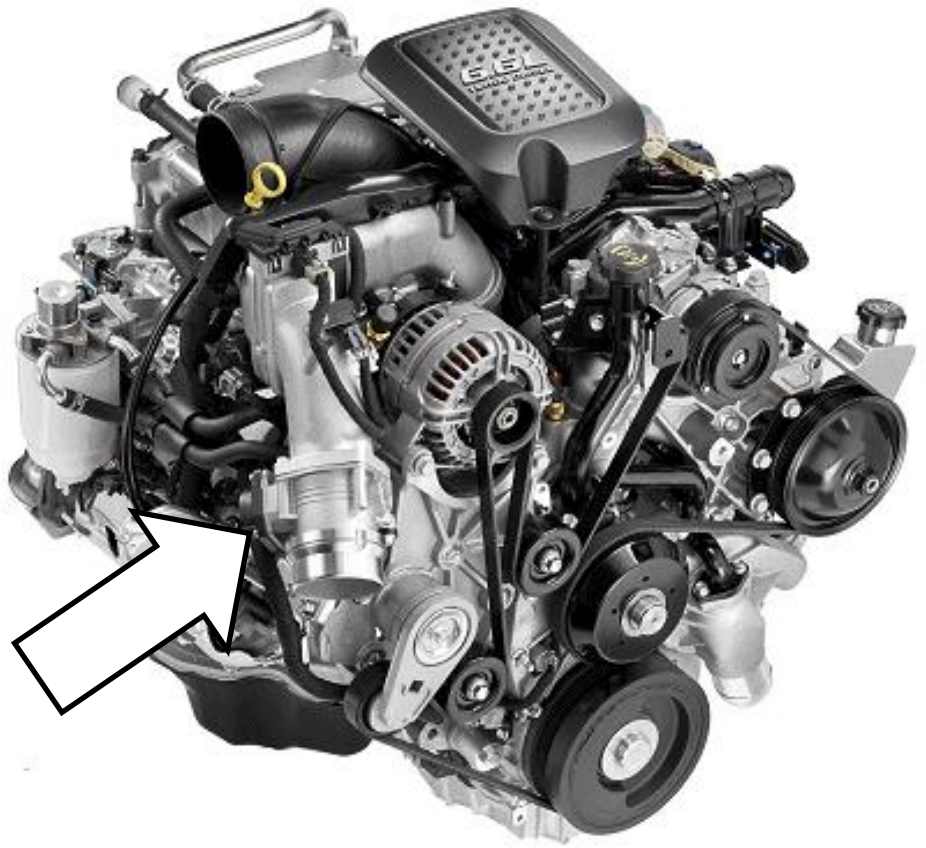

2011-2016 GMC 6.6

Passenger top side of engine. The electrical connector faces the front of the vehicle.

NOTE The red connector lock tab must be engaged or connector may come apart from the BD harness.

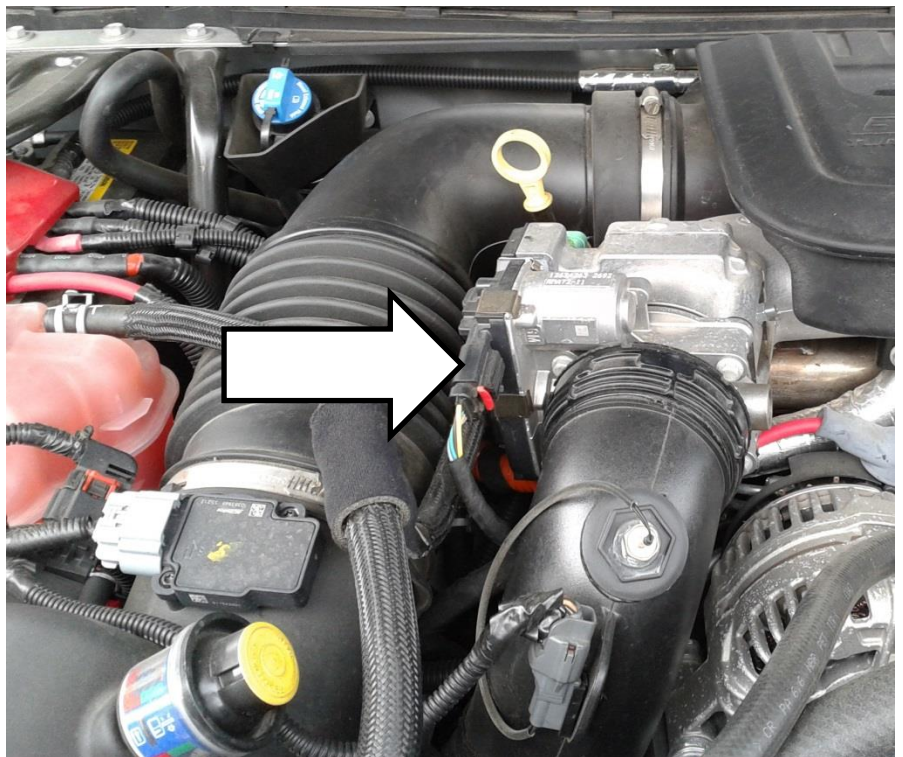

2016-2018 GMC 2.8L

Top of engine, driver's side. Removing the plastic engine cover will grant better access. Electrical connector location indicated by arrow.

NOTE Ensure the OE harness lock tab is engaged or the connector may come apart from the BD harness



2017-2018 GMC 6.6L

Passenger side below the intake air tube. Remove the intake tube by loosening the two hose clamps. The electrical connector is then easily accessible.

NOTE Ensure the gray lock tab is engaged on this connection or the connector may come apart from the BD harness.

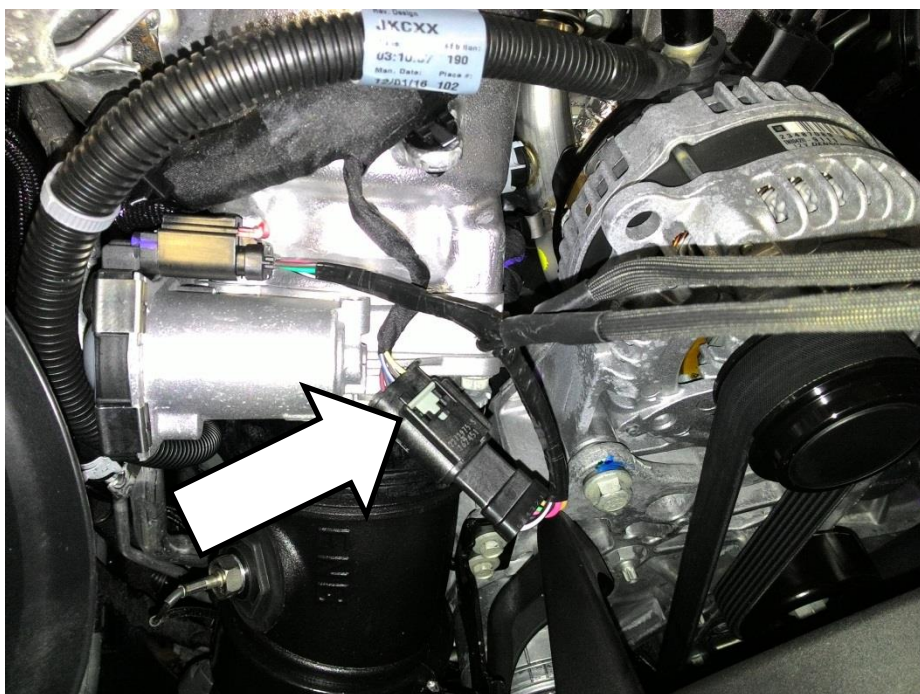
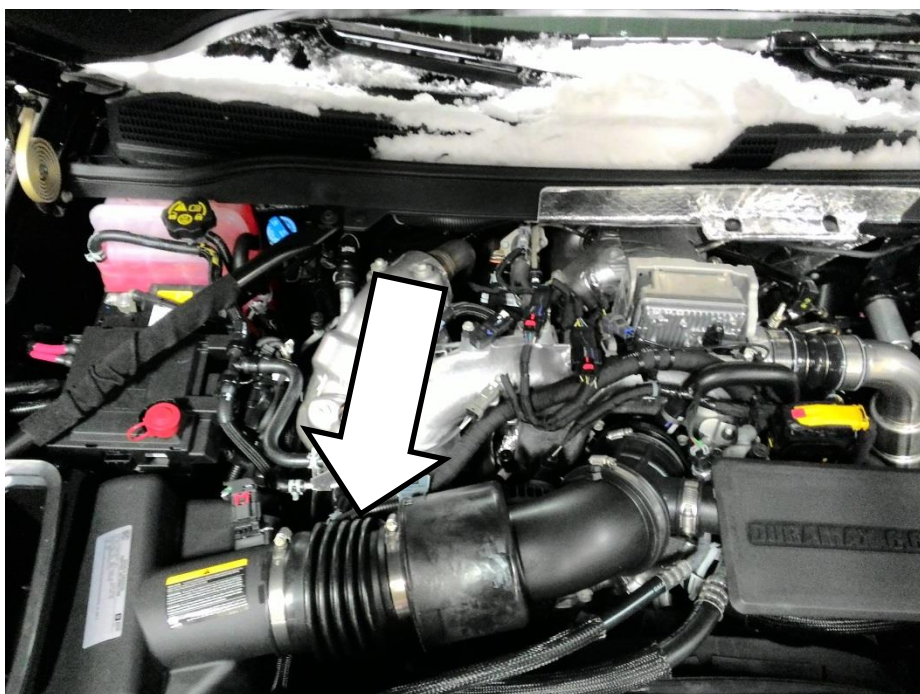

2008-2010 Ford 6.4

Front top of engine, behind the radiator fan shroud. The electrical connector is located on the back side of the valve.

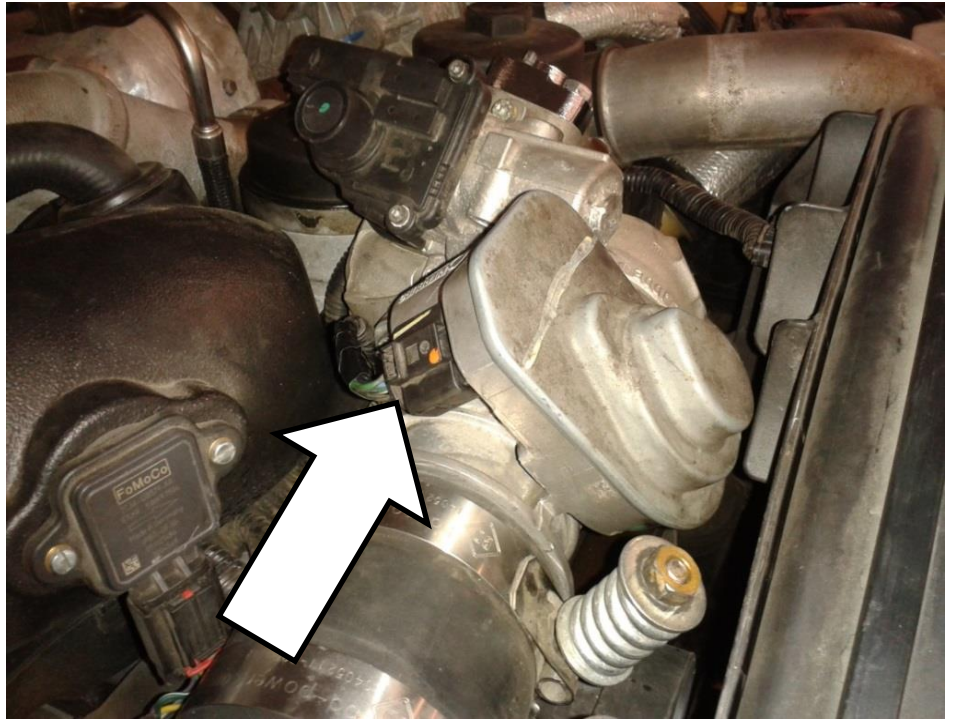

2011-2019 Ford 6.7

Front top of engine, behind the radiator fan shroud. The light brown electrical connector is located on the bottom front side of the valve.

NOTE: Removing the plastic charge air tube from the valve makes for easier access to the valves electrical connector.

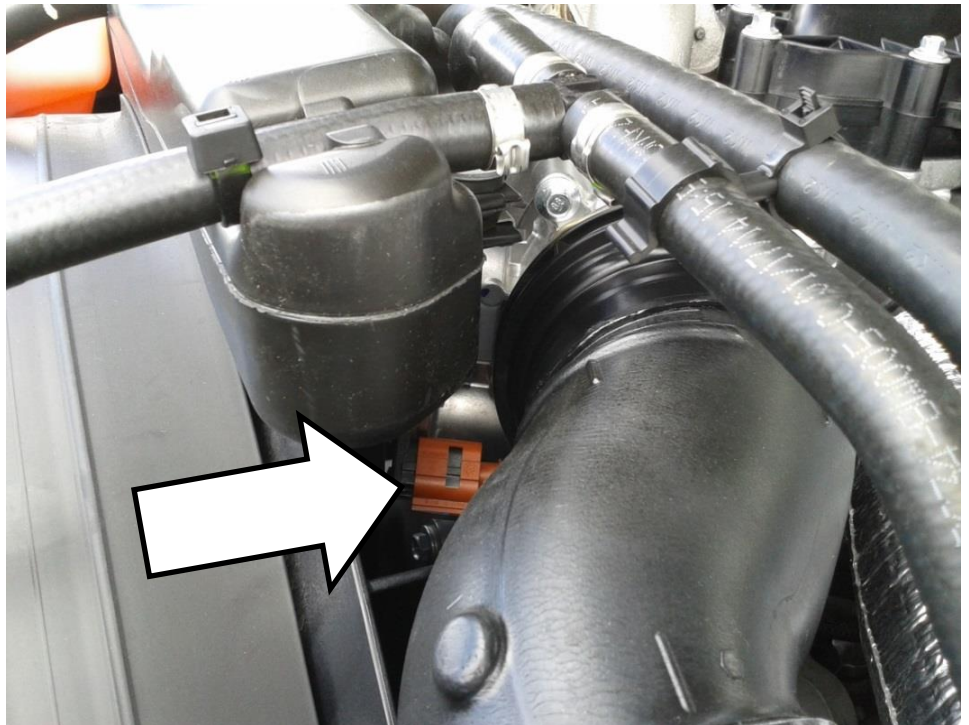

2019 Ford 3.0

Front top of engine below the air intake pipe.

NOTE The red connector lock tab must be engaged or connector may come apart from the BD harness.

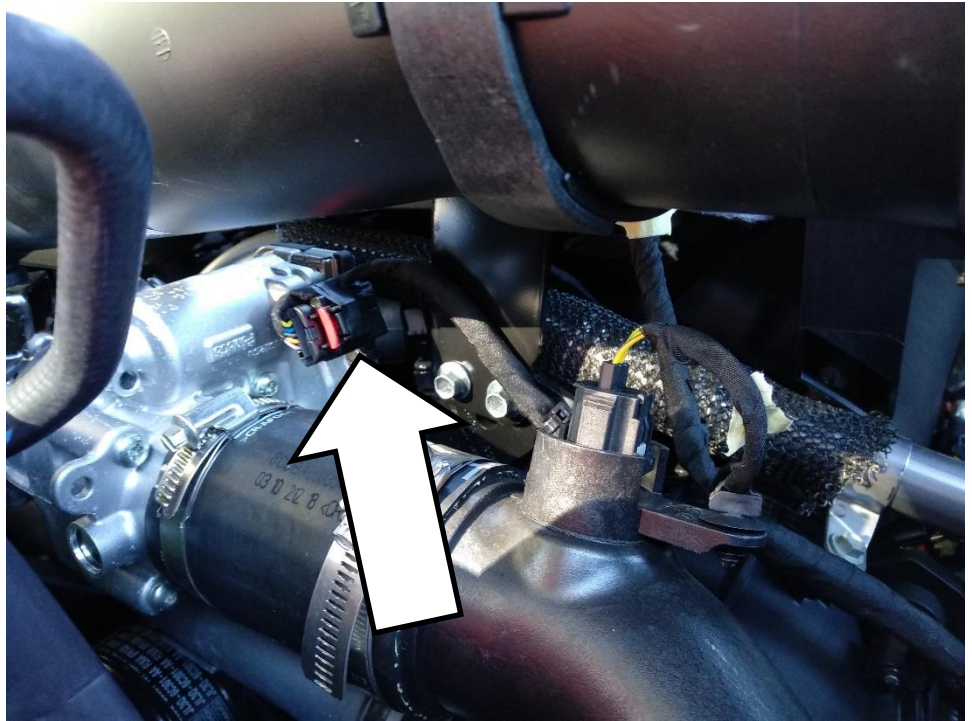

2. Locate engine crankshaft position sensor on the motor. Connect the supplied BD PAS wiring harness inline so that the BD harness connects to the crankshaft position sensor and to the vehicles original wiring.

Crankshaft position sensor locations

2007-2019 Dodge 6.7

Driver side of engine just behind crankshaft drive belt pulley.

(Do not mistake for the camshaft position sensor located above)



2014-2019 Dodge 3.0

Bottom rear of engine, mounted on the driver side of the oil pan.

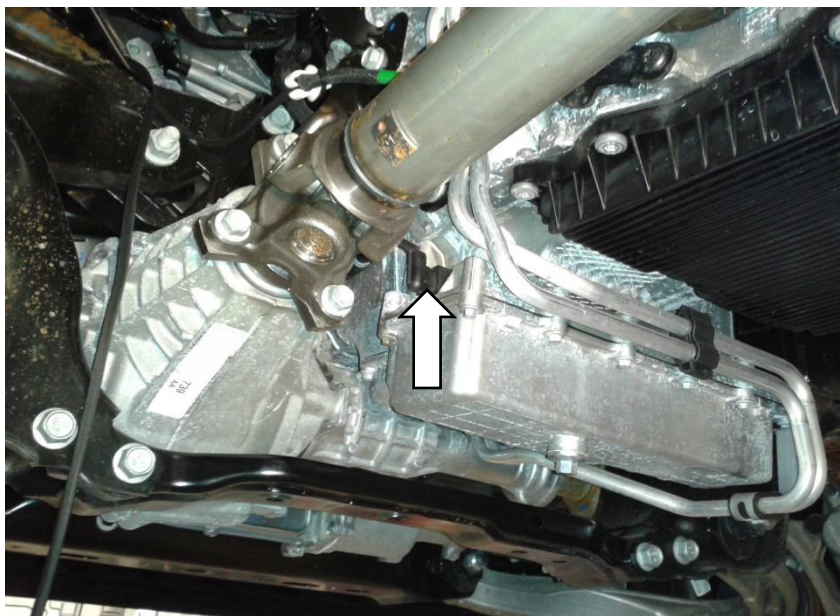

2008-2016 GMC 6.6

Passenger side of engine beside crankshaft drive belt pulley.

(Do not mistake for the camshaft position sensor located beside the water pump pulley)

**2016-2018 GMC 2.8L**

Lower driver side of engine, the electrical connector is mounted at the side of the oil pan.



2017-2018 GMC 6.6L

The crankshaft position sensor is not accessible on this engine as it is behind the starter motor. Instead, the BD harness plugs in to an inline harness connector at the top of the motor. This is the 8 pin connector.

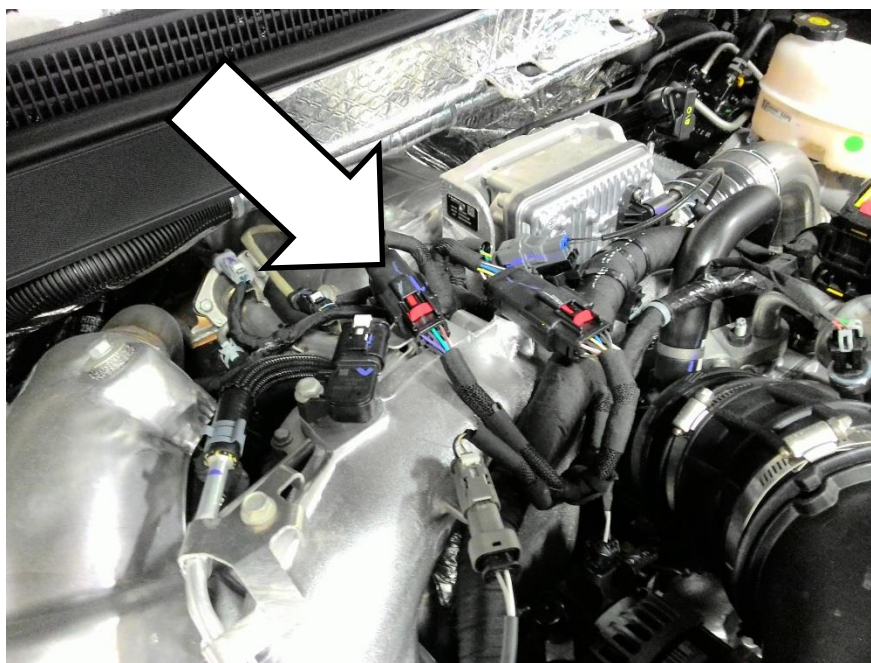

2008-2010 Ford 6.4

Passenger side of engine, bottom front. To gain better access, remove the bolt securing the passenger side of the upper steering stabilizer shock absorber and swing out of the way. A long-handled screw driver or similar tool can help push the connector off once released.

(Do not mistake for the camshaft position sensor on the opposite side of the block).



2011-2019 Ford 6.7

Driver side of engine block in transmission to engine adapter flange. Remove rubber plug from access hole to reach the electrical connector behind it.

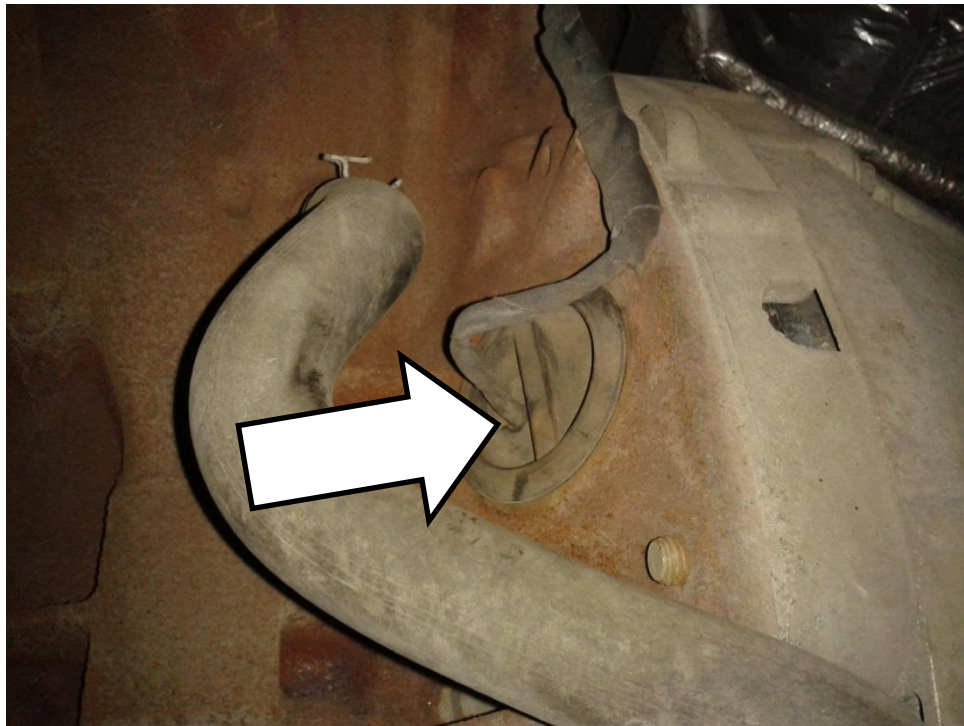

2019 Ford 3.0

Driver side rear of engine, clipped to the dipstick tube.

Use care when routing the BD wiring harness to keep it away from the exhaust manifold.

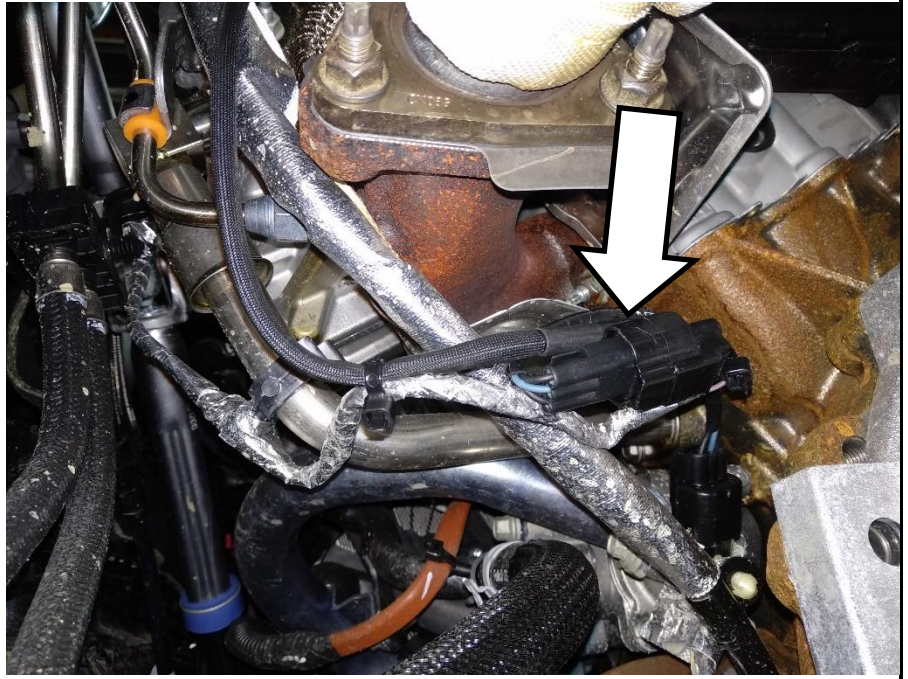

It is necessary to remove the rear belly pan to access the crankshaft position sensor. This is removed with four 8mm and one 11mm fastener.



3. Remove the toggle switch from the supplied switch harness. Route the end of the switch wiring harness from within the engine bay, through the driver's side of the firewall to below the dashboard. Suggested pass through location is through a slit in the existing grommet for the engine to instrument panel wiring harness, otherwise a new hole may be drilled and a new grommet installed if necessary.
4. Route the battery connection ring terminals to the driver side battery (2019 F150 use passenger side). Connect BLACK wire ring terminal to the driver side battery negative or to body ground if desired. Leave the RED positive wire disconnected until end of installation.
5. Locate suitable location for BD PAS module so that it will reach both wiring harnesses. Attach it with supplied adhesive hook and loop tape or wire ties. Suggested mounting location is on top of the plastic fuse box cover on the driver side of the engine bay. If using hook and loop tape, thoroughly clean the mounting surface for good adhesion.

Module Mounting Locations

2007-2019 Dodge Driver side front corner fuse box



2008-2018 GMC

Fuse box on driver side of the engine bay



2008-2019 Ford 6.7L

Driver side rear of the engine bay behind or beside the coolant bottle



2019 Ford 3.0L

Passenger side of engine bay, at fuse box location



6. Carefully secure all wiring within the engine bay with supplied wire ties to that it is away from moving parts, chafe hazards and heat sources. Use extra care with the crankshaft position sensor wiring due to the close proximity to belts, fans and road debris and potential consequences of a short or break in this wire.
7. Inside the cab, reconnect the toggle switch to the switch wiring harness in the same way they were removed. See below for reference. Double check the connections here as wiring the toggle switch incorrectly may damage the module.

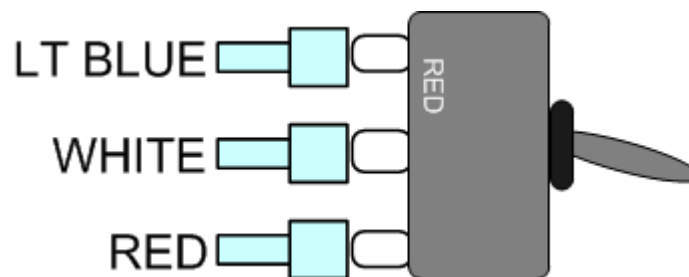

8. Locate suitable spot to mount switch on the dashboard within reach of the driver and in a highly visible location. Ensure there is sufficient space behind the dash to mount the switch. Drill a 1/8" pilot hole, then using a stepper bit (unibit) drill a 1/2" hole in the dashboard. Install switch with the groove in the thread boss facing down. Install with either the supplied switch decal or with the supplied switch guard and apply decal to the switch guard. Secure wire below the dashboard using supplied wire ties.
NOTE: A switch bracket has been supplied as an alternative for mounting the switch.

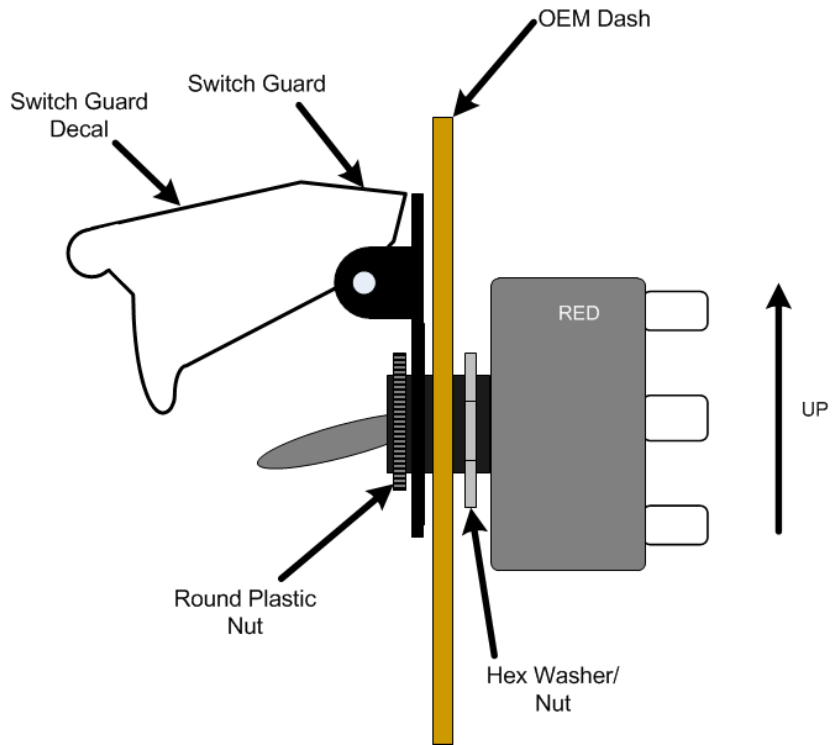

Switch decal



Switch Guard with decal applied.



9. Connect RED positive feed wire to the battery.
10. Test and verify system functionality. *Ford 6.7L read important note below first.*

Manual Activation Test: With the engine running at idle, momentarily toggle the PAS switch on the dashboard. The engine should stop within a few seconds. Wait at least 10 seconds before restart.

Automatic Activation Test: With engine not running, remove the cover from the module to access the circuit board. Keep away from metal objects that may cause a short circuit. Set the bottom switch to "1500 RPM TEST" mode. This will cause the module to shut the engine down if it exceeds 1500 RPM. Start the vehicle and slowly accelerate the engine, verify that it shuts down over 1500 RPM. Wait at least 10 seconds before restart.



NOTE: The BD E-PAS module is connected to constant battery power unless the harness fuse is removed. Use care when opening module to avoid short circuiting it against metal objects in engine bay.

IMPORTANT: *The Ford 6.7L trucks will set code P0069 if the EPAS is used to shut the truck off twice in a row. This is due to the factory programming and is not a problem specific to the BD EPAS. After the truck has run & been shut off normally twice in a row, this code will clear. If the engine light comes on; the code will need to be cleared with a scan tool.*

11. Set the operation mode switch on the circuit board back to AUTOMATIC and Set the automatic RPM shutdown speed on the module according to the engine it is installed with. This must be above the normal engine redline to avoid accidentally setting it off during driving. Reinstall module cover and re-secure module.



Year/Make	RPM
Dodge 6.7L	4200 RPM
GM 6.6L	4600 RPM
Ford 3.0L, 6.4L Dodge 3.0L	5000 RPM
Ford 6.7L	4600 RPM

Electronic PAS system operation

The BD Electronic PAS module constantly keeps track of engine speed and will automatically stop the engine if it exceeds the preset maximum RPM. The air valve can be shut at any time even if the engine is not running by toggling the switch on the dash manually.

When the engine is off, the BD E-PAS module will go into a low power consumption state and the toggle switch on the dash will not be lit. Once the engine is started, the module will automatically begin monitoring engine RPM and the toggle switch on the dash will light up to show the system is ready.

If the system is triggered automatically or manually by the switch, the intake air valve will close and remain closed until the engine RPM has dropped to zero and for an additional 5 seconds afterward. During this time the toggle switch will flash to indicate a closed valve position. **DO NOT ATTEMPT TO RESTART ENGINE WHILE VALVE IS CLOSED.** The valve will automatically reset itself to the open position and the toggle switch light will turn off once shutdown process is complete.

Ford 6.7 – Read important note in step 10

Troubleshooting

Valve does not close by manual toggle switch activation

No power to module. Check fuse at battery. If fuse is blown, inspect harnesses for short circuits or other problems. Remove cover from module and check that the POWER lamp is flashing every two seconds with engine off indicating it is powered and in standby.

Incorrect switch wiring. Carefully check the toggle switch wire connection is correct, incorrect connection may damage the module.

Intake air valve connectors not fully seated. An audible click should be heard when the connector is fully mated together. Tug on connector to ensure it does not come apart.

Valve closes by manual toggle, not automatically

Incorrect module mode setting. If conducting low speed system test, verify that the lower switch on the module circuit board is set to the middle position, "1500 RPM TEST". For normal automatic operation, the switch should be fully counter clockwise, "AUTOMATIC" and RPM selector switch is set to the correct speed.

Harness connected to camshaft position sensor rather than crankshaft position sensor. Verify against pictures in installation section of this manual.

No RPM signal to module. Open module cover and start engine. Verify that RPM light is flashing when engine is running and POWER light is on solid. If it is not on or is intermittent, carefully check blue wire from the modules black connector (pin 7) to the crankshaft position sensor is not severed.

<p>Engine light on / fault codes set</p>	<p>Code set during installation. If the ignition switch was on or ECM had not powered down during installation, fault codes may be set by disconnecting air valve. Clear codes and recheck.</p> <p>Intake air valve connectors not fully seated. An audible click should be heard when the connector is fully mated together. Tug on connector to ensure it does not come apart.</p> <p>Black connector disconnected from BD E-PAS module. If the module is not currently being used, the black connector must still be plugged into the module or the valve connected back to stock configuration.</p> <p>2017-2018 GM 6.6 <i>will</i> set a P0106 on every shutdown event. This is normal for this particular engine.</p>
<p>Engine does not start</p>	<p>Connectors not mated. Inspect crankshaft position sensor connector is correctly installed; an audible click should be heard when connected. Tug on connectors to verify they are correctly mated.</p> <p>Shorted crankshaft position sensor wire. Inspect the blue wire from the modules black connector (pin 7) to the crankshaft position sensor; if this wire is chaffed or broken it may short out the crankshaft position sensor signal.</p> <p>Intake air valve jammed shut or defective. Toggle the system manually while listening for valve movement. If suspect, remove the intake air tube from the valve and visually verify the intake air flap is not closed.</p>

Circuit board switch and LED functions

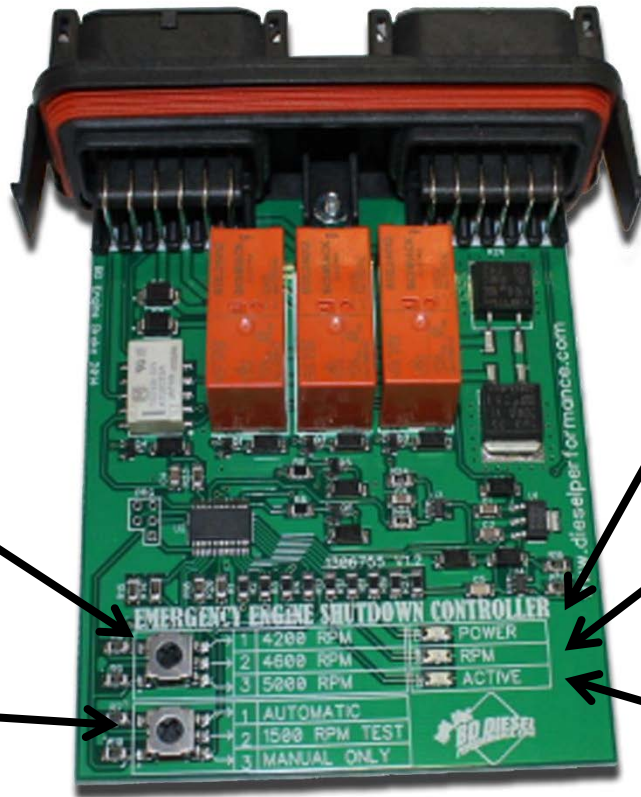

Maximum engine RPM for automatic mode

Operation Mode: Automatic, test or manual only.

Power light on when engine running. Flashes every 2 seconds when in standby.

RPM light flashes when the engine is running.

Active light on when the valve is controlled by the module.

EMERGENCY ENGINE SHUTDOWN CONTROLLER			
1	4200 RPM	POWER	
2	4600 RPM	RPM	
3	5000 RPM	ACTIVE	
1	AUTOMATIC		
2	1500 RPM TEST		
3	MANUAL ONLY		

Wiring diagram

