 **BCA**<sup>TM</sup>

**BEARINGS** by **NTN**



**OE Crosses the Line Into the Aftermarket**



# This is BCA<sup>®</sup>

## Over a century of experience

Bearing Corporation of America (BCA), founded in Lancaster, Pennsylvania in 1897, has been providing bearing solutions to our customers for over a century. BCA got its start manufacturing precision-engineered bearings for the emerging auto & truck industries before becoming a supplier to leading OEMs. NTN purchased BCA in 1996 and it is now a global manufacturer of wheel hub assemblies and bearings.

## A global company with local manufacturing

NTN has 76 plants, 14 R&D centers and more than 25,000 employees worldwide. Founded in 1918, NTN brings over 100 years of premium quality to our name.

Our Elgin, Illinois plant provides automotive aftermarket customers with highly-engineered replacement parts that meet or exceed OE engineering expectations. The state-of-the-art 670,000 square foot facility is one of the largest manufacturers of hub assemblies in the world, fulfilling more than 30% of the North American OE vehicle production demand, nearly twice as much as our closest competitor.

This unparalleled ability to meet demand makes us the #1 supplier of OE-engineered hub assemblies.

The majority of our loose and tapered bearings are produced in one of two plants; Hamilton, Alabama or Macomb, Illinois. NTN's Hamilton plant produces high-capacity roller bearings, as well as some of the largest bearings in the world, and our Macomb plant is one of the largest manufacturers of precision roller bearings in North America.

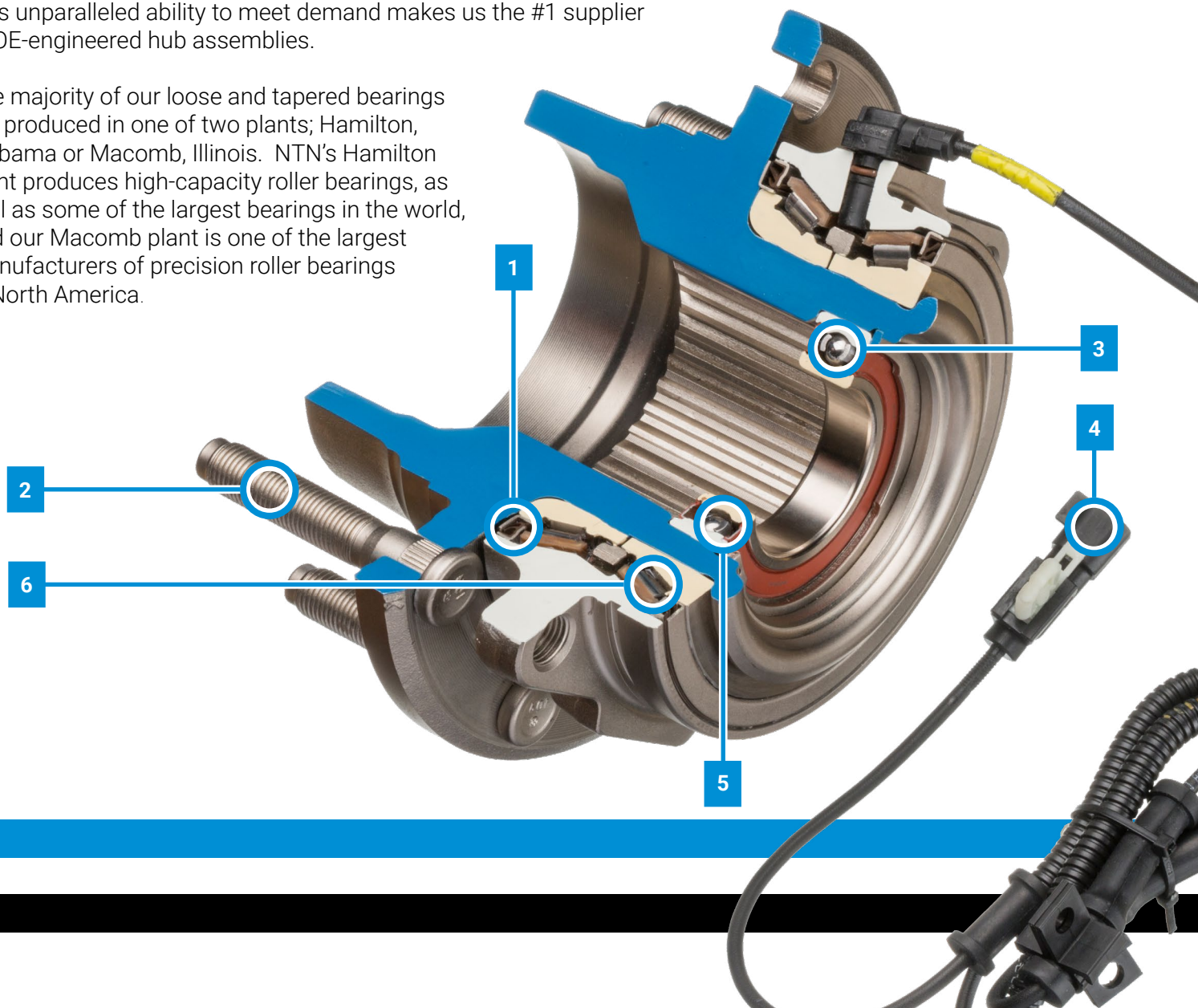

# Wheel Hub Assemblies

**Get the job done right the first time - avoid comebacks, warranty claims and turn your bays**

Quality is embedded in both our commitment to the latest technological advancements and our design philosophy of performance. BCA delivers Gen 1, Gen 2 and Gen 3 hub assemblies featuring exceptional fit, durability and performance for longer life.

## Gen 3 Wheel Hub Features and Benefits

### 1. CUSTOM-DESIGNED SEALS

All BCA applications that require ABS functionality utilize our custom-designed seals that are molded over with magnetic encoders to ensure proper ABS operation

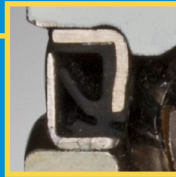

### 2. PREMIUM WHEEL STUDS

Forged-steel construction provides the toughness and durability required for even the harshest applications



### 3. PRECISION CAGE DESIGN

Rolling element cages reduce friction by keeping rolling elements spaced correctly, preventing damage and resulting in reduced operational temperatures



### 4. OE-STYLE ABS PLUGS

Application-specific components to ensure proper connection and performance of the ABS module and sensors



### 5. PREMIUM GREASE

Pre-lubricated bearings packed with specialized grease provide longer life and a wider range of operational temperatures

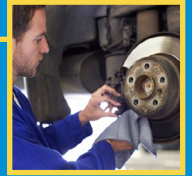

### 6. WORLD-CLASS ENGINEERING

Application-specific engineering design reduces noise, vibration and harshness (NVH), helping to avoid unnecessary comebacks



# Gen 2 Wheel Hub Features and Benefits

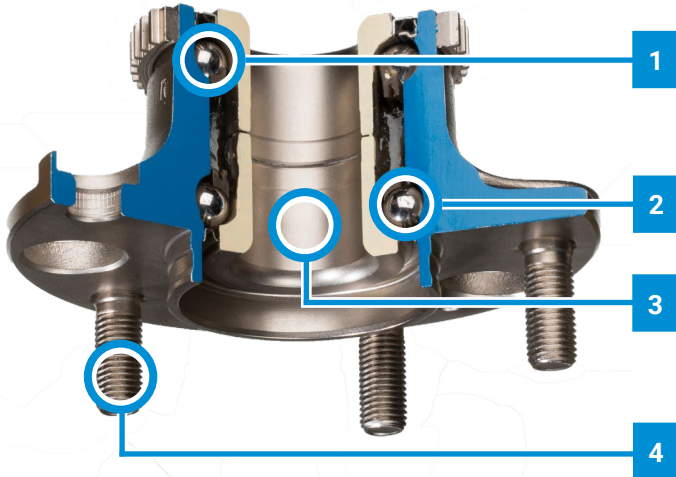

## 1. PRECISION GROUND & POLISHED ROLLERS & RACEWAYS

Ensure low friction, smooth performance, even load distribution and extended bearing life



## 2. PREMIUM GREASE

Pre-lubricated bearings packed with specialized grease provide longer life and a wider range of operational temperatures



## 3. HIGH-GRADE STEEL

Yields excellent hardness qualities to maximize resistance against deformation and wear



## 4. PREMIUM WHEEL STUDS

Forged-steel construction provides the toughness and durability required for even the harshest applications



# Gen 1 Wheel Hub Features and Benefits

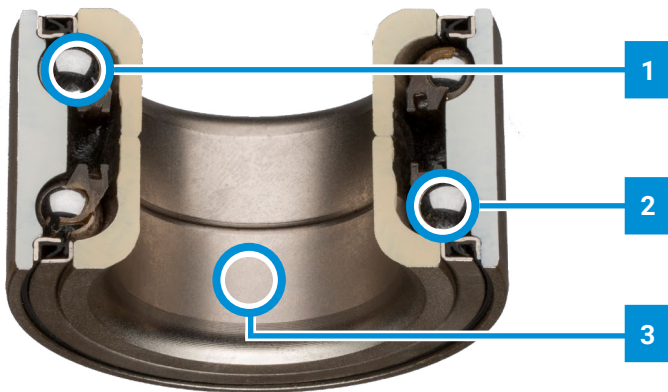

## 1. PRECISION GROUND & POLISHED ROLLERS & RACEWAYS

Ensure low friction, smooth performance, even load distribution and extended bearing life



## 2. PREMIUM GREASE

Pre-lubricated bearings packed with specialized grease provide longer life and a wider range of operational temperatures



## 3. HIGH-GRADE STEEL

Yields excellent hardness qualities to maximize resistance against deformation and wear



# Confidence. Driven by BCA.

## BCA is committed to delivering premium products you can rely on.

We recognize that using OE-quality parts are integral to maintaining the intended level of performance and, more importantly, the safety of the vehicle. NTN's automotive facility includes an in-house testing lab that performs stringent OE testing, as well as our own propriety tests, to ensure our parts maintain safety and performance standards, even in the harshest conditions.

### Our Testing Capabilities include:

- Fatigue
- Strength & rigidity
- NVH
- Seal durability
- Rotational torque
- Functional tests
- Impact
- Environmental exposure

The chart to the right shows the results of a test performed on a BCA Gen 3 Wheel Hub in comparison to two of our competitors' products.

### Explanation of Bearing Life Test

The NTN test lab conducted a 0.8G overturning moment test on three wheel bearings. This test subjected the wheel bearings to 0.8Gs of lateral acceleration, while in rotation, to simulate extreme cornering. To put this in perspective, if you were in an SUV and took a turn fast enough to generate 0.8Gs of lateral acceleration, the vehicle would most likely roll over. After testing, the bearings were disassembled and inspected for failures. The competitive aftermarket bearings experienced raceway flaking damage as well as ball and cage failures, while BCA's bearing survived over 60 hours with no evidence of damage or excessive wear.

### Bearing Life Test

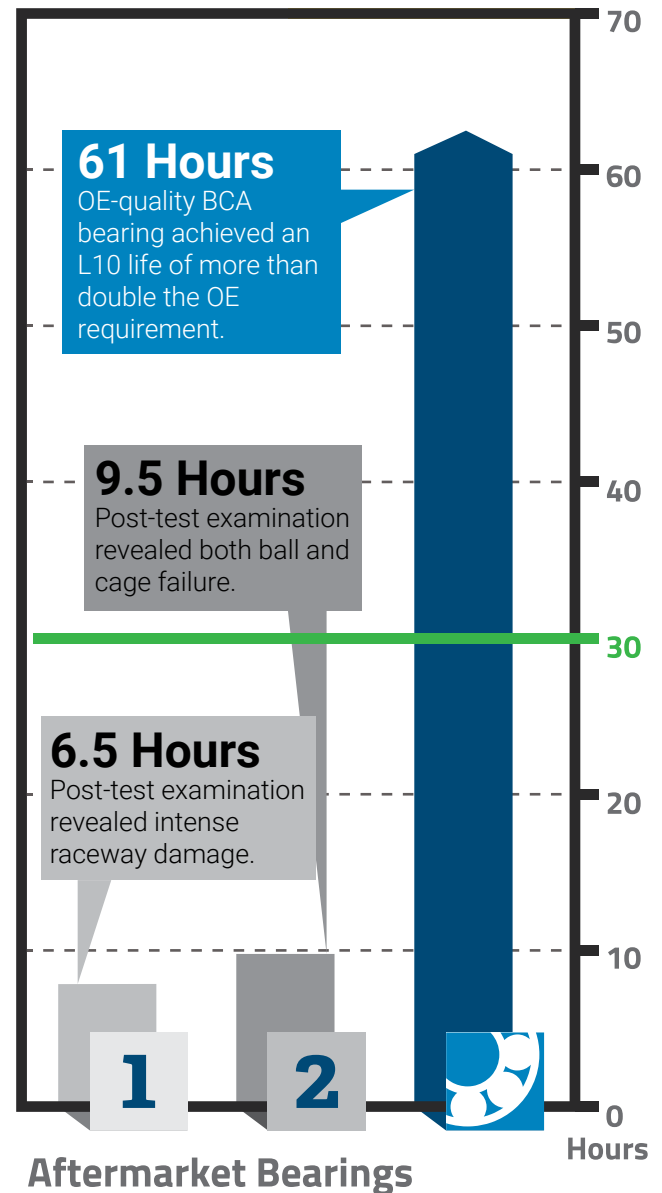

OE specification = L10 criteria of 30 hours.

SOURCE: Test conducted by NTN Bearing Corporation of America

# Bearings

## BCA is your complete aftermarket partner.

BCA knows that you need bearings for a breadth of applications, and not just for automotive. Our comprehensive premium-quality bearing line is designed to provide extensive coverage for a wide range of industries including agriculture, medium-duty and automotive.

### BALL BEARINGS

- 52100 steel creates excellent hardness qualities for resistance against deformation and wear
- Wide range of shield, seal and size configurations for any application



Common Applications:  
Alternators, transmissions, engines, transfer cases

### TAPERED ROLLER BEARINGS

- Case-carburized rollers and raceways for 40% longer life compared to through-hardened products
- Specially designed for high axial, radial and combined load capacities



Common Applications:  
Transmissions, engines, differentials, wheel end, transfer cases

### CLUTCH PILOT BEARINGS

- High-quality construction ensures smooth and reliable shift quality, extending transmission and clutch life
- High-quality steel provides anti-friction alignment allowing for efficient power transfer and reduced shifting times in high-speed settings

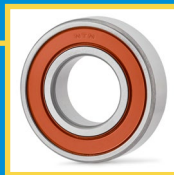

Common Applications:  
Transmissions

### CLUTCH RELEASE BEARINGS

- Decrease friction between the clutch release fork and the clutch pressure plate levers, allowing for smooth, noise-free disengagement of power from the engine to the transmission, extending service life
- High-strength steel construction and high-quality bearings allow for trouble-free operations under all loads



Common Applications:  
Transmissions

### CENTER SUPPORT BEARINGS

- Pre-lubricated and sealed bearing inserts prevent grease leakage while keeping moisture and contaminants out
- High-quality rubber cushions absorb and isolate vibrations helping to extend bearing life
- Cold-rolled steel construction increases strength and durability while a corrosion-resistant coating protects from environmental elements



Common Applications:  
Driveshafts

### WHAT IS CASE CARBURIZATION AND WHY IS IT CRITICAL?

The case carburization process creates bearings with a hard, wear-resistant outer shell and a tough, ductile core. The tough outer shell helps protect the rolling elements from debris, while the ductile core allows the bearing to both absorb increased shock loading and operate under misalignment without failing. These traits are critical in agriculture and heavy-duty applications, in which bearings are forced to operate in heavily contaminated environments.

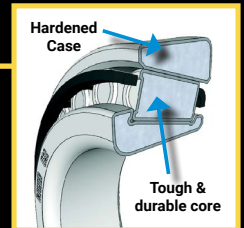

# Seals

## To ensure optimal leak and contaminant protection, you can depend on BCA Seals.

As the number one supplier of OE-quality hub assemblies, BCA understands the value of quality seals. BCA seals are designed and manufactured to meet OEM standards. Advanced polymer technologies utilizing materials like PTFE™ and Viton™, coupled with the most modern sealing design principles to ensure optimal leak and contaminant protection.



### Features & Benefits

- Multi-contact seal and grease lips keep lubricants in and contaminants out, providing continuous lubrication to reduce wear and aging
- Superior operation in wide range of temperatures provides optimal performance and long life
- Low seal swell reduces torque and improves vehicle gas mileage
- BCA engineers physically validate each SKU to ensure accuracy in form, fit & function

## Take a Bold Step. Cross the Line.

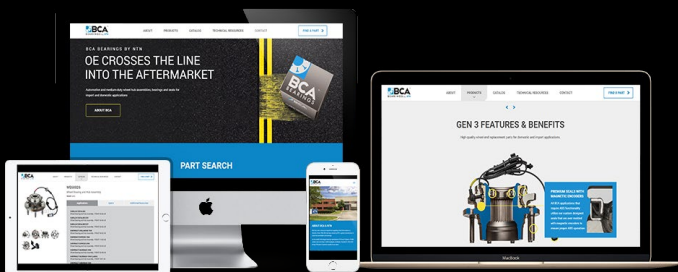

### We protect your investment by individually polybagging each seal to ensure:

- Rust inhibitor and pre-greased sealing lip do not dry out and cause the seal itself to rust or become dry.
- Seals are kept free from dirt and dust contaminants. A bearing with a dirty seal can cause premature seal failure.
- The polymer is protected from the likes of moisture and ozone which can shorten the shelf life of the seal dramatically

### Common Applications:

Wheel-end, transmission, differential, axle



## **OE Crosses The Line Into The Aftermarket**

### **Application-Specific Engineering Design**

- Delivers correct fit, function and maximum performance for each BCA product.

### **Components Made With Premium Quality Materials**

- Ensure customers receive a strong, durable product.

### **Over a Century of Continuous Improvement and Innovation**

- Give you the peace of mind you need.