

OWNERS MANUAL

...with installation instructions

Banks Monster® Exhaust System

**1998-2002 Dodge 5.9L Cummins
(24-valve) ISB Pickup Trucks**

THIS MANUAL IS FOR USE WITH

- MONSTER EXHAUST, SYSTEMS 48635/48636
- MONSTER EXHAUST W/ POWER ELBOW, SYSTEMS 48637/48638
- POWER ELBOW, ASSEMBLY 48639

BANKS

Also Available from Banks Power



Banks Monster-Ram 98-02 (P/N 42764)

- Increased flow from intercooler
- Raises boost without increasing backpressure at the turbine

Banks Exhaust Brake (P/N 55219, 55221)

- Increases the stopping power of your truck and extends the service life of your brakes

Banks SmartLock 98-02 (P/N 55262)

- Reduces wear on transmission
- Locks Torque Converter and raises trans-line pressure
- Works with Banks Exhaust Brake

Banks Diesel Tuner 98-02 Big Hoss (P/N 62781-62783)

- Adds power safely to your vehicle
- Engine and transmission safeguards
- Change power levels on-the-fly

Thermocouple

- Add a temperature limiting function to your Diesel Tuner .

Banks QuickTurbo 94-02 (P/N 24052, 24053)

- More boost through the powerband
- Does not over-boost
- Turbo-diesel efficiency

Banks BigHead® Actuator 98-02 (P/N 24329)

- Achieves a higher peak boost over stock and gives you precise boost control that gives you crisp acceleration and more mid-range pulling power.

Banks Billet Torque Converter 94-07 (P/N 72515)

- Higher torque capacity over stock
- Lockup clutch is slip-resistant so transmission fluids stay cooler and transmission life is prolonged.

Banks Git-Kit Systems 98-02 (P/N 49357-49362)

- Contains:**
- Monster Exhaust
 - OttoMind Tuner

Banks Stinger Systems 98-02 (P/N 49363-49374)

- Contains:**
- Ram-Air Filter
 - Monster Exhaust
 - OttoMind Tuner
 - Big Head Wastegate Actuator
 - Gauges

Banks Stinger-Plus Systems 98-02 (P/N 49320-49323, 49351, 49352)

- Contains:**
- Ram-Air Filter
 - Monster Exhaust
 - OttoMind Tuner
 - Big Head Wastegate Actuator
 - Gauges
 - Quick Turbo

Banks PowerPack Systems 98-02 (P/N 49330-49335, 49353-49356)

- Contains:**
- Ram-Air Filter
 - Monster-Ram
 - Monster Exhaust
 - OttoMind Tuner
 - Big Head Wastegate Actuator
 - Gauges
 - Quick Turbo

General Installation Practices

1. For ease of installation of your Banks Monster Exhaust System, please read this 8 page Owner's Manual before starting any work. Become thoroughly familiar with all components and phases of the installation before beginning any work. See **Figure 1** for a complete component listing.

2. Inspect all components supplied for any foreign material that may have entered during shipping and handling.

3. The installation should be performed at a time when the vehicle has been allowed to completely cool. This installation requires the installer to work near surfaces that may remain hot after the vehicle has been run. Failure to allow the vehicle to cool may result in personal injury.

4. Pay particular attention to the routing of wires. Keep them away from exhaust heat, moving parts and sharp edges that may cause damage. Route or tie away from critical areas as required. Keep all wires a minimum of 6" from hot exhaust parts, 8" or more is recommended whenever possible.

Warning! Never work under any vehicle supported only by a jack of any kind. DO NOT USE concrete blocks or other masonry items that may collapse under the vehicle weight.

Monster Exhaust System Installation

1. As a precaution, disconnect the ground of the battery (if there is more than one battery, disconnect both)

2. Raise the vehicle and support it with properly weight rated safety stands, ramps or a commercial hoist. Follow the manufacturer's safety precautions. Take care to balance the vehicle to prevent it from slipping or falling. When using ramps, be sure the front wheels are centered squarely on the topsides; place the transmission in park; set the parking brake and place blocks behind the rear wheels. **CAUTION: DO NOT WORK UNDER ANY VEHICLE SUPPORTED ONLY BY A JACK. SEVERE INJURY MAY RESULT.**

WARNING! The following step requires the use of a torch and/or saw. Proper safety equipment should be used. Failure to use proper safety equipment may result in severe injury.

3. Under the vehicle, remove the entire factory exhaust system. Starting at the rear of the vehicle, remove each component by either cutting through the pipe near the clamps or by removing the clamps and heating the joints to a red-orange color to allow

the crimped pipes to separate. Remove the pin-type hangers from the rubber frame mounts by prying with a pry-bar or by pressing the pin out of the rubber with large water pump pliers. A soapy water solution or a penetrating lubricant will ease the removal of pin-type hangers from the rubber frame mounts. Remove the two bolts that attach the turbine outlet pipe to the turbine outlet elbow and remove the turbine outlet pipe from the vehicle. Keep these bolts for later use. To remove the turbine outlet pipe, it may be necessary to cut the pipe just to the rear of the pin hanger that slides into the hanger bracket on the transmission mount.

NOTE: If a Banks Power Elbow is being installed along with the Monster Exhaust, continue with step 4 otherwise skip to step 8.

4. Remove the air cleaner box assembly (including the black flex hose) from the passenger side of the vehicle.

5. Remove the five (5) 8-mm bolts that attach the factory turbine outlet casting to the turbine housing. Remove the turbine outlet casting and gasket.

6. Install the Banks Power Elbow casting on the outlet of the turbine housing using the five (5) 8-mm bolts and flat washers provided. See

Figure 2.

NOTE: Do Not re-use the stock turbine outlet gasket. The fully-machined mating surface on the Banks Power Elbow does not require a gasket for adequate sealing. Use the supplied anti-seize compound on the bolts and tighten them evenly. Torque each bolt to 160 in-lbs.

7. Position the supplied Banks Monster T.O.P. turbine outlet pipe onto the turbine outlet elbow ball flange. See **Figure 1.**

A. If the Banks Power Elbow is being installed, attach the Banks Monster T.O.P. turbine outlet pipe to the Power Elbow using the supplied $\frac{7}{16}$ bolts and washers. Apply supplied Anti-seize to threads. Do not completely tighten the bolts at this point in the installation.

B. If the factory outlet elbow is being re-used, install the previously removed attaching bolts to hold it in place, but do not tighten them at this point in the installation.

CAUTION: The following step involves cutting a stainless steel tube. Safety glasses should be worn during any cutting operation and care should be taken to avoid injury due to sharp edges and burrs.

NOTE: Once a pipe has been completely engaged in a slip joint, it should be marked with a marker, scribe or tape for reference when tightening clamps later in the installation. Each slip joint in the system should be marked in this fashion. When the exhaust system is being adjusted to align the hangers, the slip joints can be adjusted so that the reference mark is no more than 1/4" away from its original position.

8. Place a 4" muffler clamp onto the outlet of the turbine outlet pipe, and then slide the intermediate pipe into the hanger at the transmission mount, and onto the turbine outlet pipe. *Note: on extended cab short bed models, it maybe necessary to shorten the intermediate pipe. Install the muffler and tailpipe without clamps and determine how much to trim based on the hanger position. The remaining length of extension pipe should be approximately 10" long.*

9. On extended cab/quad-cab long bed models only, position another 4" clamp onto the outlet end of the intermediate pipe, and install the extension pipe onto the intermediate pipe.

10. Install the muffler assembly onto the end of the extension or intermediate pipe. Temporarily support the muffler and install the hanger clamp at the front of the muffler. Snug the nuts, but do not fully tighten them.

11. At the rear of the muffler, slip a 4" clamp over the outlet of the muffler. Install the tailpipe up over the axle, and into the muffler outlet. Place the hanger pins into the rubber frame mounts behind the axle. Slip the 5" Monster tailpipe tip on. Keep the wrapping on until installation is complete. The tip should be rotated so the clamp nut is pointing down. Install the 5" tip so that it hangs past the end of the tailpipe by 1" for fleet-side trucks and 2 1/2" for duallies or where aesthetically pleasing.

Figure 2

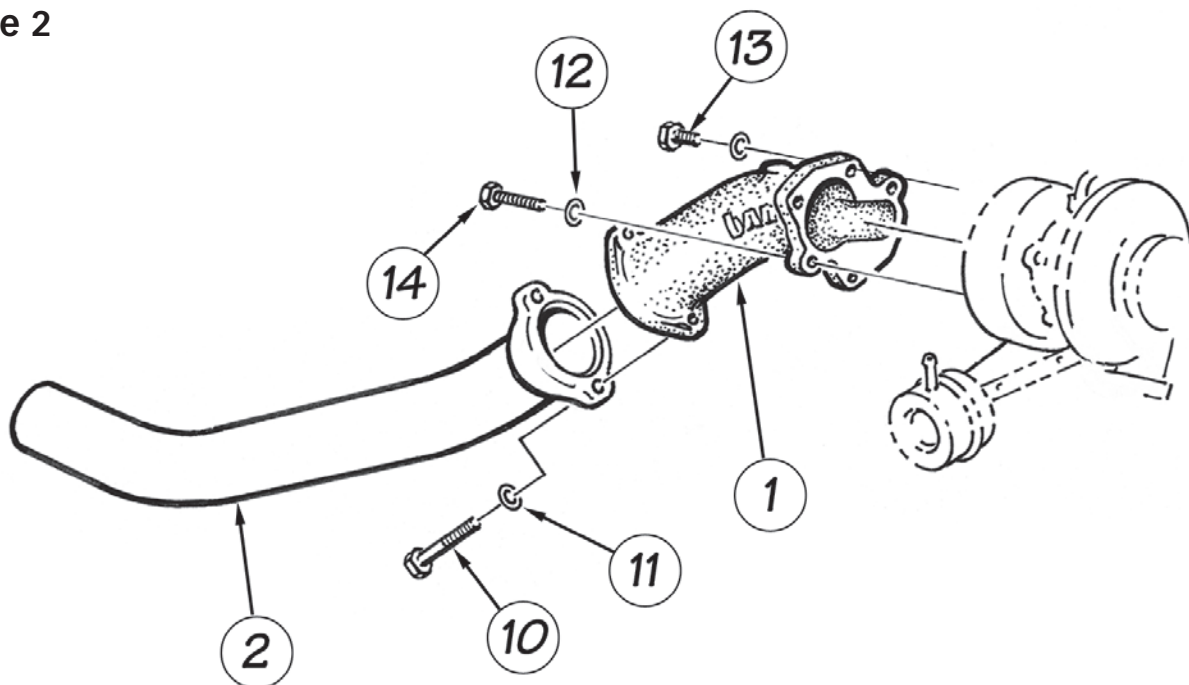

12. A. If the Banks Power Elbow was installed, Torque the two (2) $\frac{7}{16}$ " turbine outlet pipe attach bolts to 15 ft-lbs. *NOTE: Do not use an impact wrench on these fasteners. The wide span of the two-bolt spherical flange creates sufficient clamping force when 15 ft-lbs is used. Exceeding this torque specification will not increase the sealing performance.*

B. If the factory turbine outlet elbow was utilized, torque the turbine outlet pipe attach bolts to **23** ft-lbs.

13. Starting from the front of the exhaust system and working back, evenly torque each of the nuts on the exhaust clamps to 35 ft-lbs. Make sure that each slip joint is fully inserted ($\pm\frac{1}{4}$ inch), and that all frame mount hangers are hanging in the forward position. See **Figures 3** and **4**.

14. Lower the vehicle.

15. Remove protective covering from tailpipe tip.

CAUTION: Failure to remove protective covering from tailpipe tip may lead to severe personal injury or damage to the vehicle. The protective covering may ignite and burn if not removed prior to running the engine.

16. Re-connect battery terminals if previously removed.

17. Monster exhaust system installation is now complete.

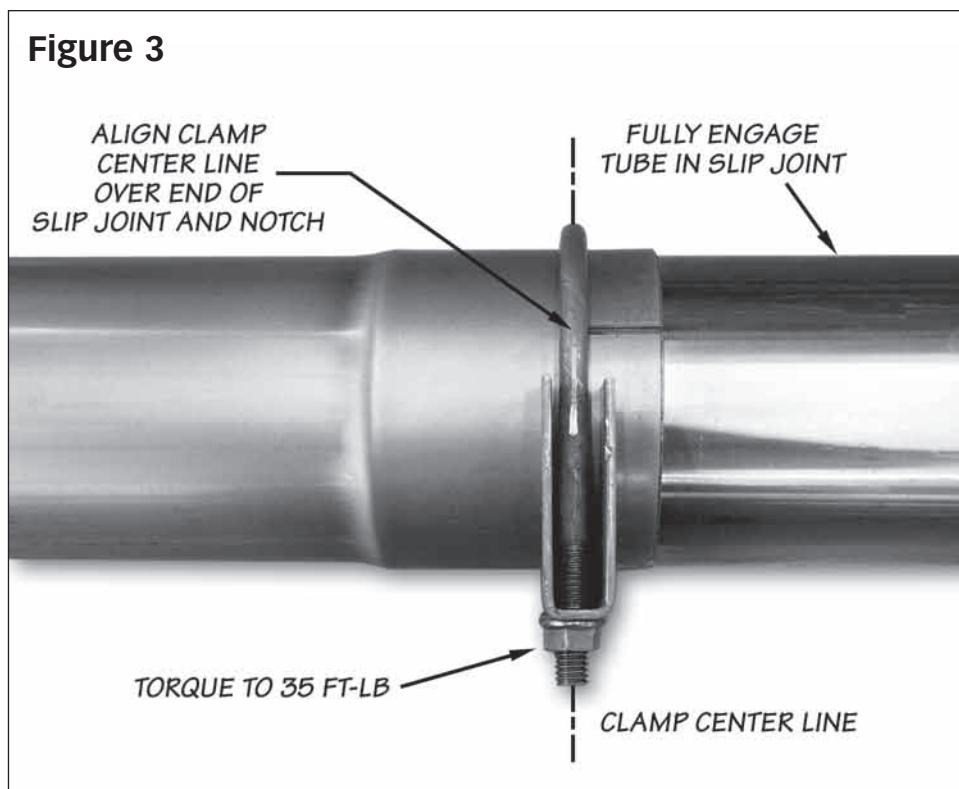
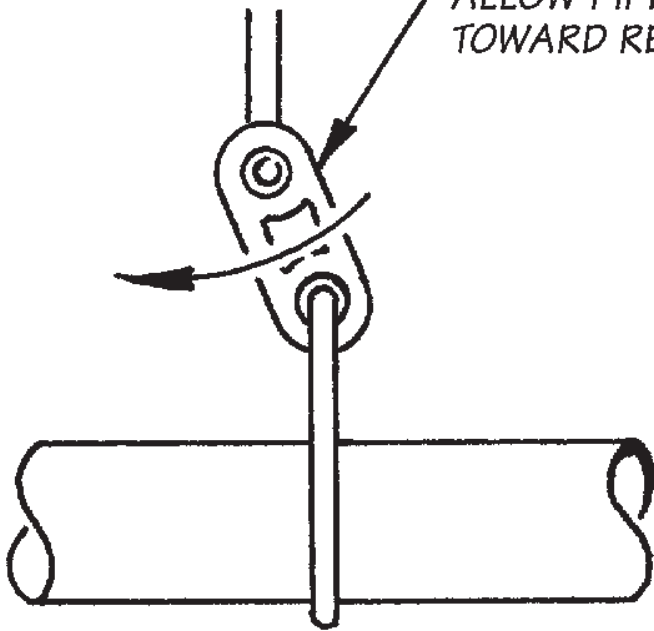

Figure 4

HANGER ANGLE SHOULD
ALLOW PIPE TO EXPAND
TOWARD REAR OF VEHICLE



← DIRECTION OF PIPE EXPANSION

← REAR OF VEHICLE