

**banks**

with Installation Instructions

# Owner's Manual

## **Banks Monster<sup>®</sup> Exhaust**

**1987-2001 Cherokee (XJ)**

THIS MANUAL IS FOR USE WITH SYSTEMS 51360

**BANKS**

# General Installation Practices

**1.** For ease of installation of your Banks system, familiarize yourself with the procedure by reading the entire manual before starting work.

**2.** The exploded view (Figure 1) provides only general guidance. Refer to each step and section diagram in this manual for proper instruction.

**3.** Throughout this manual, the left side of the vehicle refers to the driver's side, and the right side to the passenger's side.

**4.** Disconnect the ground cable from the battery (or batteries, if there are two) before beginning work.

**5.** Route and tie wires and hoses a minimum of 6" away from exhaust heat, moving parts and sharp edges. Clearance of 8" or more is recommended where possible.

**6.** When raising the vehicle, support it on properly weight-rated safety stands, ramps or a commercial hoist. Follow the manufacturer's safety precautions. Take care to balance the vehicle to prevent it from slipping or falling. When using ramps, be sure the front wheels

are centered squarely on the topsides; put the transmission in park; set the hand brake; and place blocks behind the rear wheels.

**CAUTION! Do not use floor jacks to support the vehicle while working under it. Do not raise the vehicle onto concrete blocks, masonry or any other item not intended specifically for this use.**

**7.** During installation, keep the work area clean. Do not allow anything to be dropped into intake, exhaust, or lubrication system components while performing the installation, as foreign objects will cause immediate engine damage upon start-up.

## Tools Required:

- 1/4" and 3/8" drive ratchets with inch and metric sockets and 1/4" and 3/8" drive extension
- Inch and metric combination or open-end wrenches
- Standard screwdriver
- Standard and needle-nose pliers
- Reciprocating saw
- Clean shop towels or rags

## Highly recommended tools and supplies:

- Inch-pound and foot-pound torque wrenches
- Compressed air source and hose
- Air pressure regulator
- Penetrating oil or light lubricant spray

# Products available from Banks Power for the Jeep 4.0L



**Torque Tubes®**  
2000-2006 4.0L (P/N 51306)

**Revolver® Exhaust Manifold**  
1991-1999 (P/N 51327)

- Virtually indestructible
- Each Torque Tube and Revolver has a seamless high-velocity collector.
- Literally “pulls” out the exhaust, unleashing greater torque and helping the intake stroke to draw in more air.

**Figure 1 (General Assembly)**

| ITEM # | PART # | DESCRIPTION                        | QTY. |
|--------|--------|------------------------------------|------|
| 1      | 52640  | MUFFLER, S/S - 1987-01 JEEP 4.0L   | 1    |
| 2      | 52624  | TAILPIPE, FRONT                    | 1    |
| 3      | 52625  | TAILPIPE, REAR                     | 1    |
| 4      | 52459  | EXHAUST CLAMP, 2 1/4" SADDLE STYLE | 1    |
| 5      | 52461  | EXHAUST CLAMP, 2 1/2" HD           | 2    |
| 6      | 52462  | EXHAUST CLAMP, BAND STYLE - 2 1/2" | 1    |

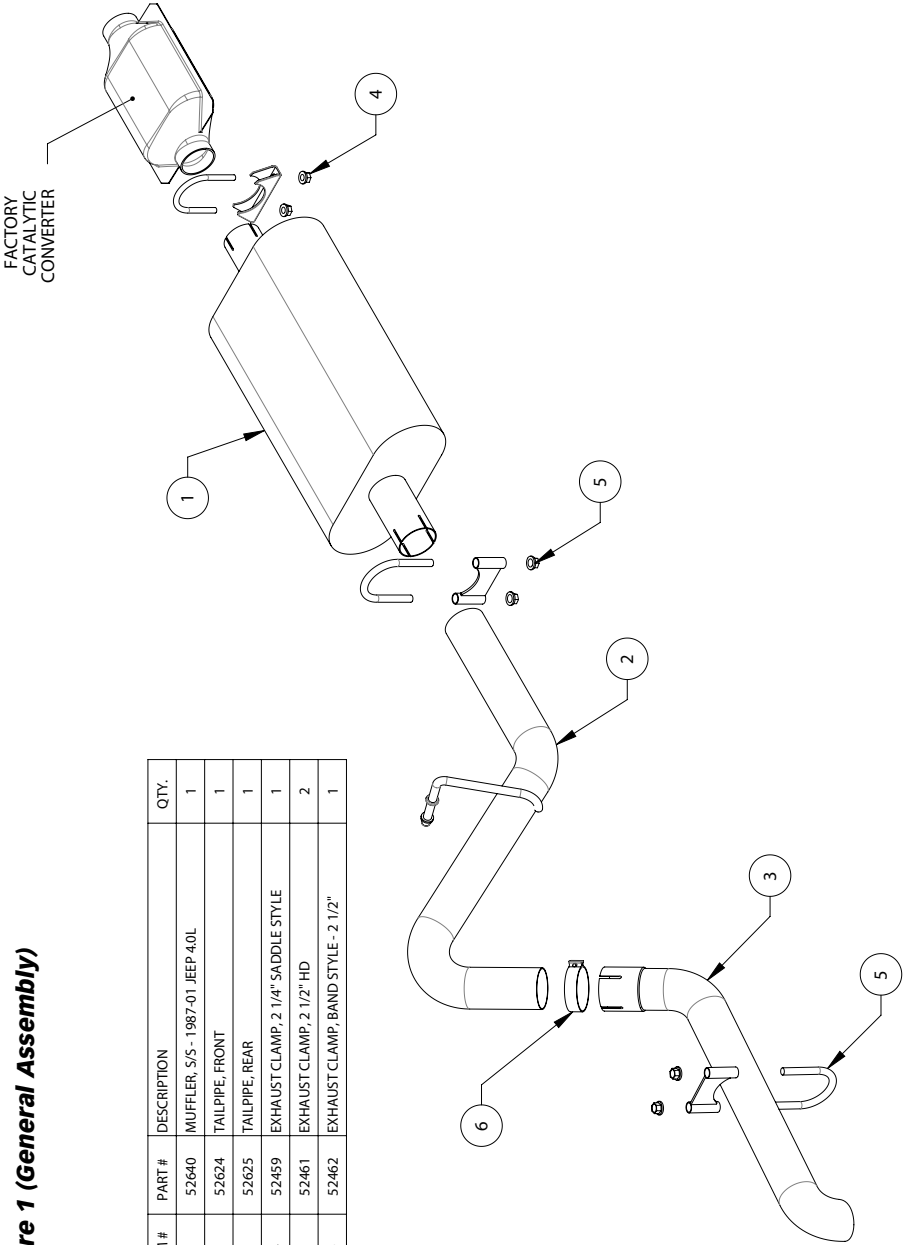

# Installation Instructions

**1.** Disconnect the negative (ground) cable from the battery (if there is more than one battery, disconnect both negative cables). Secure the cable so it cannot accidentally come in contact with the post.

**⚠WARNING:** *Do not use floor jacks to support the vehicle while working under it. Do not raise the vehicle onto concrete blocks, masonry or any other item not intended specifically for this use.*

**⚠WARNING:** *The following steps may require the use of a torch and/or saw. Proper safety equipment should be used. Failure to use proper safety equipment may result in severe injury.*

**2.** Raise the vehicle on a hoist or safety stands to provide access to the exhaust system. Support it securely

with properly weight-rated safety stands, ramps, or a commercial hoist. Take care to balance the vehicle to prevent it from slipping or falling. When using ramps, be sure the wheels are centered squarely on the topsides. Place the transmission in park (automatic), set the parking brake and securely block the wheels that are on the ground.

**3.** From under the vehicle, remove the factory exhaust system from the catalytic converter back (if applicable, be sure to remove the Oxygen Sensor before operating the saw or torch). Cut the tailpipe at the junction of the muffler and the converter leaving about 2 1/2" minimum on the converter (**see Figure 2**).

**⚠NOTICE:** *Do not puncture or damage the catalytic converter during the removal process.*

**Figure 2**

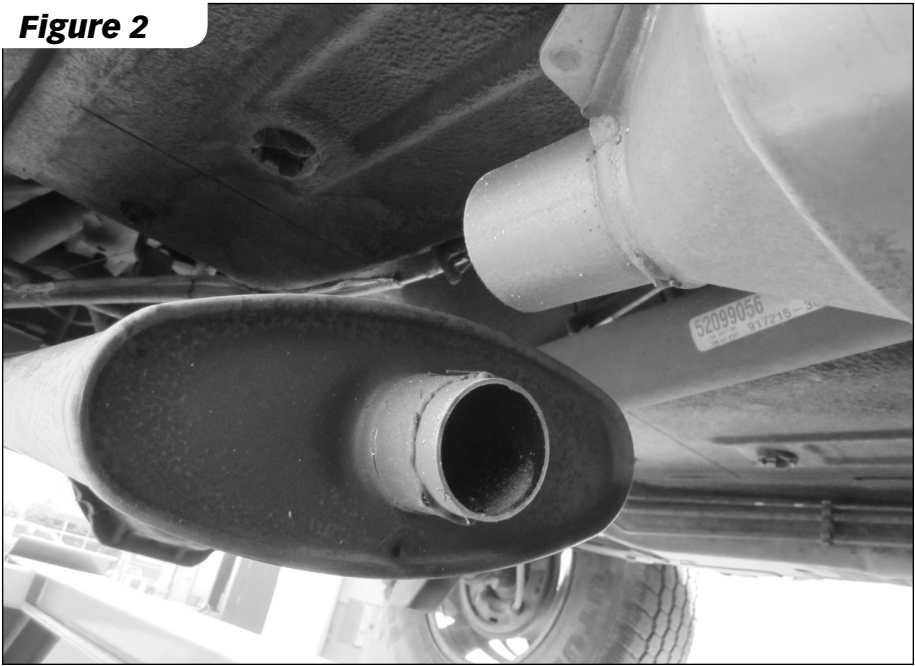

**Figure 3**



**4.** Starting at the rear of the vehicle, remove the exhaust clamp from the tailpipe hanger and the hanger pin from the rubber hanger. O.E. rear tailpipe hanger and rubber hanger will be re-used. (Spray lubricant will ease hanger pin removal.) Remove the muffler and tailpipe from vehicle.

**5.** Install the Banks Monster Muffler onto the catalytic converter. Be sure the muffler inlet is facing towards the catalytic converter. Position the muffler so that it is straight and level with the vehicle with the Banks logo facing downward. Loosely install the supplied 2 ¼" clamp onto the muffler and catalytic converter connection (see **Figure 3**).

**6.** Remove plug from the pre-installed bung fitting, and reinstall Oxygen Sensor as shown (see **Figure 4**).

**For models with Oxygen Sensor on the Catalytic Converter. All others proceed to step 10.**

**7.** Locate the supplied Banks tailpipe. You will need to cut-off the end that fits to the muffler outlet side.

**8.** Measure 2 ½" on the side that connects to muffler outlet and mark the location (see **Figure 5**).

**9.** Take time when measuring and cutting the tailpipe to ensure proper location and a straight cut. Improper

**Figure 4**

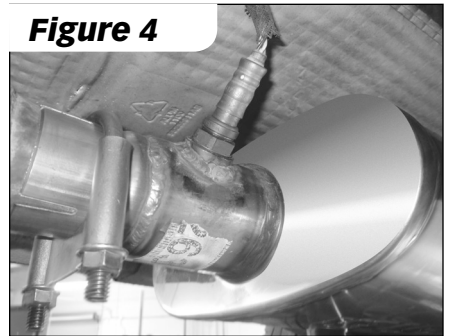

cut will result in poor fitment of the Banks Monster Exhaust system. Using a reciprocating saw, cut the tailpipe.

**10.** Install one of the supplied 2 ½" clamps onto the muffler outlet. Install the front tailpipe inlet into the muffler outlet and loosely tighten the clamp. Connect the tailpipe hanger pin to the factory rubber hanger. Slip the rear tailpipe onto the front tailpipe and install the other supplied 2 ½" band clamp over the tailpipe hanger. Do not tighten any of the clamps or fittings at this point.

**11.** Install the supplied 2 ½" exhaust clamp onto the rear tailpipe hanger. Position exhaust clamp as shown (see **Figure 6**).

**12.** Position all the exhaust components such that all the hanger pins are parallel with the frame pins

**Figure 5**

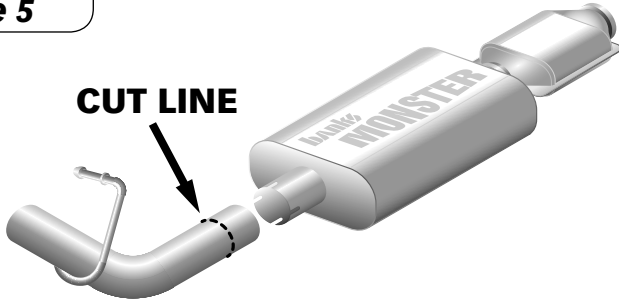

**Figure 6**

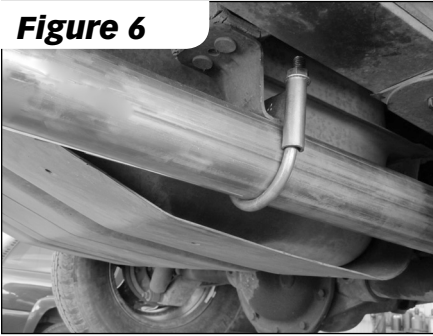

and all exhaust tubing is located properly. Lightly tighten clamps to maintain position. All hangers should be hanging slightly forward to allow for heat expansion of the exhaust tubing (see Figure 7).

**13.** With everything positioned properly, torque the clamps to 25-30 ft-lbs.

**14.** Reconnect the battery. Start the vehicle and listen for exhaust leaks. Tighten the clamps as necessary. Whenever possible, tack-welding slip connections to prevent disengagement is highly recommended.

***NOTICE***: The vehicle exhaust may smoke upon initial start-up. This is normal, as grease used in

**Figure 7**

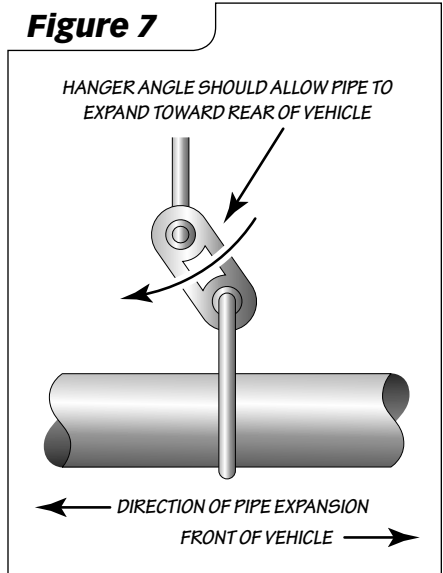

**the tube bending process burns off the pipes.**

**15.** The Banks Monster Exhaust system contains two (2) Banks Power decals. For a clean factory look, it is recommended that the decals are placed above the "Cherokee" emblem on the passenger and driver side front fenders.

**16.** Your Banks Monster Exhaust system installation is now complete.