

banks

with Installation Instructions
Owner's Manual

Banks Monster[®]
Exhaust System

**2008-2010 Ford Power Stroke 6.4L
Turbo-Diesel F250/F350 Trucks**

THIS MANUAL IS FOR USE WITH SYSTEMS 49780 & 49781

BANKS

Products available from Banks Power for the '08-10 Ford 6.4L



Banks iQ System (P/N 61155)

- 5" touchscreen interface that can control the Banks Diesel Tuner and/or SpeedBrake on the fly.
- Interchangeable gauge display, read and clear codes, monitor engine diagnostics, log data, time your vehicles runs and much more.

Banks Ram-Air Intake System (P/N 42185)

- Increases your airflow over stock.
- Adds power, improves fuel economy, lowers EGTs and reduces smoke.

Banks Techni-Cooler® System (P/N 25984)

- Provides increased air flow to the engine by increasing air density for more increased power, lower EGTs and improved fuel economy.

Banks Exhaust Brake (P/N 55469)

- Increases the stopping power of your truck and extends the service life of your brakes

Banks SpeedBrake (P/N 55464)

- Allows for controlled hill decent at a user defined vehicle speed.

Banks Diesel Tuner Six-Gun (P/N 63907)

- Adds power safely to your vehicle
- Engine and transmission safeguards
- Change power levels on-the-fly

**OttoMind Programmer
(P/N 66063)**

- Contains Banks tunes that boost your vehicles HP, Torque and MPG.
- Displays a host of critical engine functions
- Provides "service technician" diagnostic capabilities
- Has upgradeable functionality, so it will never be out of date

**Six-Gun Bundle
(P/N 46652-46655)**

Contains:

- Monster Exhaust (single and dual)
- Ram-Air Intake
- Six-Gun Tuner w/ Banks iQ

**Big Boss Bundle
(P/N 46656-46659)**

Contains:

- Monster Exhaust (single and dual)
- Ram-Air Intake
- Six-Gun Tuner w/ Banks iQ
- Techni-Cooler

General Installation Practices

1. Before starting work, familiarize yourself with the installation procedure by reading all of the instructions.
2. The exploded view (**Figure 1**, pages 4-5) provides only general guidance. Refer to each step and section diagram in this manual for proper instruction.
3. Throughout this manual, the left side of the vehicle refers to the driver's side, and the right side to the passenger's side.
4. Disconnect the negative (ground) cable from the battery (or batteries, if there are two) before beginning work.

5. Route and tie wires and hoses a minimum of 6" away from exhaust heat, moving parts, and sharp edges. Clearance of 8" or more is recommended where possible.

6. When raising the vehicle, support it on properly weight-rated safety stands, ramps or a commercial hoist. Follow the manufacturer's safety precautions. Take care to balance the vehicle to prevent it from slipping or falling. When using ramps, be sure the front wheels are centered squarely on the topsides. When raising the front of the vehicle, put the transmission in park (automatic) or reverse (manual), set the parking brake, and block the rear wheels. When raising the back of the vehicle, be sure the vehicle is on level ground and the front wheels are blocked securely.

CAUTION! Do not use floor jacks to support the vehicle while working under it. Do not raise the vehicle onto concrete blocks, masonry or any other item not intended specifically for this use.

7. During installation, keep the work area clean. Do not allow anything to be dropped into intake, exhaust, or lubrication system components while performing the installation, as foreign objects will cause immediate engine damage upon start-up.

Tools Required:

- 1/2" and 3/8" drive ratchets with inch and metric sockets and 1/2" and 3/8" drive extension
- Inch and metric combination or open-end wrenches
- Standard screwdriver
- Clean shop towels or rags
- Pry-bar
- Reciprocating saw

Highly recommended tools and supplies:

- Foot-pound torque wrenches
- Penetrating oil or light lubricant spray
- Oxy-acetylene torch

Figure 1

General Assembly Diagram

Item	Description	P/N	Qty.
1	Intermediate Pipe	53980	1
2*	Intermediate Pipe Extension	53987	1
3	Front Tailpipe	53988	1
4	Rear Tailpipe	53982	1
5	Tip, Tailpipe	52726	1
6	Exhaust Clamp, 3 1/2"	52468	1
7*	Hanger Clamp, 4"	53986	1
8	Rear Hanger Clamp, 4"	53981	1
9**	Exhaust Clamp, 4"	52470	1
10	Exhaust Band Clamp, 4"	52471	1
11	Urocal, Bank Power	96009	2

* For Crew Cab Long Bed only.

** Crew Cab Long Bed contains two (2) 4" Exhaust Clamp.

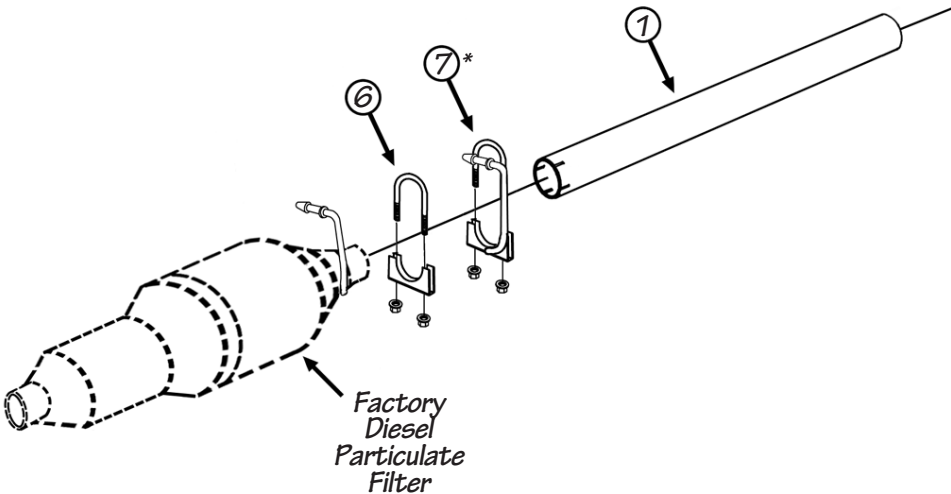

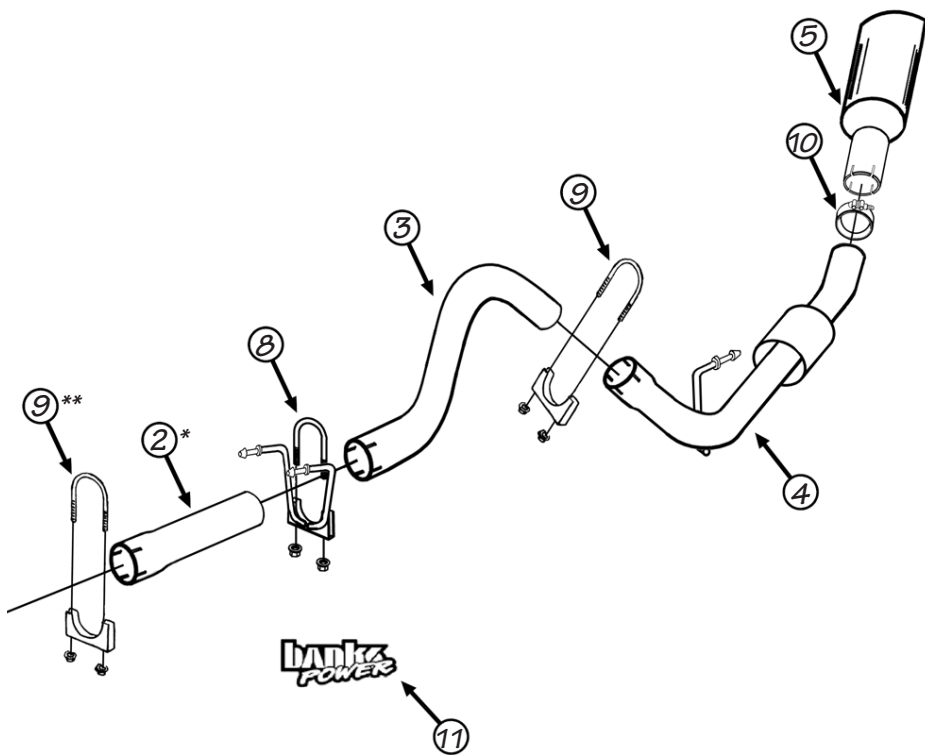

Monster Exhaust System Installation

1. As a precaution, disconnect the ground of the battery (if there is more than one battery, disconnect both).
2. Raise the vehicle and support it with properly weight rated safety stands, ramps or a commercial hoist. Follow the manufacturer's safety precautions. Take care to balance the vehicle to prevent it from slipping or falling. When using ramps, be sure the front wheels are centered squarely on the topsides; place the transmission in park; set the parking brake and place blocks behind the rear wheels.

CAUTION: DO NOT WORK UNDER ANY VEHICLE SUPPORTED ONLY BY A JACK. SEVERE INJURY MAY RESULT.

WARNING! The following step may require the use of a torch and/or saw. Proper safety equipment should be used. Failure to use proper safety equipment may result in severe injury.

3. Starting at the rear of the vehicle, remove the tailpipe near the intermediate pipe clamps by cutting through the connection or by removing the clamps and heating the joints with an oxy-acetylene torch to allow crimped pipes to separate. Remove the tailpipe from the vehicle.
4. Remove the clamps on the Diesel Particulate Filter to intermediate pipe. **TAKE CAUTION TO NOT CUT OR DAMAGE DIESEL PARTICULATE FILTER TUBING DURING THE REMOVAL PROCESS.** Separate the intermediate pipe to Diesel Particulate Filter connection.

NOTE: the use of an oxy-acetylene torch may be necessary. Remove the intermediate pipe hanger pins from the rubber hangers with a pry bar (Spray lubricant will ease hanger removal) and remove the intermediate pipe assembly from the vehicle.

5. Locate the supplied intermediate pipe and cut the intermediate pipe based on the following configurations. See **Table 1**. Cut the NON-swaged end of the intermediate pipe. See **Figure 2**.
6. Install a 3 $\frac{1}{2}$ " exhaust clamp onto the front of the Banks intermediate pipe. Install the intermediate pipe onto the Diesel Particulate Filter outlet. Loosely snug the 3 $\frac{1}{2}$ " clamp.
7. **For Crew Cab Long Bed Models Only, all other models skip to step 9.**
Slide the supplied hanger clamp onto the intermediate pipe. Insert the hanger pin into the factory rubber hanger.
8. Locate the supplied intermediate pipe extension for the Crew Cab Long Bed model. Install supplied 4" exhaust clamp onto the inlet of the pipe extension. Install extension pipe onto the intermediate pipe and loosely snug the exhaust clamp.
9. Install the rear hanger clamp onto the intermediate pipe outlet with the hanger pins facing the front of the vehicle. Insert the two (2) hanger pins into the rear rubber hangers and adjust the hanger clamp to a position that best supports the intermediate pipe. See **Figure 3**.

Figure 2

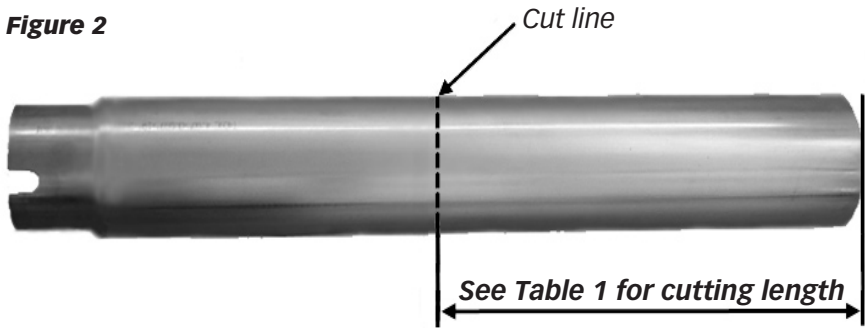

Table 1

2008-2010 Ford Power Stroke 6.4L		
	Wheel Base	Cut this length from the Intermediate Pipe. See Figure 2 .
Super Cab/ Short Bed	141.8"	20"
Crew Cab/ Short Bed	156.2"	No Cut
Crew Cab/ Long Bed	172.4"	No Cut

Figure 3

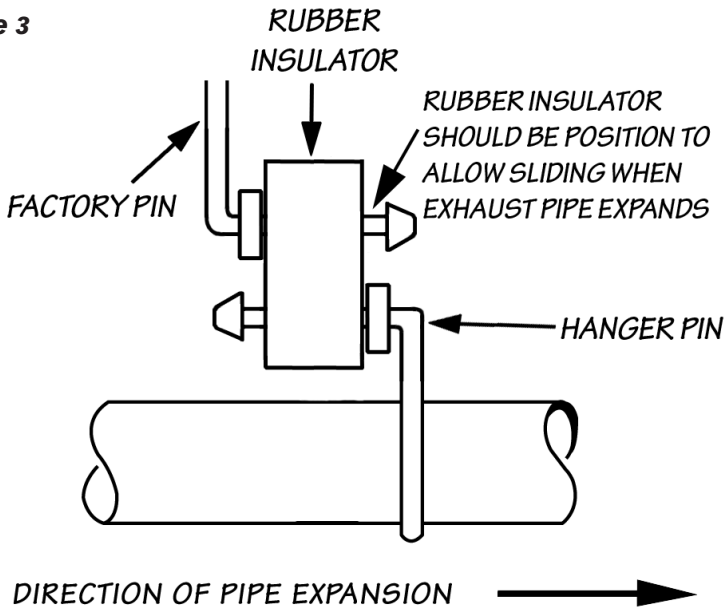

Figure 4 Placement of template on Passenger side rear undercarriage lining.



10. Route the Front Tailpipe over the rear axle housing and install the Front Tailpipe onto the Banks Intermediate pipe outlet. Loosely snug the rear hanger clamp.

11. Install the 4" exhaust clamp onto the inlet of the Rear Tailpipe. Start the Rear tailpipe hanger pin into the corresponding vehicle rubber hanger. Position the rubber hanger as shown in **Figure 3**. Install the Rear Tailpipe over the outlet of the Front Tailpipe. Slide the 4" clamp into position that best supports the tailpipe assembly. Loosely snug the hanger clamp on the intermediate pipe outlet.

NOTE: Maintain an adequate air gap clearance of one (1) inch between the exhaust and the shock absorber and between the exhaust and the spare tire.

12. Install Banks Monster tailpipe tip with exhaust band clamp on the exhaust. Keep the wrapping on until installation is complete. Adjust the tip past the edge of the body or where aesthetically pleasing. Loosely snug the 4" clamp.

NOTE: Minimum distance between exhaust tip and body is one (1) inch.

CAUTION: IF THE TAILPIPE IS IN CONTACT WITH THE REAR UNDERCARRIAGE FENDER LINING, USE TEMPLATE 1 TO TRIM THE LINING AS SHOWN IN FIGURE 4.

13. With everything positioned properly, begin to tighten the clamps starting with the ones closest to the turbo and working your way back. Evenly torque the exhaust clamps to 35 ft-lbs. Make sure that each slip is fully inserted (+/- 1/4 inch).

Figure 5

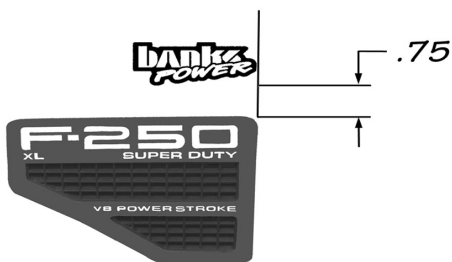

TYPICAL LEFT FENDER

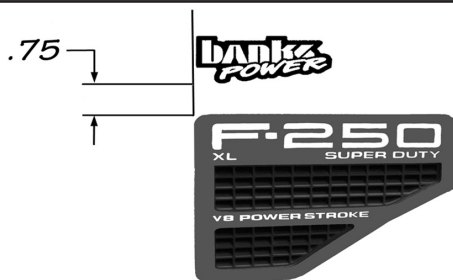

TYPICAL RIGHT FENDER

14. Remove the protective covering from the tailpipe tip.

CAUTION: THE PROTECTIVE COVERING MAY IGNITE AND BURN IF NOT REMOVED PRIOR TO RUNNING THE ENGINE.

15. Your system includes two "Banks Power" logos designed to complement the Ford badging on your truck. Use the provided measurements (see **Figure 5**) to position the logos for a clean factory look.

16. Re-connect battery terminals if previously removed. Banks Monster Exhaust installation is now complete.

2008-2010 Ford 6.4L Power Stroke F-250/F-350 Banks Monster Exhaust System

