

banks[®]

with Installation Instructions
Owner's Manual

Banks Monster[®]
Exhaust System

**2004-08 Ford/Lincoln
F-150/Mark-LT (4.2L, 4.6L & 5.4L)
New Body Style (Non-Heritage models)**

THIS MANUAL IS FOR USE WITH SYSTEMS 48739-48743

banks

General Installation Practices

1. Before starting work, familiarize yourself with the installation procedure by reading all of the instructions.
2. The exploded view (**Figure 1**) provides only general guidance. Refer to each step and section diagram in this manual for proper instruction.
3. Throughout this manual, the left side of the vehicle refers to the driver's side, and the right side to the passenger's side.
4. Disconnect the negative (ground) cable from the battery (or batteries, if there are two) before beginning work.
5. Route and tie wires and hoses a minimum of 6" away from exhaust heat, moving parts and sharp edges. Clearance of 8" or more is recommended where possible.
6. When raising the vehicle, support it on properly weight-rated safety stands, ramps or a commercial hoist. Follow the manufacturer's safety precautions. Take care to balance the vehicle to prevent it from slipping or falling. When using ramps, be sure the front wheels are centered squarely on the topsides. When raising the front

of the vehicle, put the transmission in park, set the parking brake, and block the rear wheels. When raising the back of the vehicle, be sure the vehicle is on level ground and the front wheels are blocked securely.

CAUTION! Do not use floor jacks to support the vehicle while working under it. Do not raise the vehicle onto concrete blocks, masonry or any other item not intended specifically for this use.

7. During installation, keep the work area clean. Do not allow anything to be dropped into intake, exhaust, or lubrication system components while performing the installation, as foreign objects will cause immediate engine damage upon start-up.

Tools Required:

- 1/2" and 3/8" drive ratchets with standard and metric sockets and 1/2" and 3/8" drive extension
- Standard and metric combination or open-end wrenches
- Standard screwdriver
- Clean shop towels or rags
- Pry-bar

Highly recommended tools and supplies:

- Foot-pound torque wrench
- Penetrating oil or light lubricant spray

Products available from Banks Power for the 04-08 Ford F-150 (4.2, 4.6, 5.4L)



Banks Ram-Air Intake System (P/N 41806)

- Increases your airflow over stock.
- Adds power, improves fuel economy, lowers EGTs and reduces smoke.

Torque Tubes (P/N 48715)

- Virtually indestructible
- Each Torque Tube has a seamless high-velocity collector.
- Literally "pulls" out the exhaust, unleashing greater torque and helping the intake stroke to draw in more air.

AutoMind Programmer (P/N 66100)

- Contains Banks tunes that boost your vehicles HP, Torque and MPG.
- Displays a host of critical engine functions
- Provides "service technician" diagnostic capabilities
- Has upgradeable functionality, so it will never be out of date

General Assembly

Figure 1

Item#	Description	Part #	Qty
1a	Intermediate pipe (SCMB, CCSB, CCMB, ECMB, ECLB)	53361	1
1b	Intermediate pipe (ECSB)	53362	1
2	Rear intermediate pipe (CCSB, CCMB, ECMB, ECLB)	53391	1
3	Extension Intermediate Pipe (ECLB)	53392	1
4	Hanger Clamp 3" (CCSB, CCMB, ECMB, ECLB)	53393	1*
5	Banks Monster Muffler	53962	1
6	Tailpipe, Front	53383	1
7	Tailpipe, Rear	53384	1
8	Band Clamp, 3.5"	52467	1
9	Monster Tip	52718	1
10	Exhaust Clamp, 2.5"	52461	1
11	Exhaust Clamp, 3"	52465	2**
12	Exhaust Clamp, 3.5"	52468	1
13	Banks Urocals	96009	2

* SCMB & ECSB Do Not Require/Include hanger clamp

** ECMB, CCSB & CCMB contain three (3) clamps

** ECLB contains four (4) clamps

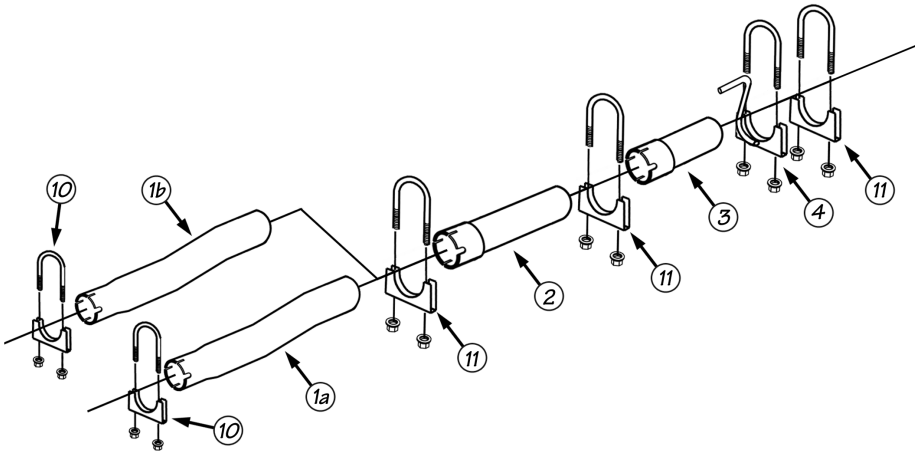

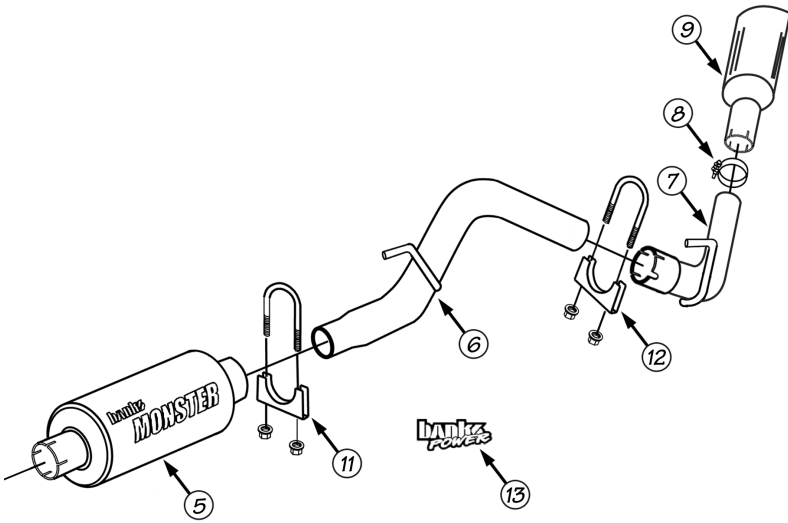

Legend Key

Abbreviation	Description
SC	Standard Cab
EC	Extended Cab
CC	Crew Cab
SB	Short Bed (5 1/2')
MB	Medium Bed (6 1/2')
LB	Long Bed (8')

Monster Exhaust Installation

1. Disconnect the negative (ground) cable from the battery (if there is more than one battery, disconnect both negative cables). Secure the cable so it cannot accidentally come in contact with the post.

2. Raise the vehicle and support it securely with properly weight-rated safety stands, ramps or a commercial hoist. Take care to balance the vehicle to prevent it from slipping or falling. When using ramps, be sure the wheels are centered squarely on the topsides. Place the transmission in park (automatic), set the parking brake and securely block the wheels that are on the ground.

CAUTION: DO NOT WORK UNDER ANY VEHICLE SUPPORTED ONLY BY A JACK. SEVERE INJURY MAY RESULT.

3. From under the vehicle remove the factory exhaust starting at the rear of the muffler. Remove the tailpipe by removing and retaining the two (2) M8x1.25 bolts supporting the rear tailpipe hanger. Remove and retain the rear rubber hanger from the tailpipe. See **Figure 2**.

4. Loosen the factory band clamp at the front of the muffler. Using spray lubricant, lube the front and rear muffler hanger pins. Remove the muffler and tailpipe assembly from the vehicle. See **Figure 3**.

NOTE: Removing the rubber hangers from the vehicle may assist in exhaust removal.

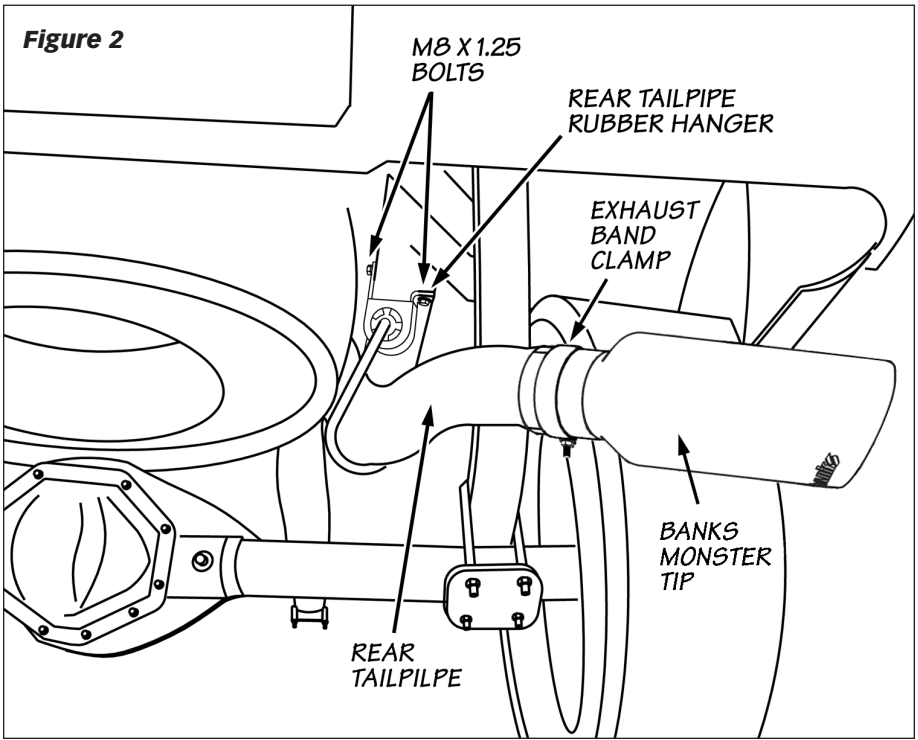
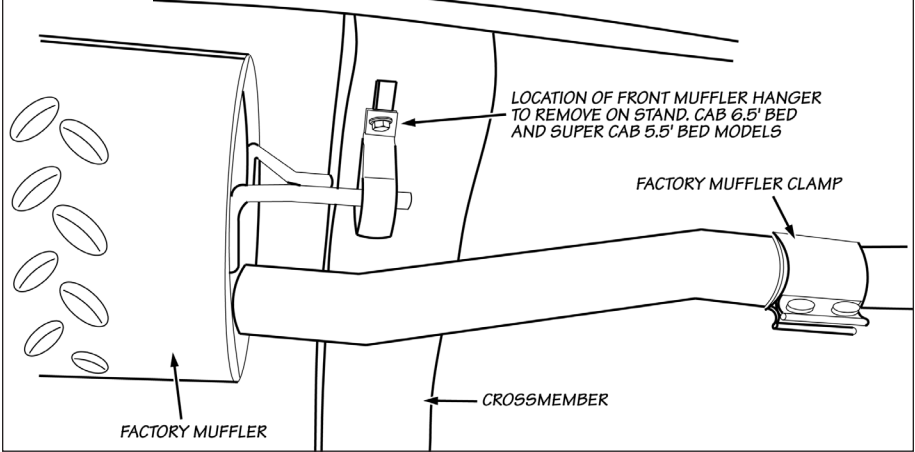

Figure 3



5. If applicable, loosen the factory band clamp on the intermediate pipe. Using spray lubricant, lube the intermediate pipe hanger pins and remove the intermediate pipe from the vehicle.

6. FOR SCMB AND ECSB MODELS ONLY. Due to the enormous weight reduction of the Banks Exhaust system, the factory muffler front rubber hanger will be removed for Std. Cab Medium (6.5') Bed and Ext. Cab Short (5.5') Bed models. Remove the factory M8x1.25 bolt on the rubber muffler hanger, and remove the rubber hanger from the vehicle. See **Figure 3**.

7. Install a 2½" clamp onto the inlet of the Banks intermediate pipe. Install the Banks intermediate pipe to the factory Y-pipe outlet. Orient the pipe onto the locating pin and lightly tighten the 2½" clamp to secure the intermediate pipe (see **Figure 4**).

FOR ECMB & CCSB CONTINUE TO STEP 8.

FOR ECLB & CCMB SKIP TO STEP 9.

FOR ECSB & SCMB SKIP TO STEP 13.

8. FOR ECMB & CCSB ONLY. For the ECMB cut off 6.75" from the non swaged side of the Rear Intermediate pipe. For the CCSB cut off 12.75" from the non swaged end of the Rear Intermediate pipe. See **Figure 5**.

9. FOR ECMB, ECLB, CCSB & CCMB ONLY. Install a 3" clamp onto the Rear Intermediate pipe inlet. Install the Rear Intermediate pipe inlet into the Intermediate pipe outlet. Loosely tighten the clamp to secure the Rear Intermediate pipe.

ECMB, CCSB & CCMB SKIP TO STEP 11. ECLB CONTINUE TO STEP 10.

10. FOR ECLB ONLY. Install a 3" clamp onto the Intermediate Extension Pipe. Install the Intermediate Extension Pipe inlet into the Rear Intermediate Pipe outlet. **Skip to step 12.**

11. FOR ECMB, CCSB & CCMB ONLY. Install the 3" hanger clamp onto the Rear Intermediate Pipe. Install a 3" clamp onto the muffler inlet. Install the Banks Muffler inlet onto the Rear Intermediate Pipe outlet. Loosely tighten the 3" clamp to secure the Banks Muffler. Insert the hanger into to factory rubber hanger. **Skip to step 14.**

Figure 4

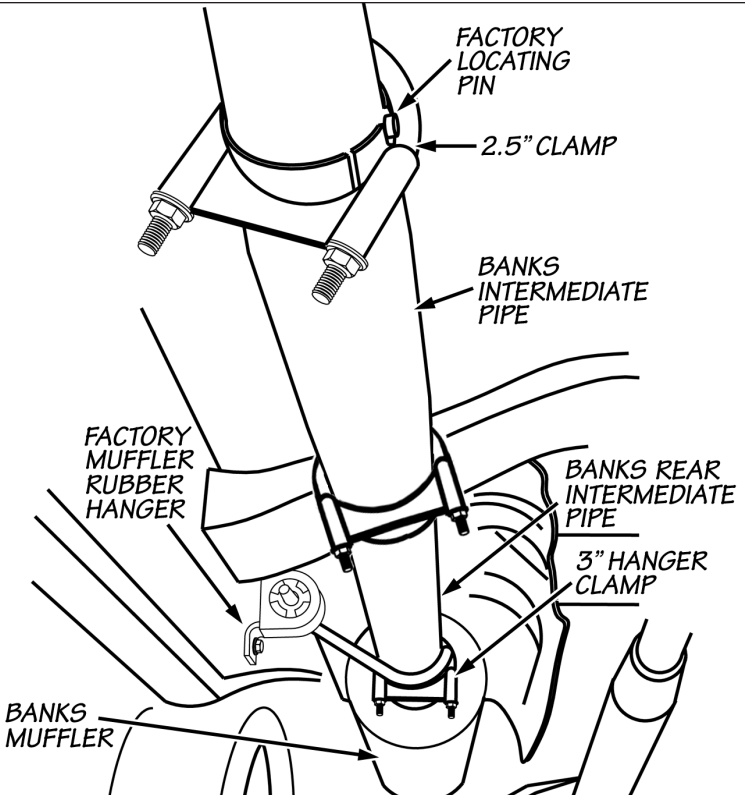
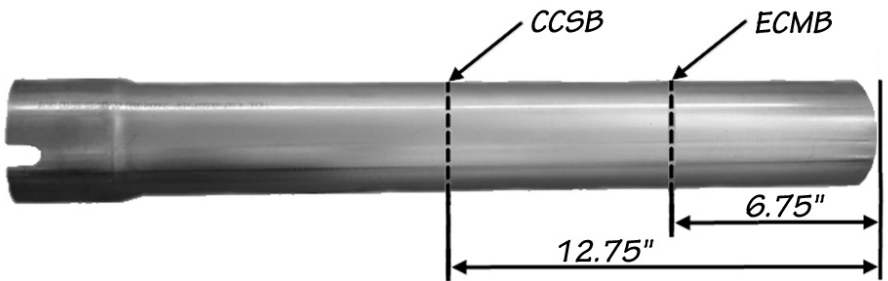

Figure 5- For CCSB & ECMB ONLY



12. For ECLB Only. Install the 3" hanger clamp onto the Intermediate Extension Pipe. Install a 3" clamp onto the muffler inlet. Install the Banks Muffler inlet onto the Intermediate Extension Pipe outlet. Loosely tighten the 3" clamp to secure the Banks Muffler. Insert the hanger into to factory rubber hanger. **Skip to step 14.**

13. For ECSB & SCMB Only. Install a 3" clamp onto the muffler inlet. Install the Banks Muffler inlet onto the intermediate pipe outlet. (Note the inlet labeling of the muffler) onto the intermediate pipe and lightly tighten the 3" clamp.

14. Install a 3" clamp on the Banks Muffler outlet. From the vehicle rear, route the Front Tailpipe over the rear axle. Start the Front Tailpipe hanger pin into the corresponding vehicle rubber hanger. Install the Front Tailpipe into the Banks Muffler Outlet (see **Figure 6**). Loosely tighten the 3" clamp to secure the Front Tailpipe.

15. Install a 3.5" clamp on the Front Tailpipe outlet. Start the Rear tailpipe hanger pin into the corresponding vehicle rubber hanger. Install the Rear Tailpipe into the Front Tailpipe outlet. Loosely tighten the 3.5" clamp to secure the Rear Tailpipe.

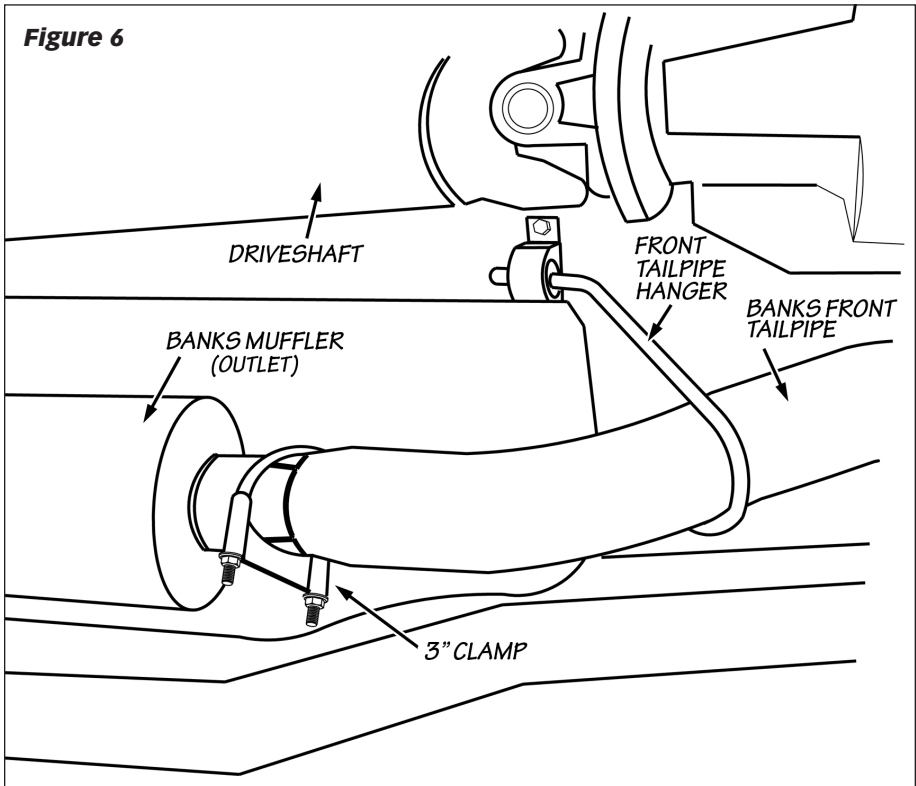

NOTE: Install the rubber hanger pins to the vehicle frame if previously removed.

16. Reinstall the two (2) factory M8x1.25 bolts through the rubber hanger into the vehicle frame. See **Figure 2**.

17. Install the supplied 3.5" band clamp over the inlet of the Monster tip. Install the tip onto the rear tailpipe. Loosely tighten the band clamp to secure the Monster Tip to the rear tailpipe.

18. Adjust the tip about 1/2"-1" under the body panel, such that the position is aesthetically pleasing.

19. With the exhaust positioned properly, begin to tighten the clamps and hardware starting with the ones closest to the front of the vehicle and working your way back. Torque the exhaust clamps evenly to 35 ft-lbs. Make sure that each slip is fully inserted (+/-1/4"). Torque the factory M8 hardware to 22 ft-lbs.

20. Remove the protective covering from the tailpipe tip.

CAUTION: The protective covering may ignite and burn if not removed prior to running the engine.

21. Your system includes two (2) "Banks Power" logos designed to complement the Ford emblems on the vehicles front fenders. Use the provided measurements for a clean factory look. See **Figure 7**.

22. Re-connect the negative battery cable. Start the engine and listen for exhaust leaks. Tighten the exhaust clamps as necessary. Whenever possible, tack weld slip connections to prevent disengagement is recommended. The Banks Monster Exhaust installation is now complete.

Figure 7

