

banks

with Installation Instructions
Owner's Manual

Banks Monster[®]
Exhaust System

1999-2006 Chevy/GMC 4.3L, 4.8L, 5.3L 1500

THIS MANUAL IS FOR USE WITH MONSTER EXHAUST SYSTEMS

48331, 48333, 48338

banks

Products available from Banks Power for the '99-06 Chevy/GMC 4.3/4.8/5.3L



Banks iQ System (P/N 61201)

- 5" touchscreen interface
- Interchangeable gauge display, read and clear codes, monitor engine diagnostics, log data, time your vehicles runs and much more.

Torque Tubes 4.8-5.3L (P/N 48004-48006)

- Virtually indestructible
- Each Torque Tube has a seamless high-velocity collector.
- Literally "pulls" out the exhaust, unleashing greater torque and helping the intake stroke to draw in more air.

Banks Ram-Air Intake System 4.8-5.3L (P/N 41800-41802)

- Increases your airflow over stock.
- Adds power, improves fuel economy, lowers EGTs and reduces smoke.

Banks AutoMind Programmer (P/N 66104)

- Clear and view OBDII Diagnostic Trouble Codes (DTC).
- Loaded with dyno-proven tuning files
- Speed Limiter adjustment capabilities
- Recalibration of the speedometer
- Customize and adjust gearing, tire size and fuel octane

General Installation Practices

1. Before starting work, familiarize yourself with the installation procedure by reading all of the instructions.
2. The exploded view (**Figure 1**) provides only general guidance. Refer to each step and section diagram in this manual for proper instruction.
3. Throughout this manual, the left side of the vehicle refers to the driver's side, and the right side to the passenger's side.
4. Disconnect the negative (ground) cable from the battery (or batteries, if there are two) before beginning work.

Tools Required:

- 1/2" and 3/8" drive ratchets with standard and metric sockets and 1/2" and 3/8" drive extension
- Standard and metric combination or open-end wrenches
- Standard screwdriver
- Clean shop towels or rags
- Pry-bar

5. Route and tie wires and hoses a minimum of 6" away from exhaust heat, moving parts and sharp edges. Clearance of 8" or more is recommended where possible.

6. When raising the vehicle, support it on properly weight-rated safety stands, ramps or a commercial hoist. Follow the manufacturer's safety precautions. Take care to balance the vehicle to prevent it from slipping or falling. When using ramps, be sure the front wheels are centered squarely on the topsides. When raising the front of the vehicle, put the transmission in park, set the parking brake, and block the rear wheels. When raising the back of the vehicle, be sure the vehicle is on level ground and the front wheels are blocked securely.

Caution! Do not use floor jacks to support the vehicle while working under it. Do not raise the vehicle onto concrete blocks, masonry or any other item not intended specifically for this use.

7. During installation, keep the work area clean. Do not allow anything to be dropped into intake, exhaust, or lubrication system components while performing the installation, as foreign objects will cause immediate engine damage upon start-up.

Highly recommended tools and supplies:

- Foot-pound torque wrench
- Penetrating oil or light lubricant spray

General Assembly

Figure 1

| Item # | Description | P/N | Qty |
|--------|---------------------------------------|-------|-----|
| *1 | Interm pipe SCSB (119 WB) | 53619 | 1 |
| *1a | Front, Interm Pipe ECSB/CCSB (143 WB) | 53622 | 1 |
| *1b | Rear, Interm Pipe ECSB/CCSB (143 WB) | 53623 | 1 |
| **2 | Front Muffler Hanger Clamp (99-02) | 53595 | 1 |
| **2 | Front Muffler Hanger Clamp (03-06) | 53608 | 1 |
| **2 | Front Muffler Hanger Clamp | 52465 | 1 |
| **3 | Monster Muffler | 54005 | 1 |
| **3 | Monster Muffler | 53962 | 1 |
| **4 | Rear Muffler Hanger Clamp (99-02) | 53596 | 1 |
| **4 | Rear Muffler Hanger Clamp (03-06) | 53609 | 1 |
| 5 | 3.5" Clamp | 52468 | 2 |

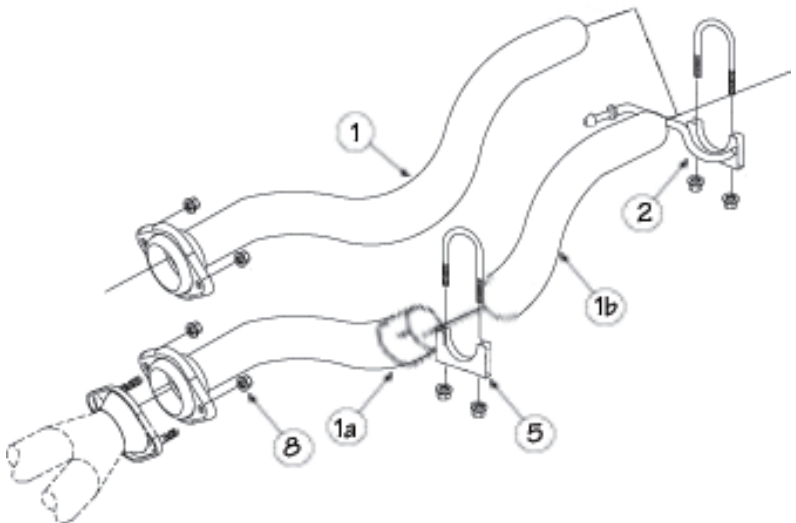

| Item # | Description | P/N | Qty |
|--------|-------------------------------|----------------|-----|
| **6a | Front, Tailpipe w/Tip (99-06) | 53611, 53598 | 1 |
| **6b | Rear, Tailpipe w/Tip (99-06) | 53621, 53599 | 1 |
| 7 | Banks Decals | 96009 | 2 |
| 8 | Factory 10mm Nuts | (Not Included) | |

* Wheelbase dependant

** year range and/or cab configuration dependant

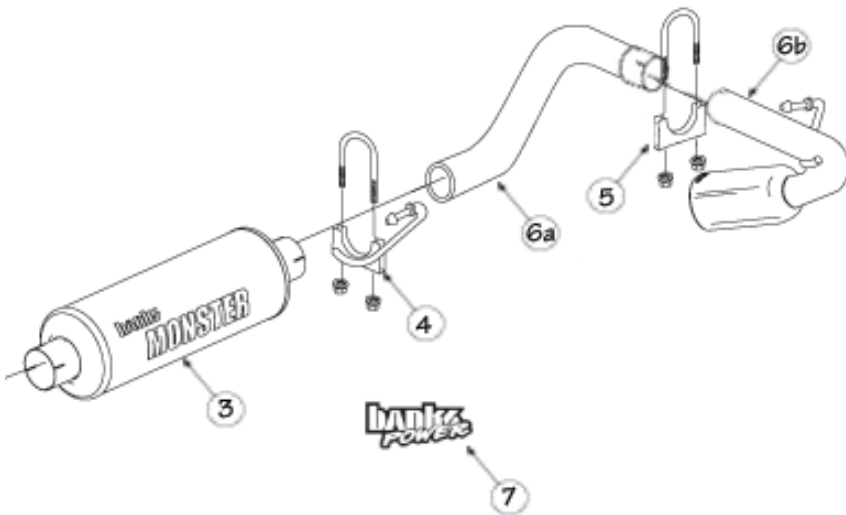

Monster Exhaust System Installation

1. Disconnect the negative (ground) cable from the battery (if there is more than one battery, disconnect both negative cables). Secure the cable so it cannot accidentally come in contact with the post.

2. Raise the vehicle and support it securely with properly weight-rated safety stands, ramps or a commercial hoist. Take care to balance the vehicle to prevent it from slipping or falling. When using ramps, be sure the wheels are centered squarely on the topsides. Place the transmission in park (automatic), set the parking brake and securely block the wheels that are on the ground.

CAUTION: DO NOT WORK UNDER ANY VEHICLE SUPPORTED ONLY BY A JACK. SEVERE INJURY MAY RESULT.

3. Loosen and remove the two (2) nuts on the 2-bolt flange, retain for reassembly. Remove the tailpipe hanger pin from the rubber hanger. Remove the rear muffler hanger pin from the rubber hanger. Remove the front muffler hanger pins from the rubber hangers.

NOTE: Spray lubricant may assist in hanger pin removal. Rubber hangers can also be removed from the vehicle to assist in tailpipe / muffler removal.

4. Remove the tailpipe, muffler and intermediate pipe assembly from the vehicle

For ECSB/CCSB skip to step 6.

5. For **SCSB ONLY:** Install the 2-bolt flange on the inlet of the Banks intermediate pipe to the factory flange. Loosely install the two (2) factory 10mm nuts onto the factory 2-bolt flange studs. Install the front hanger clamp onto the intermediate pipe outlet. Insert the hanger pin into the vehicles rubber hanger (see **Figure 2**).

For SCSB skip to step 7.

6. For **ECSB/CCSB:** Install the 2-bolt flange on the inlet of the Banks Front intermediate pipe to the factory flange. Loosely install the two (2) factory 10mm nuts onto the factory 2-bolt flange studs. Install a 3.5" clamp on the front intermediate pipe outlet. Install the Rear intermediate pipe into the Front intermediate pipe outlet. Loosely tighten the clamp to secure the Rear intermediate pipe. Install the front hanger clamp onto the Rear intermediate pipe outlet. Insert the hanger pin into the vehicles rubber hanger (see **Figure 2**).

7. Install the Monster Muffler inlet (Note the inlet labeling of the muffler) onto the intermediate pipe outlet. Orient the Monster logo such that is visible from the passenger side and parallel with the frame rail. Align the clamp onto the muffler inlet (see **Figure 2**).

NOTE: Once the pipe / muffler has been completely engaged in the slip joint, mark the pipe with a scribe or tape for reference when tightening the clamps later in the installation. Mark each slip joint in this fashion.

8. Install the rear muffler hanger clamp onto the Monster Muffler outlet. Insert the hanger pin into the vehicles rubber hanger (see **Figure 2**).

NOTE: All clamps should be positioned at the beginning of the slots (on the 1/2 circle punch).

9. From the vehicle rear, route the Front tailpipe over the rear end. Install the Front tailpipe into the Banks Muffler outlet. Lightly tighten the rear muffler hanger clamp to secure the Front tailpipe. Install a 3.5" clamp on the Front tailpipe outlet. Install the Rear tailpipe inlet onto the Front tailpipe outlet. Start the Rear tailpipe

Figure 2

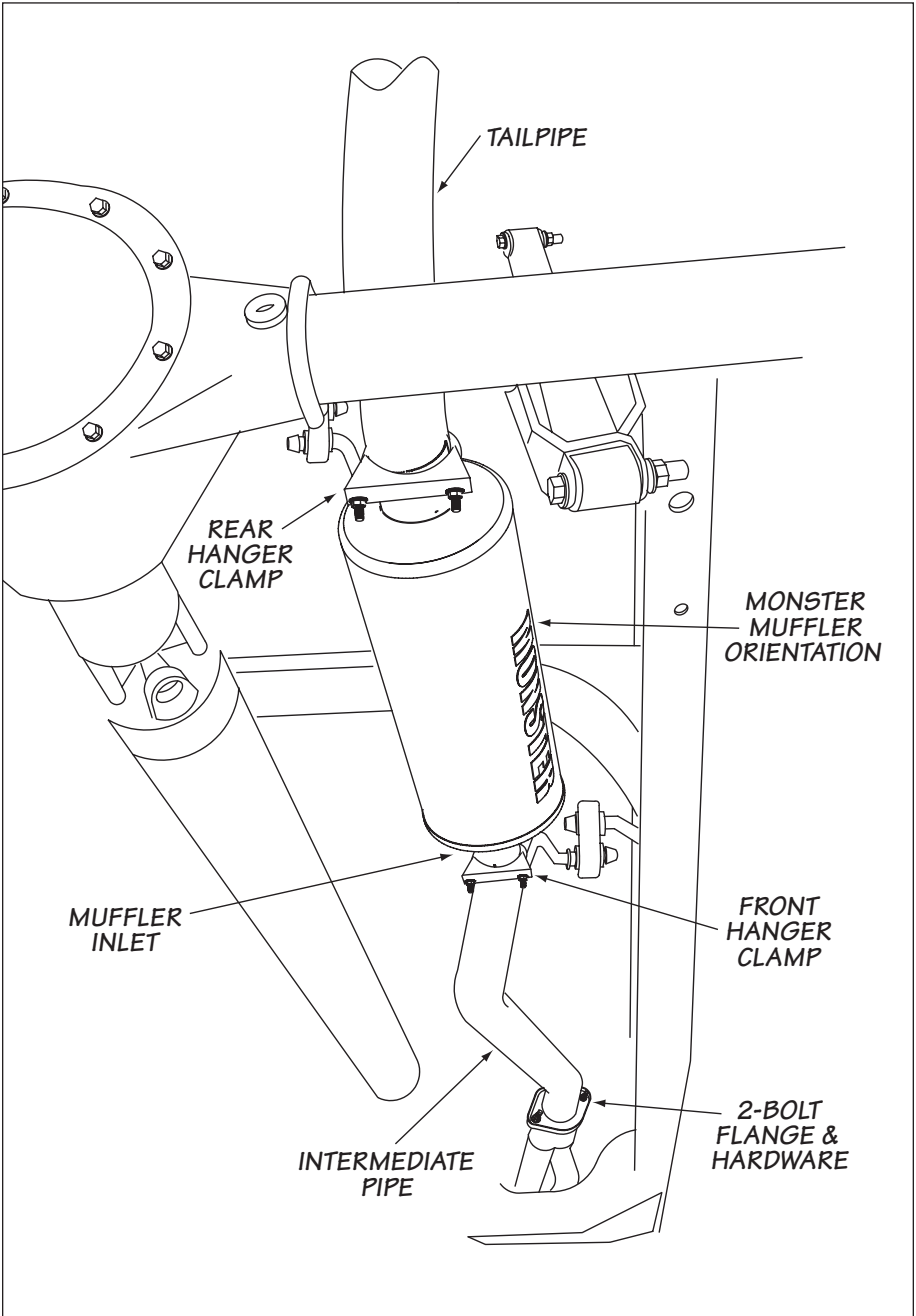
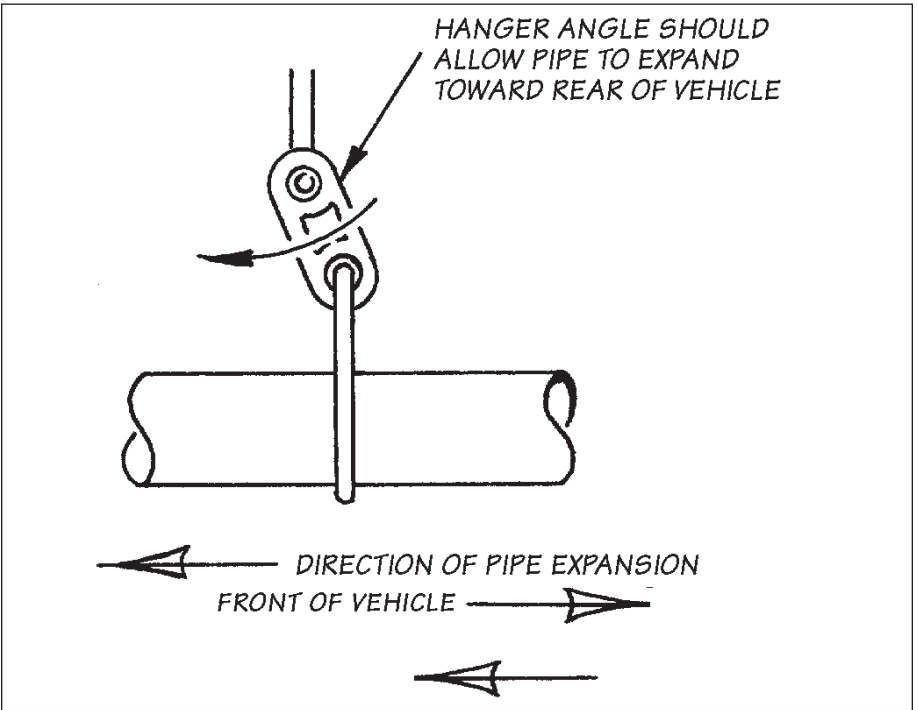

Figure 3



hanger pin into the corresponding vehicle rubber hanger. Loosely tighten the 3.5" clamp on the Front tailpipe outlet to secure the Rear tailpipe.

10. Adjust the tip about 1/2" under the body panel, such that the tip position is aesthetically pleasing.

11. Adjust each of the pipes to ensure that all of the hanger pins are parallel with the frame mounted pins and that the rubber hangers are all positioned slightly forward (See **Figure 3**). This allows the hangers to be properly positioned once the exhaust reaches operating temperature.

12. With the exhaust positioned properly, begin to evenly tighten the clamps starting with the ones closest to the front of the vehicle and working your way back. Torque the exhaust clamps evenly to 35 ft-lbs. Torque the 2-bolt flange, 10mm hardware to 40 ft-lbs. Make sure that each slip is fully inserted (+/-1/4").

13. Remove the protective covering from the tailpipe tip.

Caution: the protective covering may ignite and burn if not removed prior to running the engine.

Figure 4

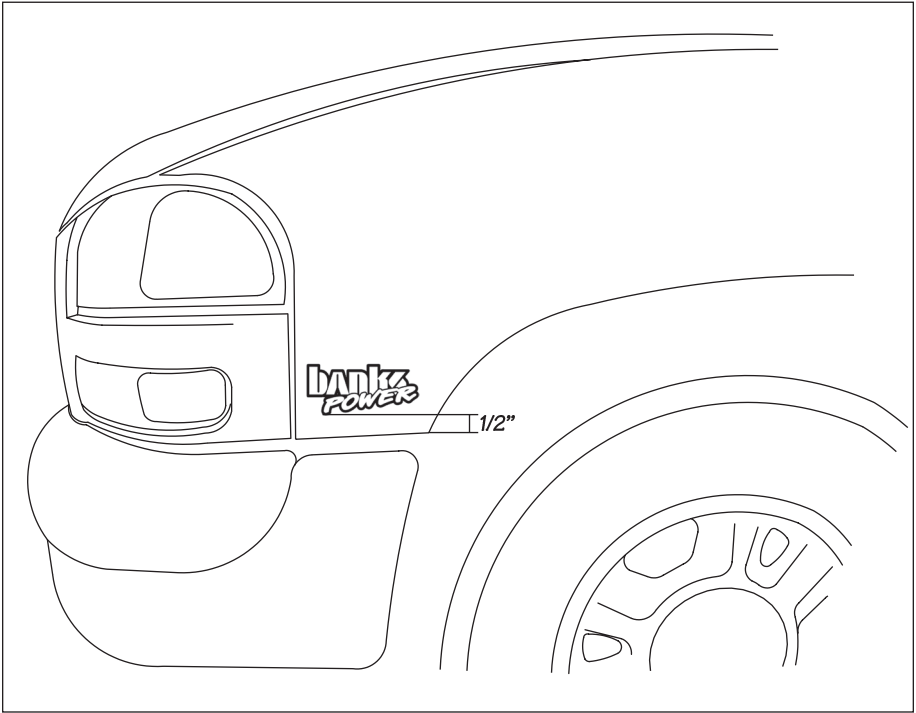

14. Your system includes two (2) Banks Power logos designed to complement the vehicle's front fenders. See **Figure 4** for recommended logo placement.

15. Re-connect the negative battery cable. Start the engine and listen for exhaust leaks. Tighten the exhaust clamps as necessary. Whenever possible, tack weld slip connections to prevent disengagement is recommended.

16. The Banks Monster Exhaust installation is now complete.