

banks

with Installation Instructions

Owner's Manual

Banks Monster[®] Exhaust System

2004-2014 Nissan Titan 5.6L

THIS MANUAL IS FOR USE WITH SYSTEMS 48120, 48122, 48123 & 48123-B

banks

General Installation Practices

1. Before starting work, familiarize yourself with the installation procedure by reading all of the instructions.
2. The exploded view (**Figure 1**) provides only general guidance. Refer to each step and section diagram in this manual for proper instruction.
3. Throughout this manual, the left side of the vehicle refers to the driver's side, and the right side to the passenger's side.
4. Disconnect the negative (ground) cable from the battery (or batteries, if there are two) before beginning work.

Tools Required:

- 1/2" and 3/8" drive ratchets with standard and metric sockets and 1/2" and 3/8" drive extension
- Standard and metric combination or open-end wrenches
- Standard screwdriver
- Clean shop towels or rags
- Pry-bar

5. Route and tie wires and hoses a minimum of 6" away from exhaust heat, moving parts and sharp edges. Clearance of 8" or more is recommended where possible.

6. When raising the vehicle, support it on properly weight-rated safety stands, ramps or a commercial hoist. Follow the manufacturer's safety precautions. Take care to balance the vehicle to prevent it from slipping or falling. When using ramps, be sure the front wheels are centered squarely on the topsides. When raising the front of the vehicle, put the transmission in park (automatic) or reverse (manual), set the parking brake, and block the rear wheels. When raising the back of the vehicle, be sure the vehicle is on level ground and the front wheels are blocked securely.

CAUTION! Do not use floor jacks to support the vehicle while working under it. Do not raise the vehicle onto concrete blocks, masonry or any other item not intended specifically for this use.

7. During installation, keep the work area clean. Do not allow anything to be dropped into intake, exhaust, or lubrication system components while performing the installation, as foreign objects will cause immediate engine damage upon start-up.

Highly recommended tools and supplies:

- Foot-pound torque wrench
- Penetrating oil or light lubricant spray

Also Available from Banks Power



Banks Ram-Air Intake System (P/N 41820)

- Increases your airflow over stock.
- Adds power, improves fuel economy, lowers EGTs and reduces smoke.

Banks AutoMind Programmer (P/N 66119)

- Clear and view OBDII Diagnostic Trouble Codes (DTC).
- Loaded with dyno-proven tuning files
- Speed Limiter adjustment capabilities
- Recalibration of the speedometer
- Customize and adjust gearing, tire size and fuel octane

Figure 1 General Assembly Diagram

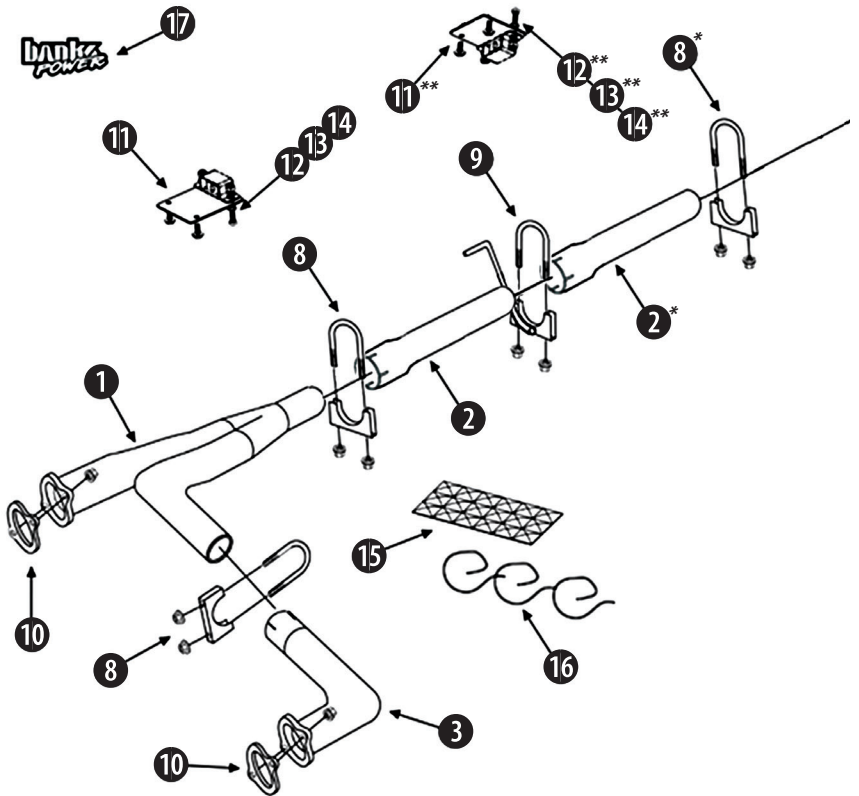

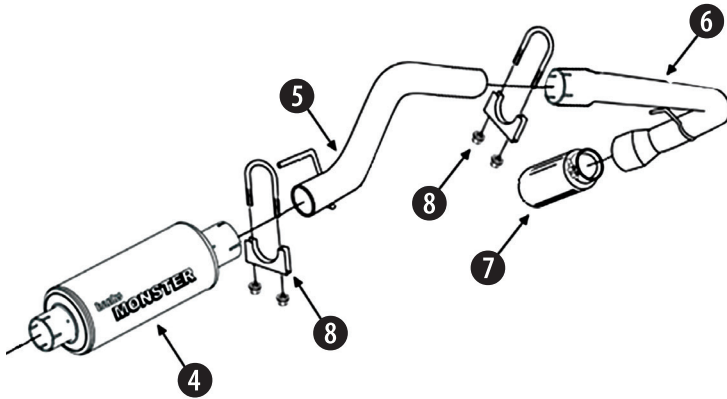

Item #	Description	P/N	QTY
1	Y-pipe Assembly	53957	1
2	Intermediate Pipe	53970	1 (2*)
3	Extension, Y-Pipe	53956	1
4	Muffler, 3" in/out	53962	1
5	Front, Tailpipe		1
6	Rear, Tailpipe		1
7	Tailpipe Tip, 4X5X12" Polished S.S.	52383	1
8	3" Exhaust Clamp	52465	4 (5*)
9	3" Hanger Clamp, Inter Pipe	53969	1
10	2-Bolt Gasket, Cat Converter	93095	2
11	Hanger Plate (Large Plate)	53961	1
	2009 Hanger Plate (Small Plate)	53972	(1**)
12	5/16" Washer, Flat SAE	91202	4 (8**)
13	5/16-18 Nut, Lock	91212	2 (4**)
14	5/16-18 x 3/4" Hex Bolt	91224	2 (4**)
15	Heatshield Blanket	26001	1
16	Tie 16", Heatshield Blanket	26013	3
17	Urocals, Bank Power	96009	2

* ONLY For Crew Cab Long Bed Models (System 48122)

** ONLY For System 48123

Monster Exhaust System Installation

1. Disconnect the negative (ground) cable from the battery (if there is more than one battery, disconnect both negative cables). Secure the cable so it cannot accidentally come in contact with the post.

2. Raise the vehicle and support it securely with properly weight-rated safety stands, ramps or a commercial hoist. Take care to balance the vehicle to prevent it from slipping or falling. When using ramps, be sure the wheels are centered squarely on the topsides. Place the transmission in park (automatic) or reverse (manual), set the parking brake and securely block the wheels that are on the ground.

CAUTION: DO NOT WORK UNDER ANY VEHICLE SUPPORTED ONLY BY A FLOOR JACK. SEVERE INJURY MAY RESULT.

WARNING! The following step may require the use of a torch and/or saw. Proper safety equipment should be used. Failure to use proper safety equipment may result in severe injury.

3. From under the vehicle remove the factory exhaust starting at the rear of the muffler. Remove the tailpipe by removing the two (2) nuts connecting the muffler to the tailpipe. Remove and retain the two (2) M8x1.25 bolts retaining the rubber hanger on the rear tailpipe hanger. Remove and retain the rubber hanger. Remove the tailpipe assembly from the vehicle (See **Figure 2**).

4. Remove the muffler and Y-pipe assembly by removing the four (4) M8x1.25 nuts from the studs of the two (2) flanges after the 3rd and 4th catalytic converters. Retain these four (4) nuts for reassembly (see **Figure 3**).

5. Remove and retain the two M8x1.25" factory bolts holding the factory Y-pipe rubber hanger and detach the rubber hanger. Remove the Y-pipe and muffler assembly.

6. Align the factory rubber hanger onto the Banks hanger plate and secure with the supplied 5/16" bolts, nuts and washers (see **Figure 4A**).

7. Align the hanger plate assembly onto the original location of the hanger such that the rubber hanger is on top of the plate. Loosely reinstall the two (2) factory bolts through hanger plate into the vehicle frame.

8. Install the two (2) gaskets onto the right and left side catalytic converter flanges. Install the Y-pipe flange onto the right side catalytic converter flange. Lightly tighten the factory two (2) M8x1.25 onto the factory studs.

9. Install a 3" clamp onto the left side headpipe outlet. Install the headpipe slip fitting onto the Y-pipe assembly. Install the headpipe flange onto the left side catalytic converter flange. Reinstall the ground strap onto the right factory stud and lightly tighten the two (2) factory M8x1.25 onto the factory studs (see **Figure 3**).

10. Install a 3" clamp into the inlet of the Intermediate pipe. Install the intermediate pipe onto the Y-pipe assembly. Lightly tighten the clamp to secure the intermediate pipe.

For Systems 48120 & 48123

Install the supplied 3" Hanger clamp into the inlet of the Banks Muffler. Start the hanger clamp pin into the corresponding vehicle rubber hanger. Install the Banks Muffler onto the outlet of the intermediate pipe. Verify the Muffler inlet is connected to the intermediate pipe.

Figure 2

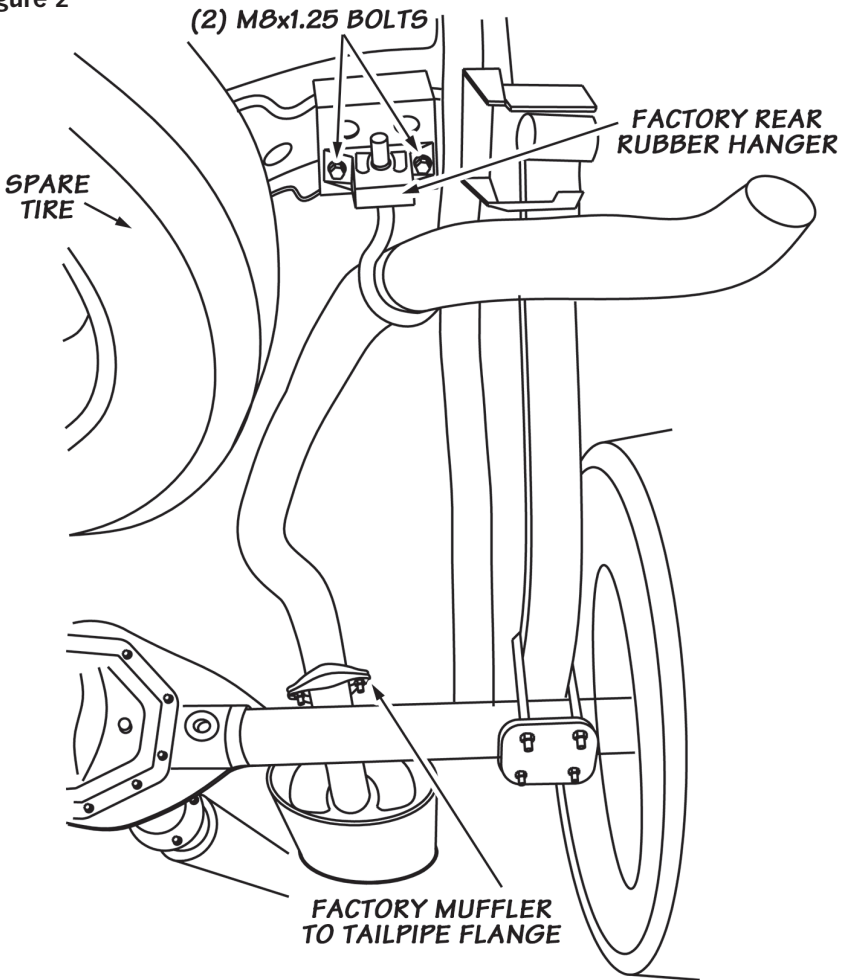

For System 48122

Install the supplied 3" Hanger clamp into the inlet of the second Intermediate pipe. Start the hanger clamp pin into the corresponding vehicle rubber hanger. Install the second intermediate pipe onto the outlet of the first intermediate pipe. Lightly tighten the hanger clamp.

11. For System 48122

Install a 3" clamp onto the inlet of the Banks Muffler. Install the Banks Muffler onto the outlet of the second intermediate pipe. Verify the Muffler inlet is connected to the intermediate pipe.

Figure 3

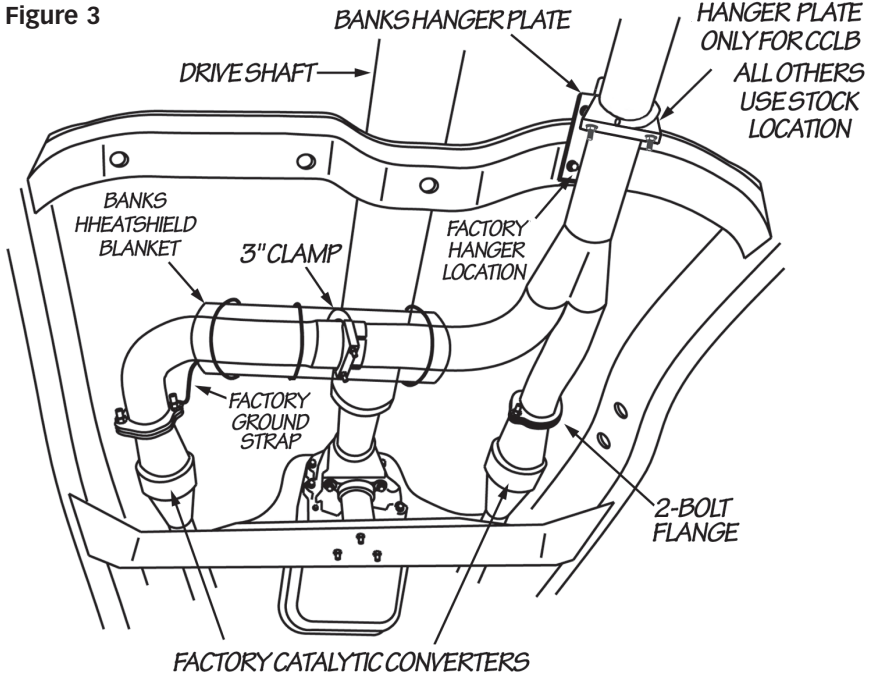
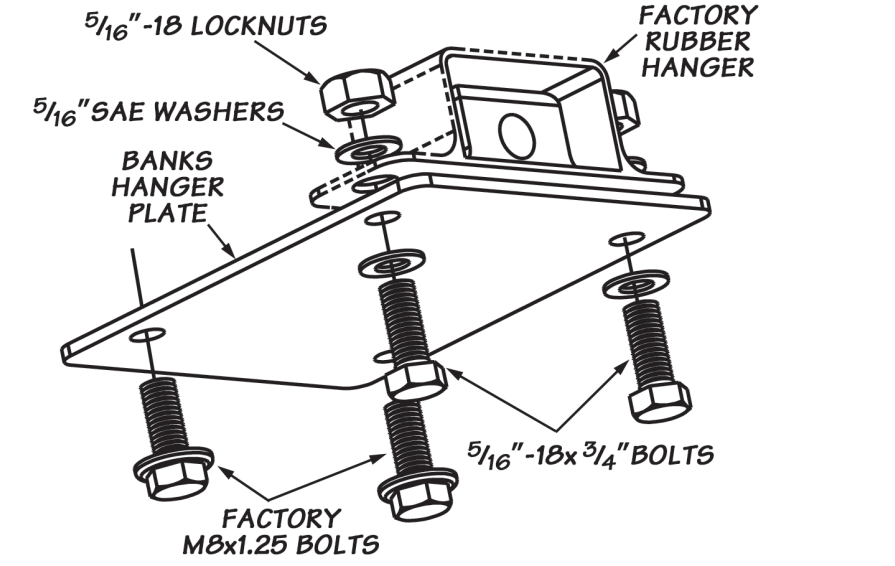

Figure 4A- 2004-2009 Models (Large Plate)



12. Install a 3" clamp on the Banks Muffler outlet. From the vehicle rear, route the front tailpipe over the rear end. Start the front tailpipe hanger pin into the corresponding vehicle rubber hanger. Install the front tailpipe into the Banks Muffler. Install a 3" clamp on the front tailpipe outlet. Install the rear tailpipe into the front tailpipe outlet.

For systems 48120 & 48122

Start the Rear tailpipe hanger pin into the corresponding vehicle rubber hanger.

For systems 48120 & 48122 skip to step 15

Steps 13-14 Are For the Installation of System 48123

13. Align the factory rubber hanger onto the Banks hanger plate (53972) and secure with the supplied $\frac{5}{16}$ " bolts, nuts and washers (see **Figure 4B**).

14. Align the hanger plate assembly onto the original location of the hanger such that the rubber hanger is below the plate and rear of the original location. Loosely reinstall the two (2) factory bolts through hanger plate into the vehicle frame.

15. Install the factory rubber hanger onto the rear tailpipe hanger pin. Reinstall the two (2) M8x1.25 bolts through the rubber hanger into the vehicle frame.

16. Keep the wrapping on the tailpipe tip until installation is complete. Adjust the tip about $\frac{3}{4}$ " under the body panel, inline with the vehicle body, such that the position is aesthetically pleasing.

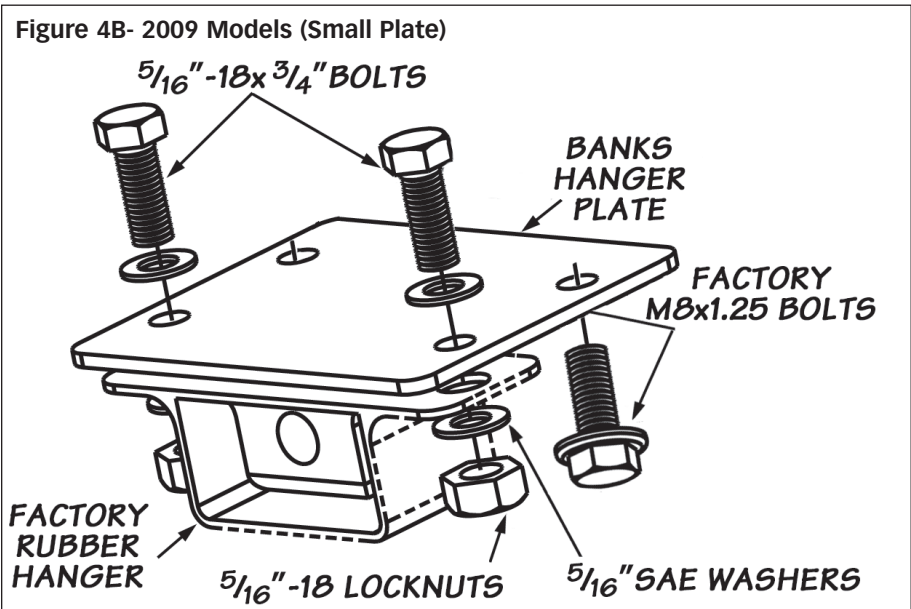

Figure 5

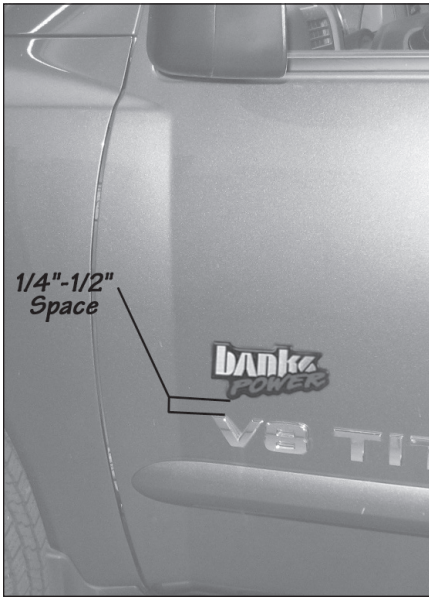

Figure 6



17. With the exhaust positioned properly, begin to tighten the clamps and hardware starting with the ones closest to the front of the vehicle and working your way back. Torque the exhaust clamps evenly to 35 ft-lbs. Make sure that each slip is fully inserted (+/- 1/2"). Torque the factory M8 hardware to 22 ft-lbs. Torque the 5/16" hardware to 19 ft-lbs.

18. Install the supplied heatshield blanket onto the y-pipe and left head pipe connection. Wrap the heatshield around the clamp and pipes to protect your transfer case or gas tank (if applicable). Secure wrapping with the three (3) tie wraps (see **Figure 3**).

19. Remove the protective covering from the tailpipe tip.

CAUTION: the protective covering may ignite and burn if not removed prior to running the engine.

20. Your system includes two (2) "Banks Power" logos designed to complement the Nissan emblems on the vehicles front fenders (see **Figures 5 and 6**).

21. Re-connect the negative battery cable. Start the engine and listen for exhaust leaks. Tighten the exhaust clamps as necessary. Whenever possible, tack weld slip connections to prevent disengagement is recommended.

22. The Banks Monster Exhaust installation is now complete.

2008 Nissan Titan 5.6L Monster Exhaust System

