

banks[®]

Owner's Manual with Installation Instructions

Banks Power Pack[®] /Stinger[®] System

**Compatible with Optional Banks iQ[™]
2003-2007 Ford Power Stroke 6.0L
Turbo-Diesel Pickups**

THIS MANUAL IS FOR USE WITH SYSTEM 63743, 63745, 63747 & 63748

banks

Also Available from Banks Power



Banks iQ System (P/N 61151-61152)

- 5" touchscreen interface that can control the Banks Diesel Tuner and/or SpeedBrake on the fly.
- Interchangable gauge display, read and clear codes, monitor engine diagnostics, log data, time your vehicles runs and much more.

Banks Monster® Exhaust System

**Sport (P/N 48790-48793)
Single and Dual (P/N 47285-47292, 47606-47609, 48783-48788)**

- Increases exhaust flow, cuts backpressure, lowers exhaust gas temperatures (EGTs) and increases power.

Banks Ram-Air Intake System (P/N 42155)

- Increases your airflow over stock.
- Adds power, improves fuel economy, lowers EGTs and reduces smoke.

High-Ram Intake (P/N 42750-42751)

- Increases flow and provides more uniform air distribution to the engine for more available power at a given boost level.

Banks Techni-Cooler® System (P/N 25974-25975)

- Provides increased air flow to the engine by increasing air density for more increased power, lower EGTs and improved fuel economy.

Banks Brake (P/N 55467-55468)

- Increases the stopping power of your truck and extends the service life of your brakes

Banks Billet Torque Converter (P/N 72522)

- Higher torque capacity over stock
- Lockup clutch is slip-resistant so transmission fluids stay cooler and transmission life is prolonged.

Banks SpeedBrake iQ Compatible (P/N 55455-55456)

PDA Compatible (P/N 55457-55458)

- Allows for controlled hill decent at a user defined vehicle speed.

**Boost and Pyro Gauges
(P/N 64507)**

- Keep your engine safe by monitoring vital engine parameters

**Banks Bullet
(P/N 66524-66525)**

- Adds power safely to your vehicle
- Displays critical engine functions
- Engine safeguards
- Change power levels on-the-fly

**Banks Diesel Tuner
Six-Gun w/ switch (P/N 61023)**

**Six-Gun w/ iQ (P/N 63749)
EconoMind w/ switch (P/N
63743-63745)**

**EconoMind w/ iQ (P/N 63747-
63748)**

- Adds power safely to your vehicle
- Engine and transmission safe guards
- Change power levels on-the-fly

**Banks Speed-Loader
(P/N 62988)**

- Furthers the power output of the Banks Six-Gun and provides EGT limiting safety.

Thermocouple

- Add a temperature limiting function to your Diesel Tuner

**OttoMind Programmer
(P/N 66064)**

- Contains Banks tunes that boost your vehicles HP, Torque and MPG.
- Displays a host of critical engine functions
- Provides "service technician" diagnostic capabilities
- Has upgradeable functionality, so it will never be out of date

**Banks Stinger Systems
(P/N 46465-46486)**

Contains:

- Ram-Air Intake system
- Monster Exhaust (single or dual)
- EconoMind Tuner w/ Banks iQ

**Banks PowerPack Systems
(P/N 46497-46519)**

Contains:

- Ram-Air Intake system
- Monster Exhaust (single or dual)
- EconoMind Tuner w/ Banks iQ
- High-Ram
- Techni-Cooler System

**Banks Six-Gun Bundle
(P/N 46594-46613)**

Contains:

- Ram-Air Intake system
- Monster Exhaust (single or dual)
- Six-Gun Tuner w/ Banks iQ

**Banks Big Hoss Bundle
(P/N 46623-46643)**

Contains:

- Ram-Air Intake system
- Monster Exhaust (single or dual)
- Six-Gun Tuner w/ Banks iQ
- Big Head Wastegate Actuator
- High-Ram
- Techni-Cooler System

General Installation Practices

Dear Customer, If you have any questions concerning the installation of your Banks EconoMind Diesel Tuner, please call our Technical Service Hotline. If you have any questions relating to shipping or billing, please contact our Customer Service Department.

Thank you.

1. For ease of installation of your Banks system, familiarize yourself with the procedure by reading the entire manual before starting work. This manual contains **42** pages of copy, illustrations and parts listing. If any pages are missing from this manual please call Gale Banks Engineering immediately for a replacement.
2. The exploded illustrations provide only general guidance. Refer to each step and section diagram in this manual for proper instruction.

3. Throughout this manual, the left side of the vehicle refers to the driver's side, and the right-side to the passenger's side.
4. Disconnect the ground cable from the battery before beginning work. If there are two batteries, disconnect both.
5. Route and tie wires and hoses a minimum of 6 inches away from exhaust heat, moving parts and sharp edges. Clearance of 8 inches or more is recommended where possible.
6. During installation, keep the work area clean. If foreign debris is transferred to any Banks system component, clean it thoroughly before installing.
7. When raising the vehicle, support it on properly weight-rated safety stands, ramps or a commercial hoist. Follow the manufacturer's safety precautions. Take care to balance the vehicle to prevent it from slipping or falling. When using ramps, be sure the front wheels are centered squarely on the topsides; put the transmission in park; set the parking brake; and place blocks behind the rear wheels.

Caution! Do not use floor jacks to support the vehicle while working under it. Do not raise the vehicle onto concrete blocks, masonry or any other item not intended specifically for this use.

Warning: Below 32°F (0°C) or above 140°F (60°C), the Banks iQ may be susceptible to damage as a result of extended direct exposure to sunlight, heat or extreme cold. It is highly recommended that Banks iQ be removed from its mounting location if the vehicle will be subjected to high concentrations of sunlight, heat or cold for an extended period of time. Gale Banks Engineering is not responsible for damage to Banks iQ resulting from exposure conditions.

Tools Required:

- 1/4" and 3/8" drive ratchets
- Inch and metric deep sockets
- Ratchet extension
- Metric combination or open-end wrenches
- Phillips and flat blade screwdrivers
- Standard and needle-nose pliers
- Pocket or X-Acto knife
- Clean shop towels or rags
- Drill bit set
- Drill motor
- Tap Handle
- 1/4" NPT tap
- 5/16 nut driver
- Pliers
- Torx bits
- Pry-bar

Highly recommended tools and supplies:

- Multimeter or 12-volt test light
- Heat gun
- Foot-pound torque wrench
- Penetrating oil or light lubricant spray
- Reciprocating saw
- Inch-pound torque wrench

Table of Contents

General Installation Practices	4
Banks Powerpack System	
Section 1	8
Installation of Banks Monster Exhaust System	
Section 2	16
Techni-Cooler Assembly Installation	
Section 3	23
Thermocouple Installation	
Section 4	24
Banks EconoMind Diesel Tuner Installation	
Section 5	29
Mounting and Connecting the Banks iQ	
Section 6	32
Installation of the Power Level Selector Switch	
Section 7	34
OPTIONAL Gauge Cluster Installation	
Section 8	35
Automatic Transmission Learning	
Section 9	35
Troubleshooting, EconoMind	
Section 10	38
Removal of the EconoMind Diesel Tuner	
Section 11	38
Placement of the Banks Power Decal	

General Assembly Diagram

BANKS POWERPACK SYSTEM

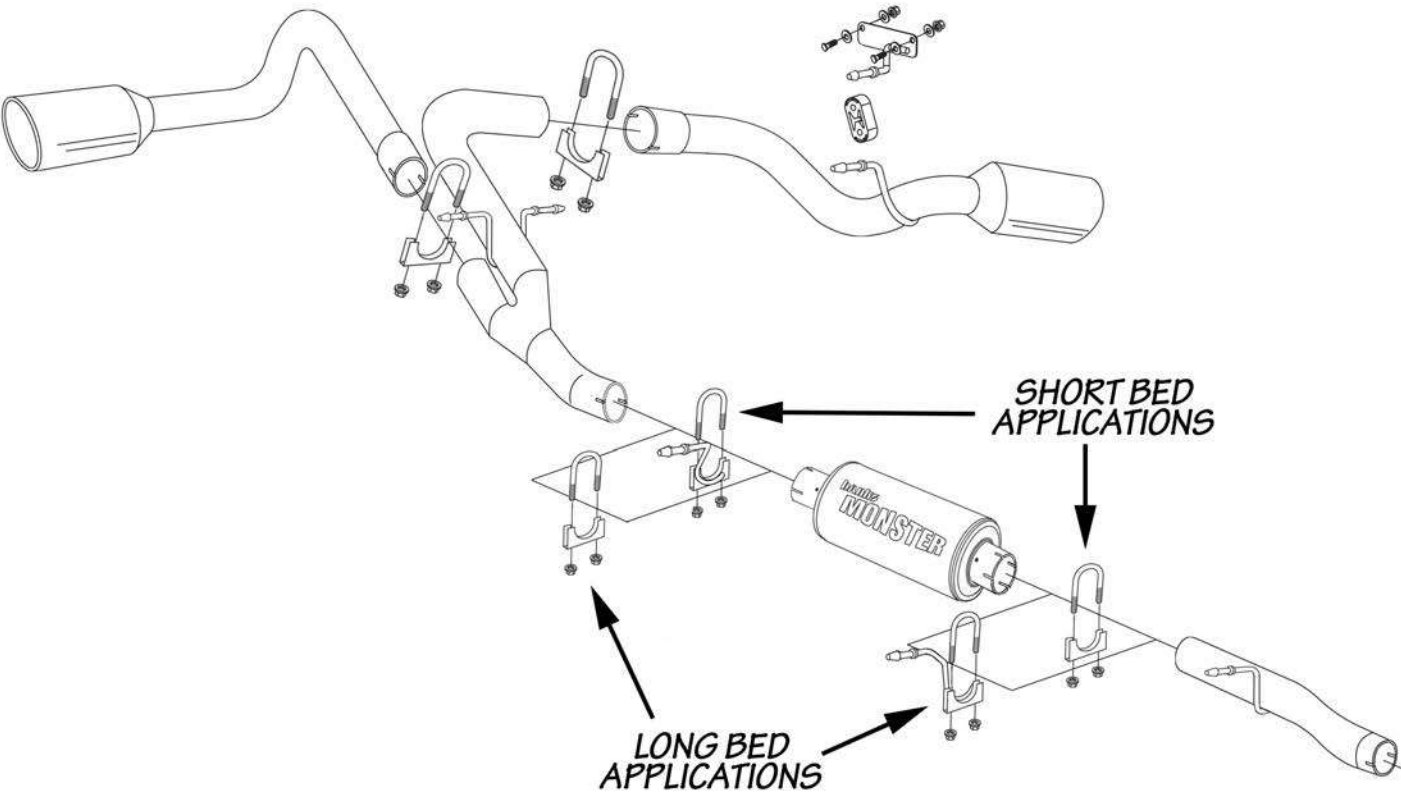

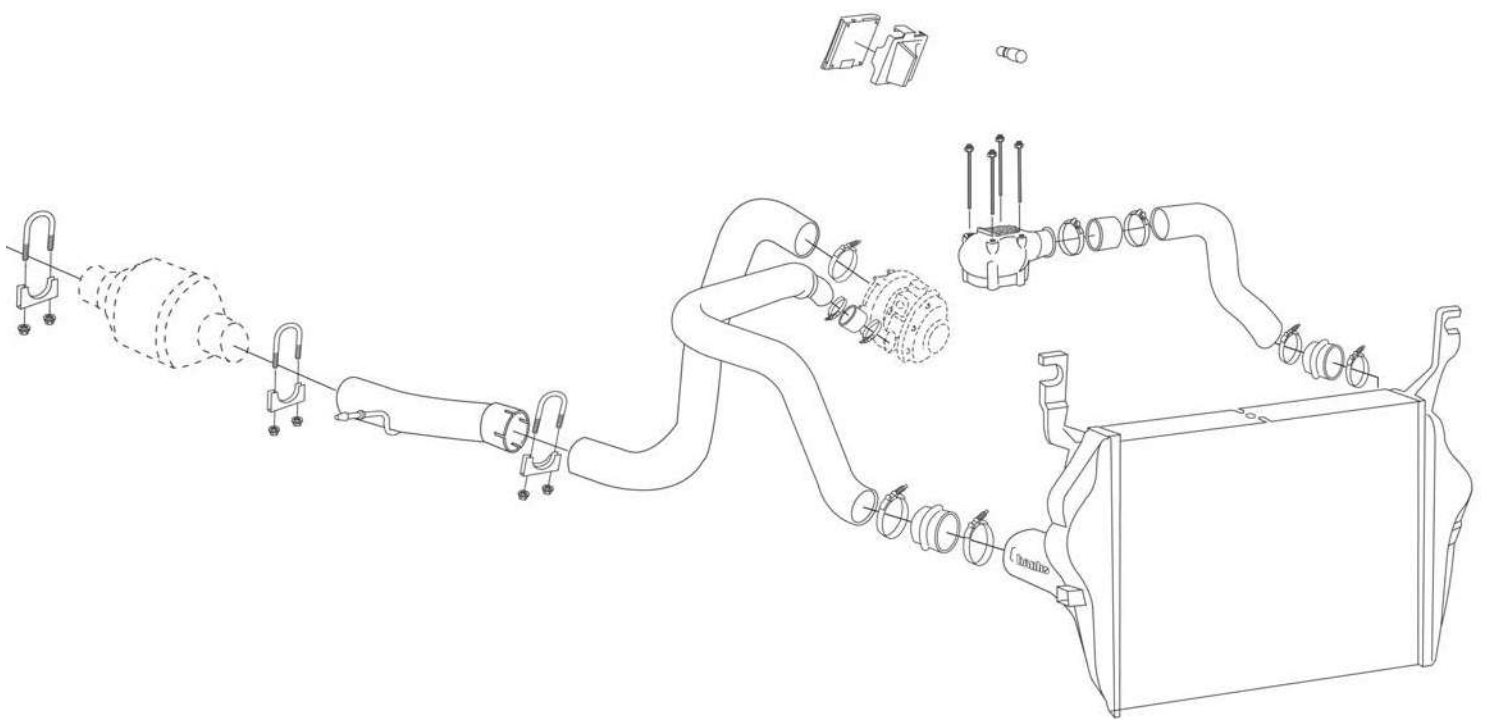

Section 1

INSTALLATION OF BANKS MONSTER EXHAUST SYSTEM

Figure 1a
General Assembly
Banks Monster Exhaust (Single Tailpipe)

	Description	Part #	Qty.
1	Banks Monster Muffler	53800	1
2	Turbine Outlet Pipe		
	2003 (T.O.P.) w/ Resonator	53525	1
	2004-2007 (T.O.P.) w/o Resonator	53537	1
3	Front Intermediate Pipe	53526	1
4	Rear Intermediate Pipe		
	Crew-Cab Long-bed / Crew-Cab Short-Bed	53529	1
	Rear Intermediate Pipe (Extended-Cab Long-Bed)	53530	1
	Rear Intermediate Pipe (Extended-Cab Short-Bed)	53528	1
	Rear Intermediate Pipe (Regular-Cab Long-Bed)	53527	1
	Rear Intermediate Pipe (Excursion)	53534	1
5	Extension Pipe (Crew-Cab Long-Bed)	53531	1
6	Monster Tailpipe		
	(Truck)	53512	1
	(Excursion)	53536	1
7	Polished 5" Exhaust Tip	52383	1
8	Exhaust Clamp, 4" (Crew-Cab Long-Bed contains 2 clamps)	52470	1
9	Exhaust Clamp, 3 1/2"	52468	2
10	Hanger Clamp, Front, Muffler		
	(Truck)	53453	1
	(Excursion)	53498	1
11	Hanger Clamp, Rear, Muffler		
	(Truck)	53454	1
	(Excursion)	53499	1
12	Hanger Pin Assembly (Crew-Cab Short-Bed)	53532	1
13	Spacers, 8mm (Long-Bed)	91019	2
14	Bolt, 8-1.25x30mm (Crew-Cab Short-Bed)	91788	2
15	Washer, Flat, 5/16" (Crew-Cab Short-Bed)	91202	2
16	Nut, Lock, 8-1.25mm (Crew-Cab Short-Bed)	91803	2

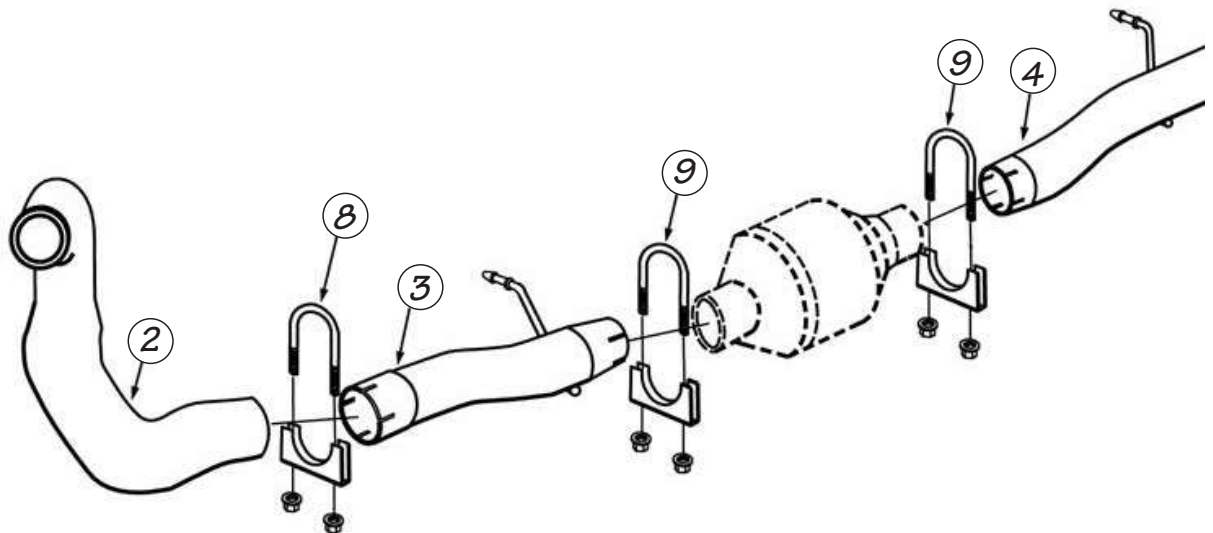

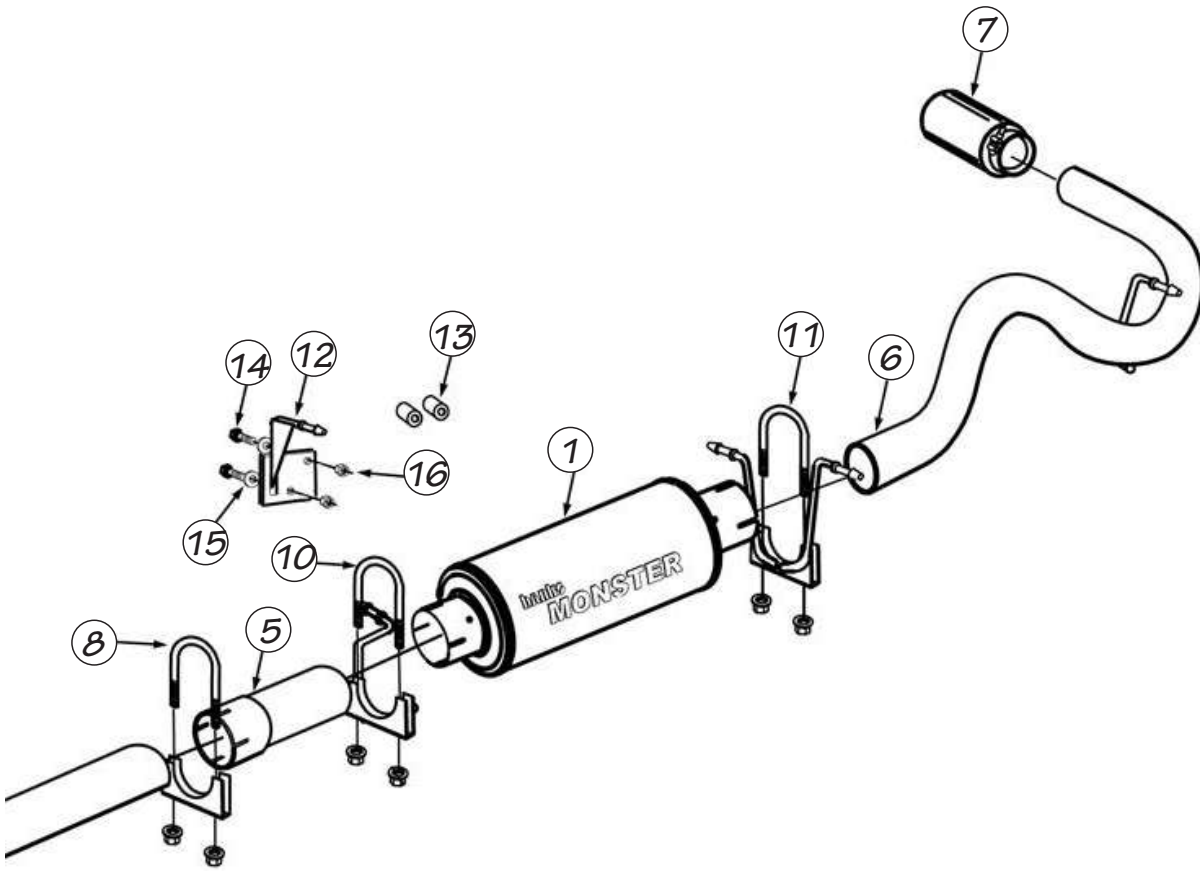
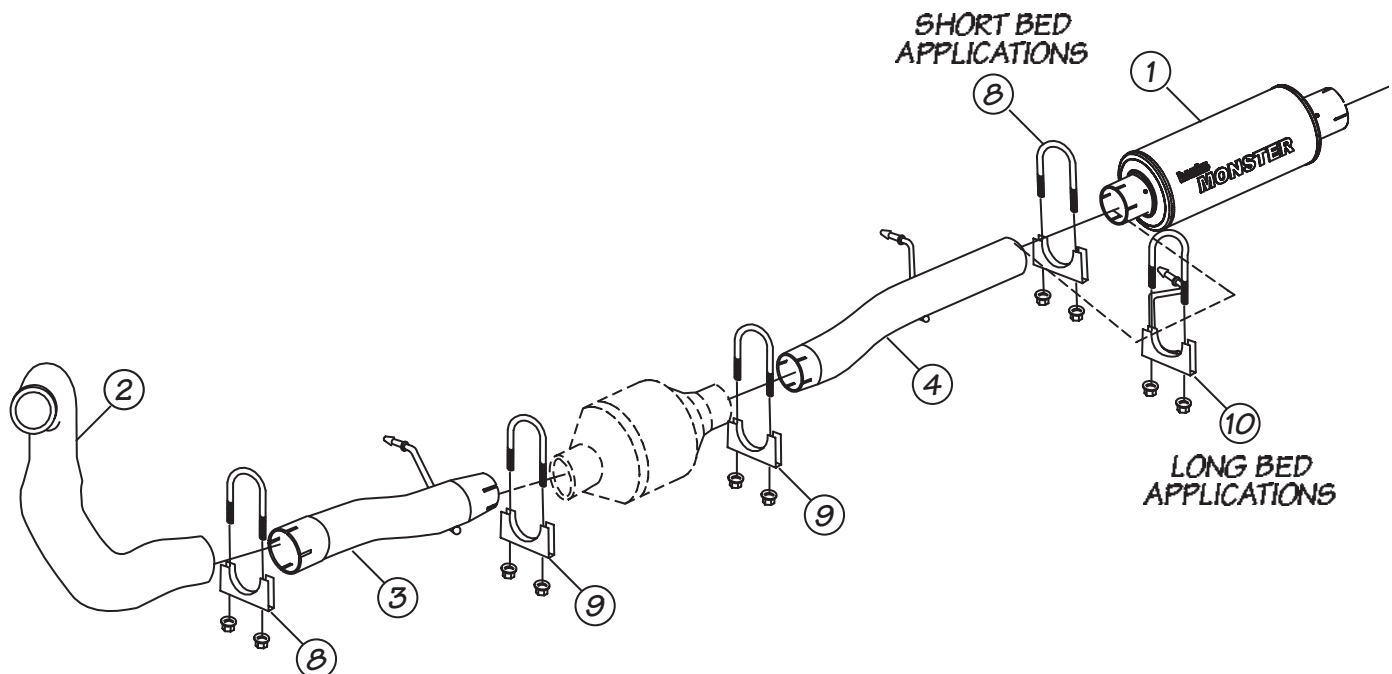
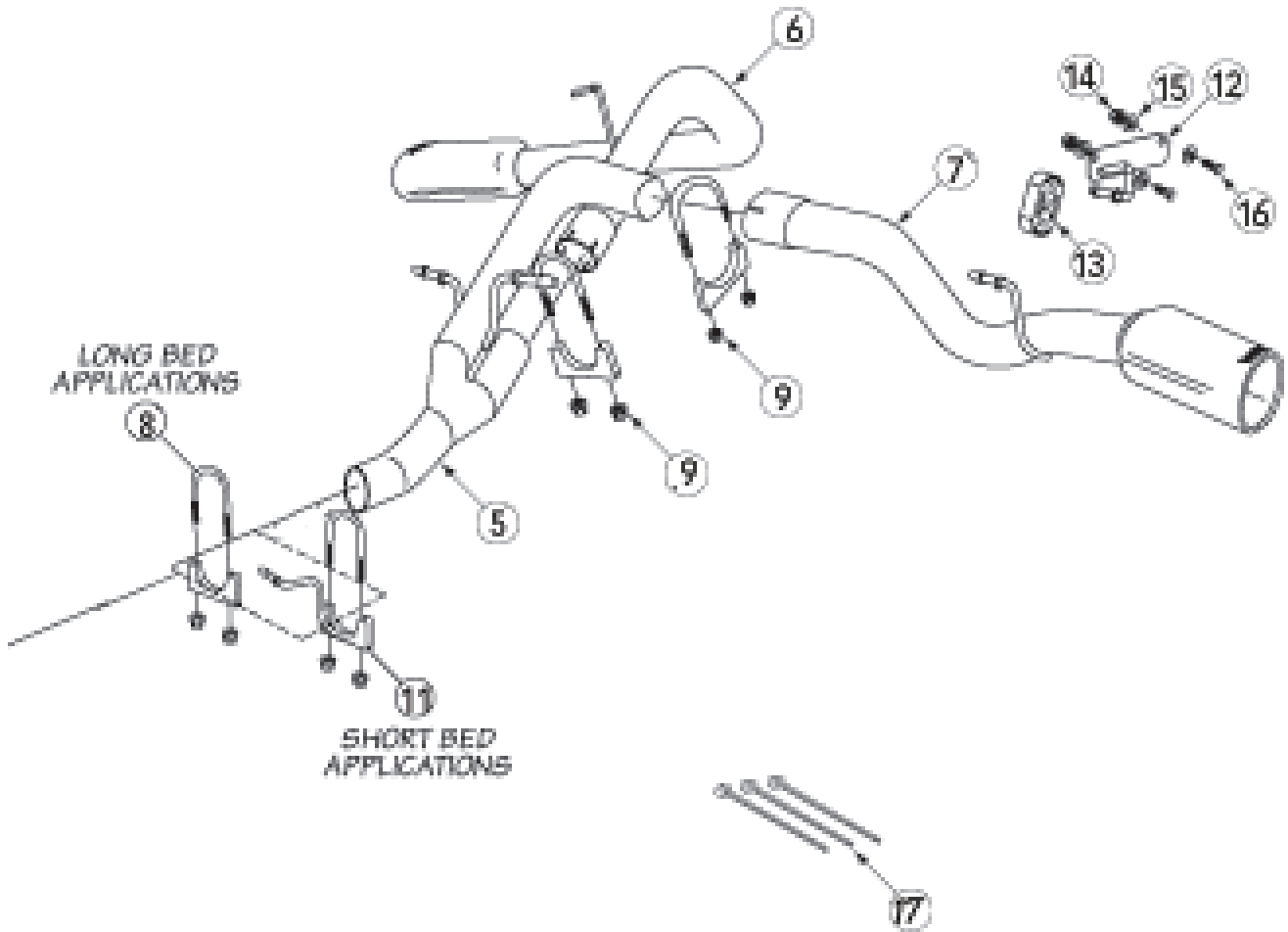

Figure 1b
 General Assembly
Banks Monster Exhaust, Split-Dual

Description	Part #	Qty.
1 Banks Monster Muffler	53800	1
2 Turbine Outlet Pipe (T.O.P.)		
2003 w/ Resonator	53525	1
2004-07 w/o Resonator	53537	1
3 Front Intermediate Pipe	53526	1
4 Rear Intermediate Pipe		
(Crew-Cab Short-Bed)	53557	1
(Extended-Cab Long-Bed)	53558	1
(Extended-Cab Short-Bed)	53556	1
(Crew-Cab Long-bed)	53559	1
5 Y-Pipe		
2003-2007	53574	1
6 Monster Tailpipe Pass. Side,		
2003-2007	53575	1
7 Monster Tailpipe Drvr. Side,		
2003-2007	53576	1
8 Exhaust Clamp, 4"	52476	2
9 Exhaust Clamp, 3 1/2"	52468	4
10 Hanger Clamp, Front, Muffler	53453	1
11 Hanger Clamp, Rear, Muffler	53455	1
12 Frame Hanger Bracket	53566	1
13 Rubber Insulator	53732	1
14 Nut, Nylock, 7/16-20	91617	2
15 Washer, SAE, 7/16"	91603	4
16 Bolt, 7/16-20 x 1	91627	2
17 Cable Tie, Black 5"	62001	3





Exhaust System Installation

Use the Bill of Materials Chart and **Figure 1a** or **1b** reference component nomenclature and location. Use caution when working in the engine compartment. Make sure the engine has been off for several hours and is cool.

1. Disconnect the battery ground cables from each of the batteries. Secure the cables so that they do not come in contact with the battery posts.
2. Remove the (+) battery cable from the driver side battery.
3. Remove the driver side plastic battery cover. This is accomplished by depressing a tab at the front and rear of the cover. Be careful not to damage the cover, as it will be re-installed.
4. Remove the driver side battery hold down clamp (8mm socket).
5. Remove the driver side battery.

WARNING: When lifting a battery, excessive pressure on the end walls could cause acid to spew through the vent caps, resulting in personal injury. Lift with a battery carrier or with hands on opposite corners. Failure to follow these instructions may result in personal injury.

6. Raise the vehicle and support it securely with properly weight-rated safety stands, ramps or a commercial hoist. Take care to balance the vehicle to prevent it from slipping or falling. When using ramps, be sure the wheels are centered squarely on the topsides. Place the transmission in park (automatic) or reverse (manual), set the parking brake and securely block the wheels that are on the ground.

CAUTION: DO NOT WORK UNDER ANY VEHICLE SUPPORTED ONLY BY A JACK. SEVERE INJURY MAY RESULT.

WARNING! The following step may require the use of a torch and/ or saw. Proper safety equipment should be used. Failure to use proper safety equipment may result in severe injury.

7. From under the vehicle remove the factory exhaust system from the catalytic converter back. Starting at the rear of the vehicle, remove each component by either cutting through the pipe near the clamps or

by removing the clamps and heating the joints with an oxyacetylene torch to allow crimped pipes to separate. DO NOT CUT OR DAMAGE CATALYTIC CONVERTER TUBING DURING THE REMOVAL PROCESS. To assist in removal, the T.O.P. should be cut before the transmission if it is going to be replaced. Remove the hanger pins from the rubber hangers with a pry bar. (Spray lubricant will ease hanger removal.)

8. Remove the two (2) nuts attaching the turbine outlet pipe (T.O.P.) to the catalytic converter inlet. Loosen and remove the band clamp that attaches the rear intermediate pipe to the catalytic converter outlet. Remove the catalytic converter assembly from the vehicle. Remove the v-band-clamp that attaches the T.O.P. to the turbocharger and remove the factory T.O.P. from the vehicle. Retain V-band clamp for re-assembly.

Note: To assist in T.O.P. removal, remove the rear engine hoist hook by removing the two (2) Hex screws and remove the valve cover heat shield. The dipstick tube may also be removed or slightly bent to allow for T.O.P. removal/installation. Retain all hardware and parts for reassembly.

9. For Manual Transmissions only: The transmission will need to be lowered to allow for removal and installation of the T.O.P. Using a Transmission Jack, support the rear of the transmission to allow working room for the T.O.P. and remove the rear transmission mount and cross member. Remove the Front drive shaft support bracket from the cab. Lower the transmission 4-6" and remove the factory T.O.P. The transmission may need to be raised before the Banks T.O.P. is installed. Install the Banks T.O.P. Raise the transmission and reinstall drive shaft bracket, transmission cross member and rear transmission mount. Refer to vehicles owners manual for factory Torque Specifications.

10. Loosely place the factory V-band clamp on the Banks T.O.P. Install the Banks T.O.P. to the turbine housing. Loosely snug the V-band clamp assuring the T.O.P. is aligned properly.

Note: Reinstall the engine hoist hook and valve cover heat shield if previously removed.

11. The catalytic converter inlet will need to be trimmed to accommodate the Banks exhaust system. Be careful

not to trim an excessive amount of tubing. Be sure to wear proper safety equipment.

IMPORTANT: Diesel catalysts may become plugged with soot, which can restrict exhaust flow, impeding performance. Inspect the converter by shining a powerful flashlight into the inlet. Observe the light through the other end of the converter. The full circle of the flashlight should be visible without any blockage in the grid work of the catalyst. If excessive soot is observed, the catalyst may need to be cleaned. TAKE PRECAUTIONS to avoid blowing soot toward the work area or where it could be inhaled. ALWAYS use breathing protection. Also inspect the catalyst for damage (i.e. chips, bent corners, etc.) to the grid work. If your catalytic converter is damaged, it may be covered under your vehicle's emissions warranty.

12. With the catalytic converter removed from the vehicle and the head pipe removed from the converter, measure approximately 4" from the weld and mark the location (this location should be before any bend, about 7" rear of the inlet flange). Using a reciprocating saw or equivalent, vertically cut and remove 7" from the converter inlet tubing. Make sure cut is square (see **Figure 2**).

13. Install the supplied Banks front intermediate pipe onto the previously installed Banks T.O.P. Loosely install a supplied 4" exhaust clamp onto the forward end of the front intermediate pipe.

14. Install the supplied 3 1/2" clamp onto the outlet of the front intermediate pipe. Place the trimmed catalytic converter onto the previously installed front intermediate pipe. Be sure the notch and catalytic converter pin are properly aligned. Snug the clamp onto the catalytic converter inlet, but do not tighten at this time.

15. Place a supplied 3 1/2" clamp onto the front of the supplied rear intermediate pipe.

16. Install the supplied rear intermediate pipe onto the catalytic converter outlet. Lightly snug the 3 1/2" clamp onto the front of the intermediate pipe / catalytic converter outlet.

Figure 2

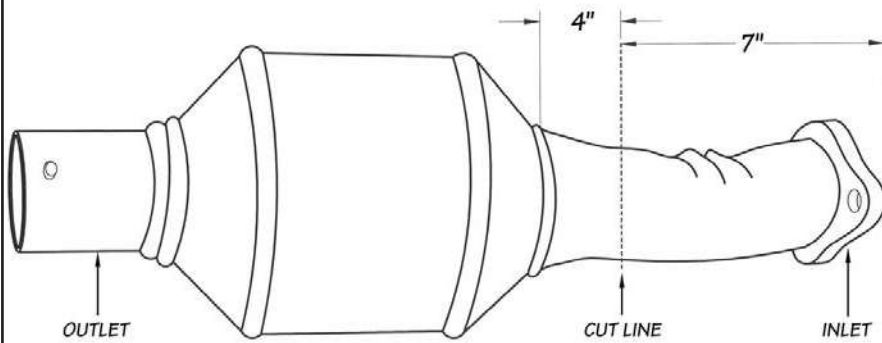

19. Remove the two (2) factory nuts that mount the front muffler hanger pin to the frame rail and remove the hanger pin from the vehicle.

Note: Extended cab short bed models will NOT use the two (2) 3/8" spacers.

20. Re-install the frame mounted hanger pin using the two (2) 3/8" long steel spacers onto the factory exhaust hanger studs. Install the hanger/spacer assembly into the vehicle frame holes about 10-16" to the rear of the original muffler hanger location (see **Figure 3**).

Note: spacers are to be installed between the hanger pin and the inside of the frame rail. Torque factory nuts to 20 ft-lbs.

21. Using a pry bar, completely remove the rubber hanger from the front muffler hanger pin.

22. Reinstall the rubber hanger onto the mounted hanger pin assembly.

23. Install the single pin front hanger clamp onto the rear of the intermediate pipe with the hanger pin on the inside facing the muffler. Insert the hanger pin into the vehicle's rubber grommet. Install the inlet of the Banks Monster muffler to the intermediate pipe.

24. Install the dual pin rear hanger clamp onto the outlet of the Monster muffler with the hanger pins on the inside, facing the muffler.

25. Route the tailpipe over the rear axle housing and into the muffler outlet. Install the tailpipe hanger pin into the corresponding rubber hanger. Loosely snug the 4" hanger clamp onto the muffler outlet.

26. Install the 5" Monster tailpipe tip on the exhaust. Keep the wrapping on until installation is complete. The tip should be rotated so the clamp nut and drain hole are pointing down. Align the end of the tip with the bodyline of the truck.

Proceed to **Step 37**.

Figure 3

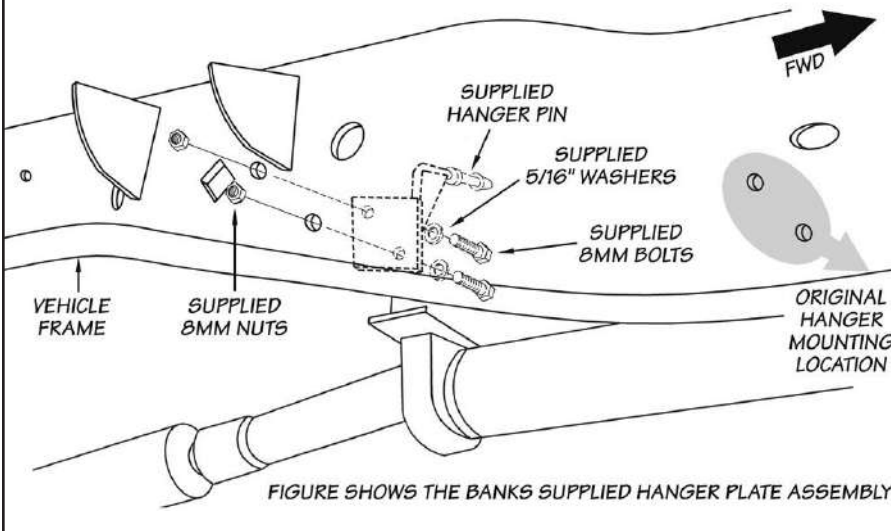

Note: Exhaust clamps should be placed at the beginning of the slot and evenly tightened.

Step 17 thru 26 applies only to single tailpipe systems.

Skip to **Step 27 thru 36** if installing Banks-Dual Monster Exhaust System.

Single Tailpipe System (**Step 17 thru 27**)

17. Crew-cab long-bed model only, Install the supplied extension pipe onto the intermediate pipe and snug a supplied 4" clamp onto the connection.

18. Relocate the factory-installed frame-mounted hanger pin that is located behind the rear transmission cross member.

Banks Split-Dual Monster Exhaust System (Step 27 thru 36)

27. For Long Bed models, install the supplied hanger clamp onto the intermediate pipe outlet. Insert the hanger clamp pin into the vehicle's rubber grommet (see **Figure 4**).

28. For Short Bed models, install a 4" clamp on the inlet of the Banks Monster muffler.

29. Install the Banks Monster Muffler onto the intermediate pipe outlet and lightly tighten the 4" clamp / hanger clamp. Note inlet labeling stamped on the bottom of the muffler. Orient the Banks Monster emboss such that it is level with the frame.

30. For Short Bed models, install the supplied hanger clamp onto the Monster Muffler outlet. Insert the hanger clamp pin into the vehicle's rubber grommet (see **Figure 4**).

31. For Long Bed models, install a 4" clamp on the outlet of the Banks Monster muffler.

32. Install the Y-pipe into the Monster Muffler outlet. Insert the two y-pipe hanger pins into the vehicles rubber grommets (see **Figure 4**).

33. Install the Banks rubber insulator onto the supplied hanger bracket. Locate the two slots on the rear driver side frame and install the hanger bracket assembly using the 7/16" Hardware (see **Figure 5**).

34. Install two 3 1/2" clamps onto the top and bottom of the Y-pipe. Route the Driver side tailpipe over the axle and insert into the upper Y-pipe. Install the tailpipe hanger pin into the rubber grommet.

35. Route the Passenger side tailpipe over the axle and insert into the lower Y-pipe. Install the tailpipe hanger pin into the Banks rubber grommet.

36. Move the spare tire to the rear of the vehicle. Adjust the tailpipe tips to be 1/2" off the body panel and snug the two 3 1/2" clamps. Move the spare tire such that there is equal distance for each tailpipe (see **Figure 6**).

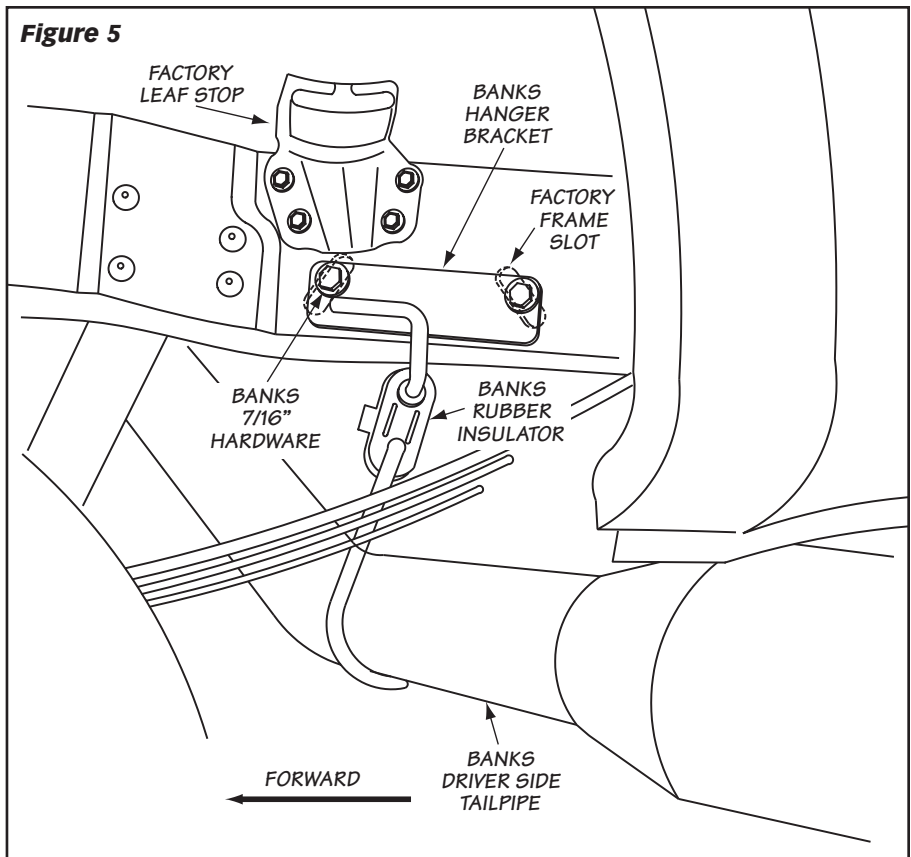
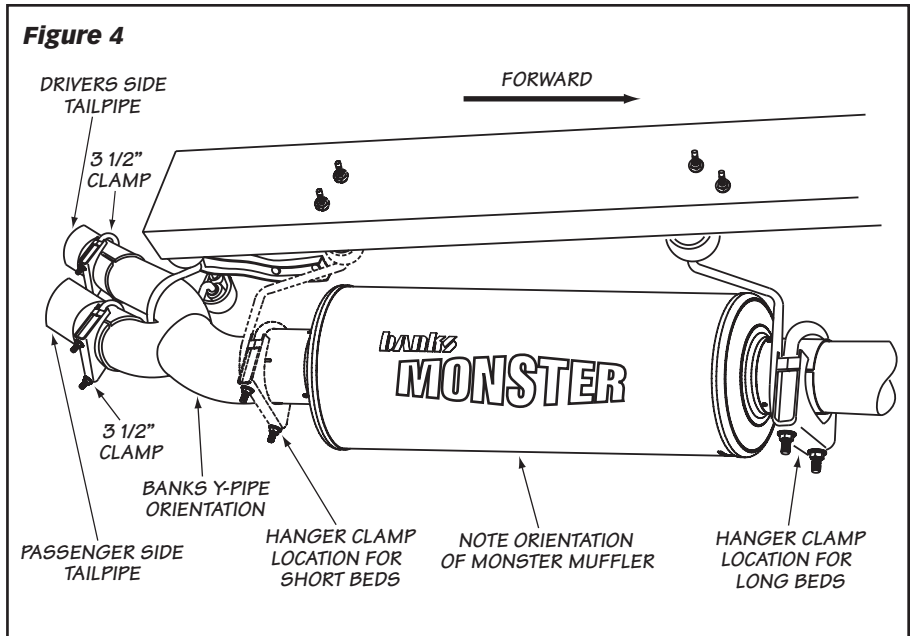
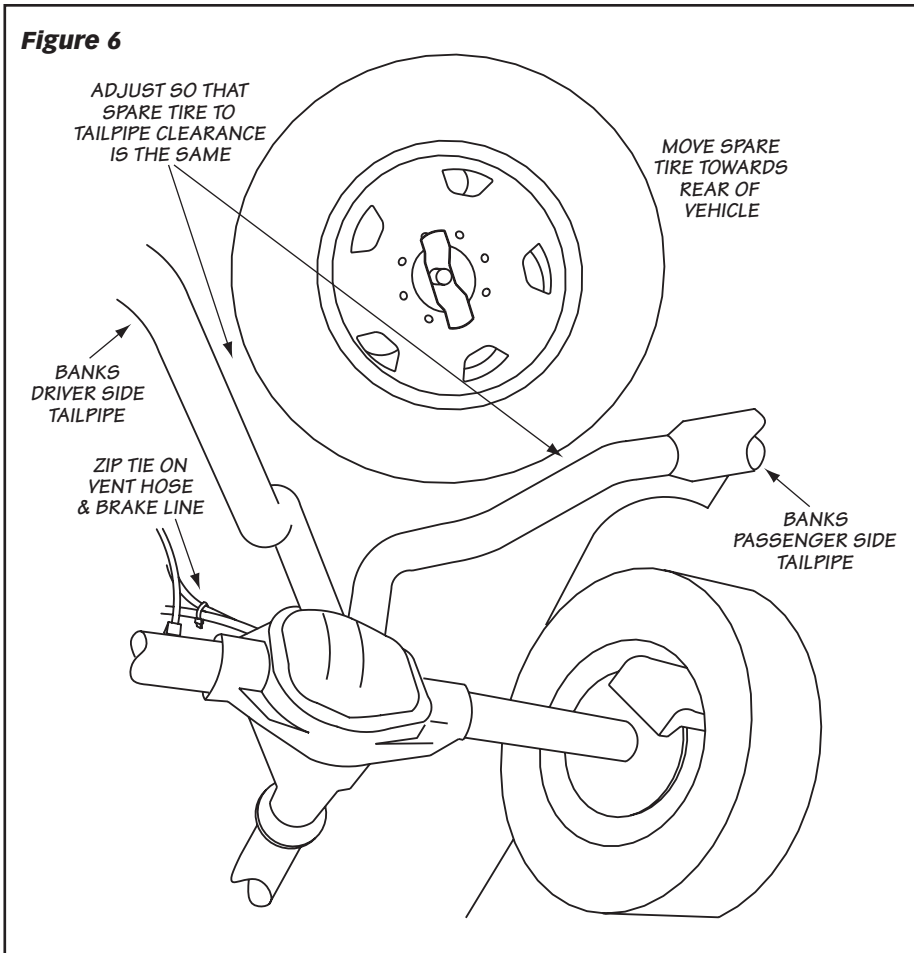

Figure 6



ALL MODELS

37. With everything positioned properly, begin to tighten the clamps starting with the ones closest to the front and working your way back. Torque the exhaust clamps evenly to 35 ft-lbs. Make sure that each slip is fully inserted (+/-1/4 inch) and that all mount hangers are in the forward position (see **Figure 7**). Torque 7/16" hanger bracket hardware to 45 ft-lbs.

38. Remove the protective covering from the tailpipe tip.

Caution: The protective covering may ignite and burn if not removed prior to running the engine.

39. Tighten the exhaust clamps as necessary. Whenever possible, tack-welding slip connections to prevent disengagement is recommended. The Banks Monster Exhaust installation is now complete.

-END, SECTION 1-

Figure 7

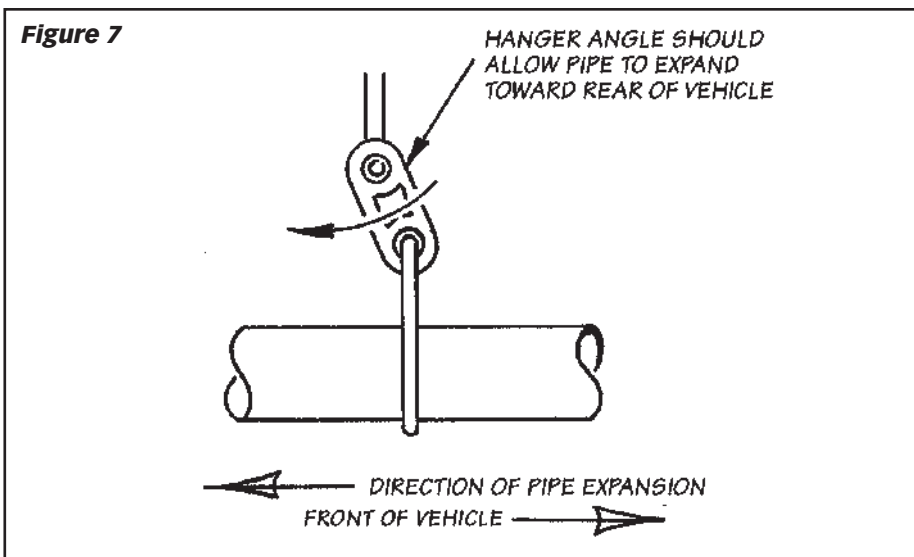

Section 2

TECHNI-COOLER ASSEMBLY INSTALLATION

Figure 8
 General Assembly
 Banks Techni-Cooler Intercooler System

Item	Description	P/N	Qty
1	Techni-Cooler Assembly	25536	1
2	Boost Tube, Left	41324	1
3	Boost Tube, Right	41325	1
4	Hose, 3.5" x 3.25", Black	94215	1
5	Hose, 2.5" x 2.5", 5-ply, Black	94273	1
6	Hump Hose, 3.5" x 3.25", Black	94293	2
7	High-Ram Intake Manifold		
	2003-04	42745	1
	2005-07	42746	1
8	Gasket, High-Ram Intake	93038	1
9	Stud, High-Ram Air Intake M6-1.0 x 1/4-20 x 4.365 (03-04)	91534	3
9	Stud, High-Ram Air Intake M6-1.0 x 1/4-20 x 6.185 (05-07)	91536	2
10	Stud, High-Ram Air Intake M6-1.0 x 1/4-20 x 6.725 (03-04)	91535	1
10	Stud, High-Ram Air Intake M6-1.0 x 1/4-20 x 6.595 (05-07)	91537	2
11	Nut, Nylock 1/4"-20	91110	4
12	Washer, SAE Flat, Zinc 1/4"	91102	4
13	Washer, Thread Sealing 1/4"-20	91106	2
14	O-Ring, High-Ram	93606	2
15	Spacer, Battery Box	91890	1
16	Hex-Bolt, Washer Head, Black 8mm-1.25 x 30mm	91810	2
17	Hose clamp, 3.5" Spring Loaded	92897	6
18	Hose clamp, 2.5" Spring Loaded	—	*

* These are stock components that will be re-used with the Banks Techni-Cooler System

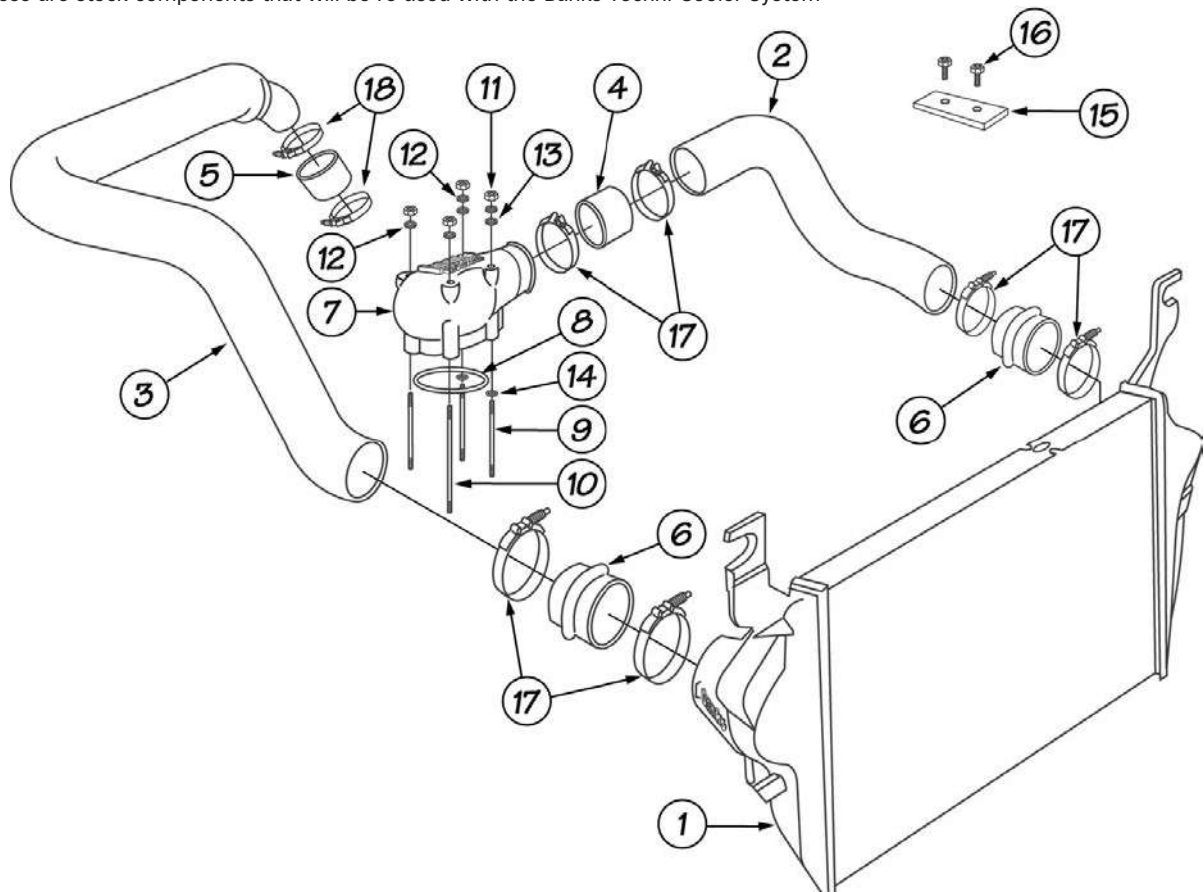
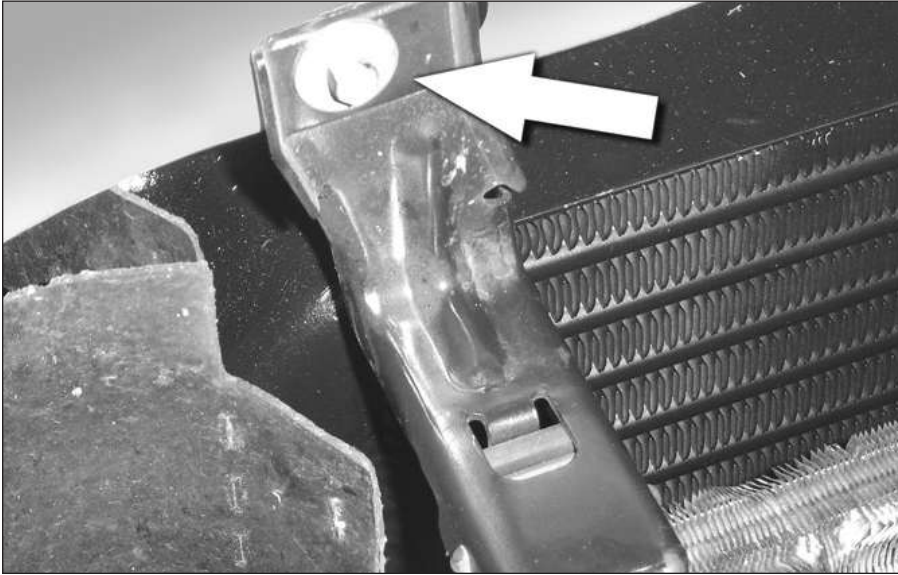

Figure 9



Note: If installing a Stinger System, proceed to Section 3.

REMOVE STOCK COMPONENTS

Note: Save all factory components and fasteners that are removed for re-installation with the exception of: Charge Air Cooler (CAC), Intake Elbow, Boost Tubes, and CAC Hose Connections.

1. Remove all of the plastic pushpins that attach the upper radiator air deflector to the grill support and upper radiator support.

2. Remove the upper radiator air deflector.

3. Place reference marks around the hood latch to mark its location. These marks will be used to orient the hood latch upon re-installation.

4. Unbolt and remove the hood latch from the support. Do not disconnect the cable; just place the hood latch assembly out of the way.

5. Remove the two upper a/c condenser mounting brackets that are attached to the upper radiator support as shown in **Figure 9**.

6. Remove the 2 bolts that attach the upper Charge Air Cooler (CAC) mounts to the upper radiator support as shown in **Figure 10**.

7. Remove the two radiator support brackets as shown in **Figure 11**.

8. Remove the driver and passenger side pushpins that attach the air deflectors to the radiator support as shown in **Figure 12**.

9. Un-clip the battery cable that is attached to the radiator support.

10. Remove the 8 bolts that attach the upper radiator support to the core support.

11. Remove the radiator support. It may be necessary to pry it out of the slots in the core support.

12. Undo the two toggle clamps at the rear of the air box assembly.

13. Disengage the two tabs on the lower backside of the air box assembly from the slots on the rear cover.

14. Remove the air box assembly and air box front cover from the vehicle.

Figure 10

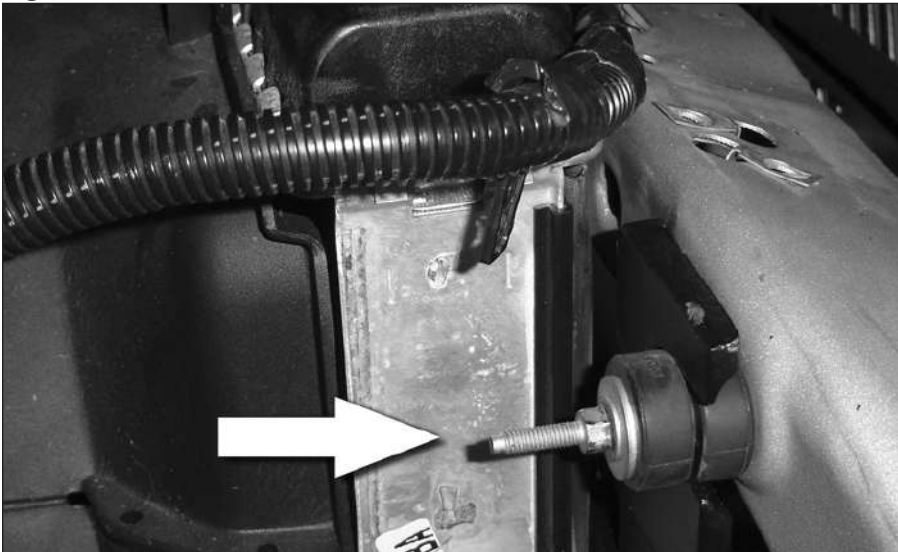
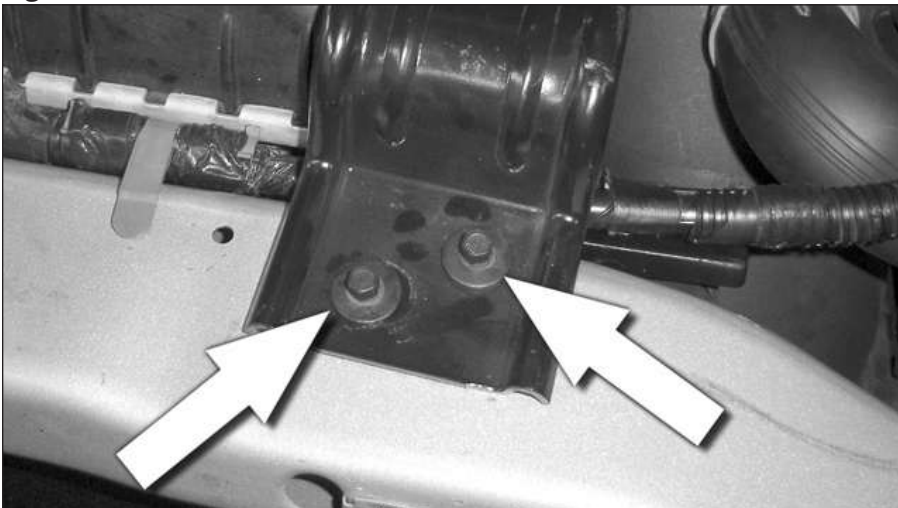

Figure 11



15. For 2005-07 4-wheel drive equipped vehicles only: Remove the electronics module near the driver side battery shown in **Figure 13**. The retaining tab for the module can be pried back with a flat blade screwdriver as shown in the **Figure 13**.

After the tab is depressed, the module can easily be pulled away from its mounting bracket.

Note: Be careful not to break the plastic box, as it will be re-installed later

16. Remove the wire harness plastic retaining clip on the back of the plastic battery box.

17. Remove the plastic battery box [(4x) 13mm socket].

For 2005-07 4-wheel drive equipped vehicles only: A small bracket used to mount an electronic module will also be removed with the plastic battery tray.

18. Remove both the driver and passenger side boost tubes and their attachment hoses. The passenger side boost tube is the 3-inch diameter tube that connects the compressor discharge to the charge air cooler. The driver's side boost tube connects the charge air cooler to the intake manifold. Retain the hose clamps that attach the passenger side boost tubes to the turbocharger, as these components will be re-used.

19. Remove the four Allen head bolts that attach the stock intake elbow. The intake elbow is the 90-degree transition from the driver side boost tube to the intake manifold.

Figure 12

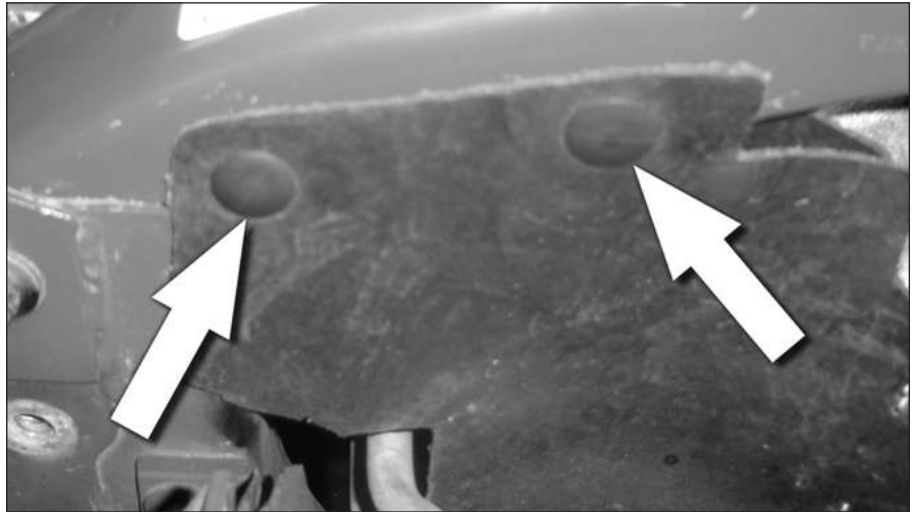

Figure 13

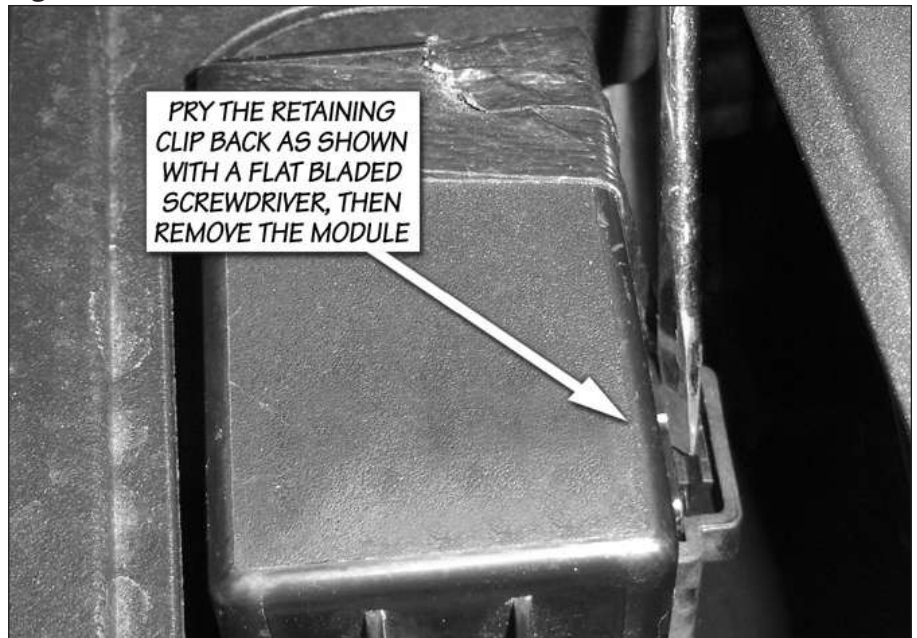

Figure 14

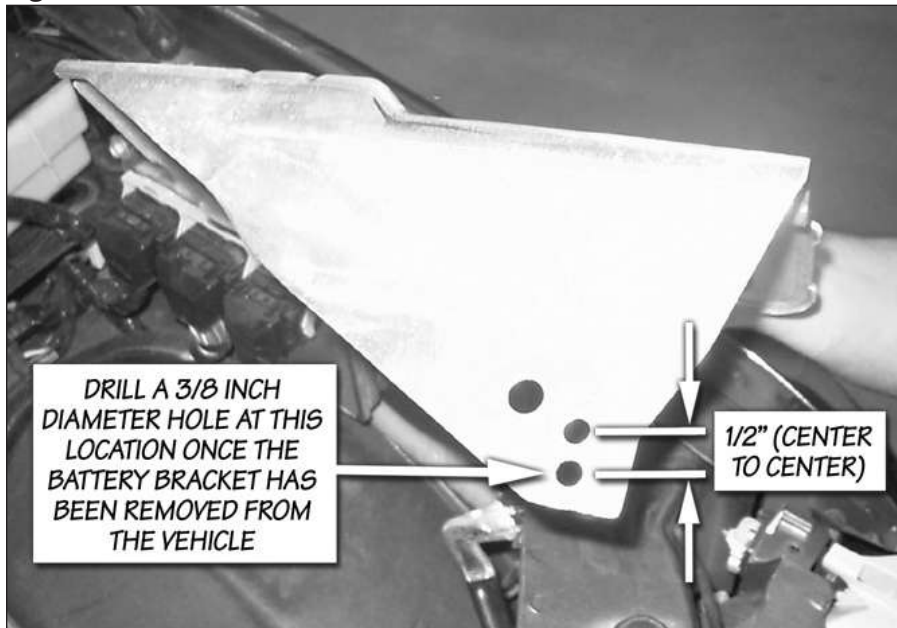
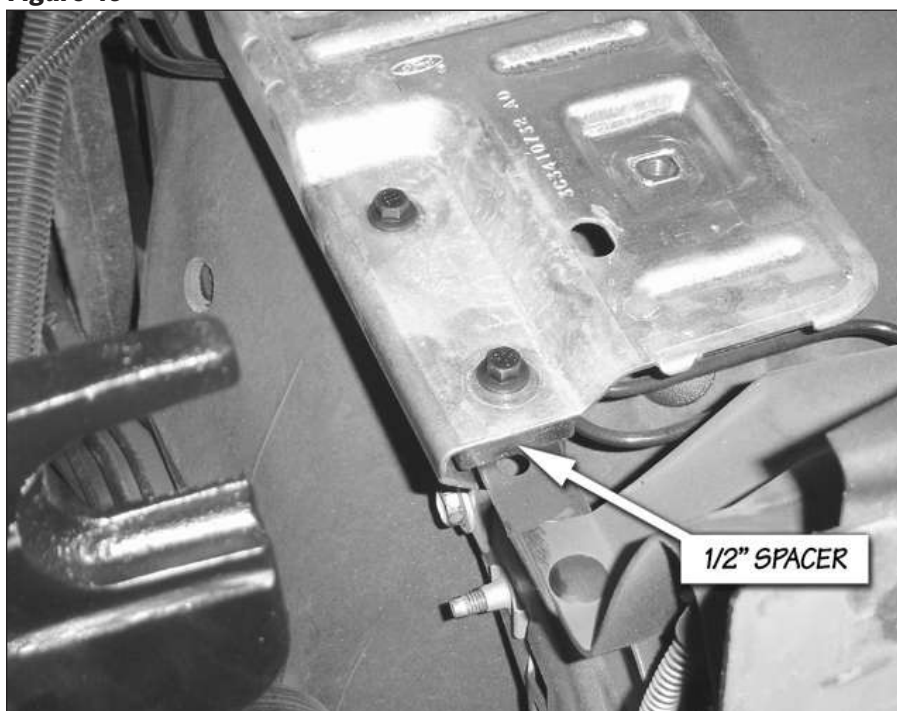

Figure 15



20. Remove the stock intake elbow and gasket.

21. Cover the compressor outlet on the turbocharger and the inlet to the intake manifold to prevent debris from getting into either of these areas.

22. Remove the stock CAC.

MODIFICATIONS TO MAKE ROOM FOR THE BANKS TECHNI-COOLER SYSTEM

23. For 2005-07 4-wheel drive equipped vehicles only: Remove the two retaining clips that attach the wire harness to the metal battery tray.

24. Remove the driver's side metal battery tray [(3x) 13mm socket].

25. Drill a 3/8 inch hole as shown in **Figure 14**.

26. Reinstall the battery tray as shown in **Figure 15** with the supplied 1/2" spacer and longer supplied 8mm bolts. Torque the bolts to 12 ft-lbs.

TRIM BRACKETS

2003 to 2004 vehicles only (Steps 27 through 33)

If installing on 2005-2007 vehicle proceed to Step 34.

27. Remove the passenger side battery hold down clamp [(1x) 8mm socket].

28. Remove the passenger side battery.

WARNING: When lifting a battery, excessive pressure on the end walls could cause acid to spew through the vent caps, resulting in personal injury. Lift with a battery carrier or with hands on opposite corners. Failure to follow these instructions may result in personal injury.

29. Remove the plastic clip that attaches the (+) battery cable to the rear of the passenger side battery tray

30. Remove the 4 bolts that secure the passenger side battery tray [(4x) 13mm socket].

31. Remove the passenger side battery tray.

32. Trim the bracket below the battery tray as shown in **Figure 16**.

Note: Be careful not to cut the a/c lines that are in close proximity to the bracket.

33. Re-install the passenger side battery tray and battery. Tighten the battery tray bolts to 12 ft-lbs and the battery hold down clamp to 89 in-lbs. Re-attach the harness mounting clip at the rear of the tray, but leave the cables disconnected from the battery until the installation is complete.

ALL VEHICLES

34. Trim the fan shroud as shown in **Figure 17** using **Template 1** in **Page 39** of this manual, to clear the larger diameter boost tubes.

35. Trim the fan shroud as shown in **Figure 18** using **Template 2** in **Page 39** of this manual, to clear the Banks High Ram.

Note: 2005-07 vehicles require a different trim to fan shroud, use appropriate template. See **Template 2**.

Figure 16



Figure 17



Figure 18



BANKS TECHNI-COOLER INSTALLATION

36. For 2003 vehicles only: Remove the rubber air deflectors from the face of the stock CAC. Install the rubber air deflectors removed from the stock CAC on the Banks CAC. Use the supplied zip tie mounts to affix the air deflectors to the Banks CAC. Discard the supplied zip tie mounts for vehicles that are not equipped with the rubber air deflectors.

37. Remove the rubber saddle mounts and grommets used to mount the stock CAC and install them on the Banks CAC.

38. Install the Banks CAC into the factory lower saddle mounts.

39. Reinstall the upper radiator support. Leave the 8 bolts that retain the support hand tight. This will allow

the position of the upper core support to be aligned with the Banks CAC.

40. Install the bolt at each of the upper CAC mounts and torque to 19 ft-lbs.

41. Torque the eight upper radiator support bolts to 22 ft-lbs.

42. Reinstall the radiator support brackets and torque to 22 ft-lbs.

43. Re-affix the two upper air conditioning condenser mounts and torque to 80 in-lbs.

44. Re-attach the hood latch in the outline that was previously marked. Torque the hood latch bolts to 9 ft-lb.

45. Re-attach the pushpins that attach the driver and passenger side air deflectors to the radiator support.

46. Re-install the upper radiator air deflector with pushpins.

HIGH-RAM INSTALLATION

47. Apply the supplied thread locker to the M6 threaded side of the High Ram studs. The M6 thread length is shorter than the 1/4"-20 threads on the opposite ends of the studs.

48. Using the two 1/4"-20 nuts provided, tighten the High Ram studs into the intake manifold by threading both nuts onto the stud. Tighten the nuts against each other using two open-end wrenches, then tighten the stud by turning the wrench on the top nut. The stud should be torqued to 2 ft-lbs. Reverse the process to remove the nut and repeat for each stud.

49. 2003 to 2004 vehicles only: Remove 0.75" of the split loom near the connector shown in **Figure 19** to provide additional clearance for the High-Ram.

50. Install the supplied o-rings on the two driver side studs as shown in the exploded view in **Figure 20**. Slide the o-rings down to the base of the intake manifold.

51. For 2003 to 2004 vehicles, install the factory replacement intake manifold gasket in the groove on the intake manifold. *For 2005-06 vehicles,* install the factory replacement intake manifold gasket on the High Ram.

52. Slide the High-Ram over the installed studs.

53. Place the thread sealing washers on the two driver side studs. Use a twisting motion to thread the sealing washers over the threaded portion of the studs to avoid tearing the seals. Install standard flat washers on the passenger side studs and on top of the thread sealing washers, as shown in **Figure 20**.

Figure 19

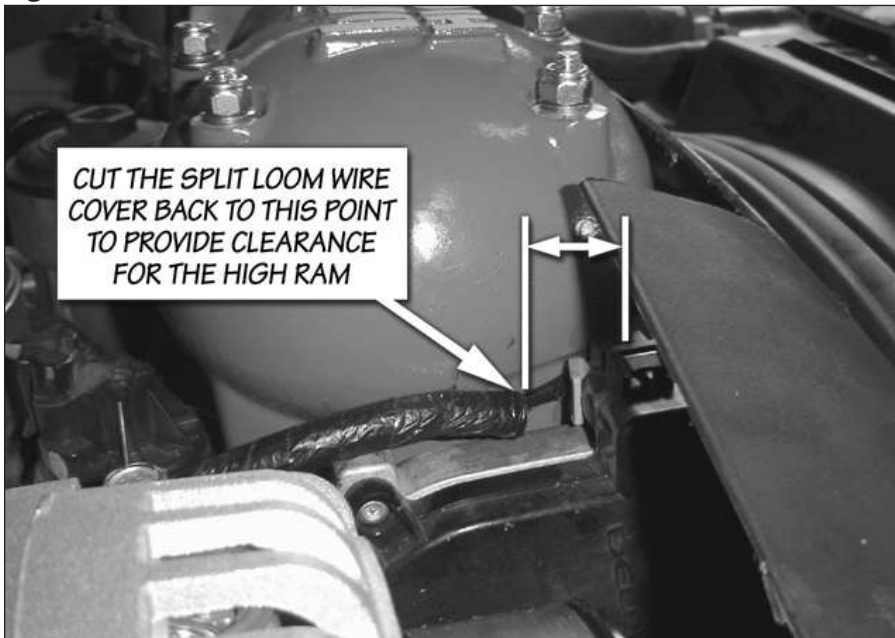

54. Secure the High Ram with (4x) 1/4"-20 Nylon locking nuts. Torque to 9 ft-lbs.

NOTE: Before slipping any boost tubes and the corresponding hoses, into position, ensure that all connection ends are clean and free of any oil residue and contaminants.

Clean compressor outlet and all connection points with a non-oil based solvent such as Acetone, Mineral Spirits, Denatured Alcohol or Lacquer Thinner. Read and follow the manufactures operation instruction for non-oil based solvent cleaner.

55. Install the driver and passenger side boost tubes and connection hoses as shown in **Figure 8** The connection hoses should be slid firmly against the hose stops provided on the CAC and High Ram. Allow a minimum 1/8" air gap between CAC, High Ram and boost tubes. *Note: The a/c line on the passenger side may need to be bent to provide clearance for the boost tube. On 2003 to 2004 vehicles: The brake line on the driver side may need to be slightly bent to provide additional clearance for the boost tube. On 2005-07 vehicles: One of the power steering fluid lines may need to be bent to provide clearance for the driver side boost tube.*

56. The hose clamps on the High Ram must be positioned as shown in **Figure 21** to avoid contact with the hood.

57. Tighten the hose clamps to 75 inch-lbs (not ft-lbs!).

58. Re-install the air filter assembly box and air box front cover.

-END, SECTION 2-

Figure 20

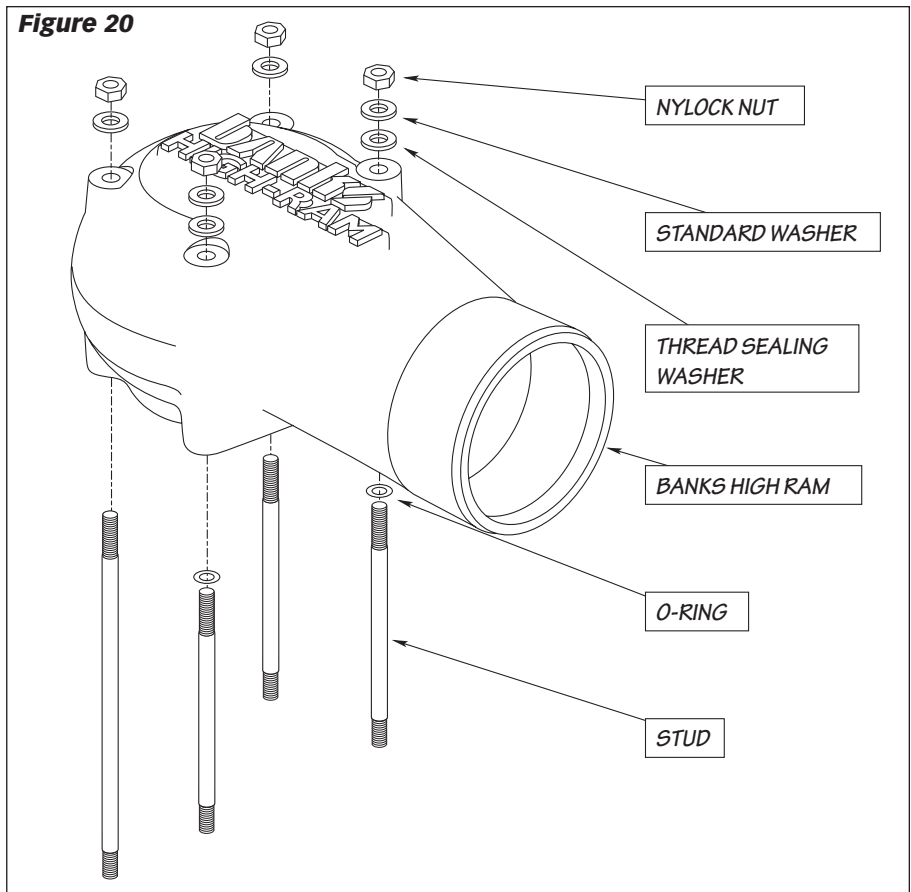

Fig 21



Section 3

THERMOCOUPLE INSTALLATION

Figure 22

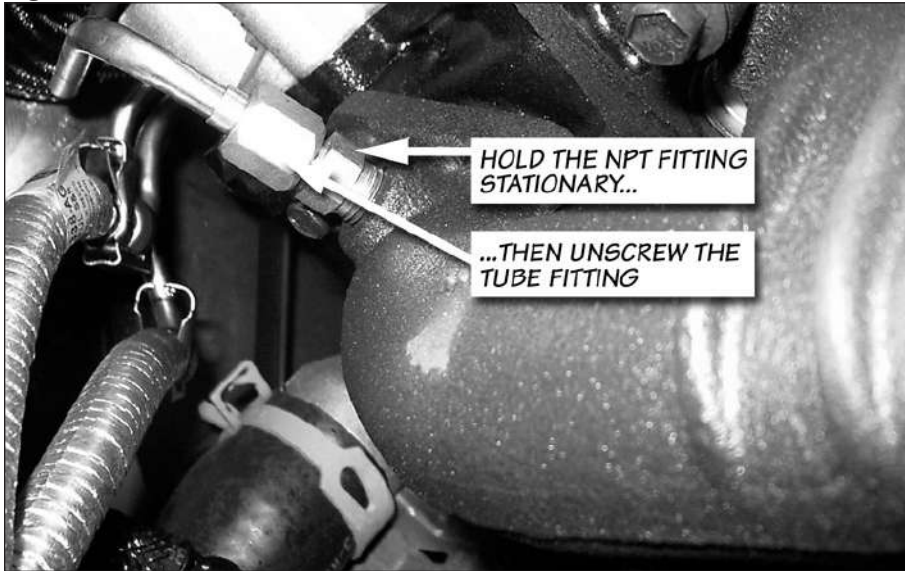
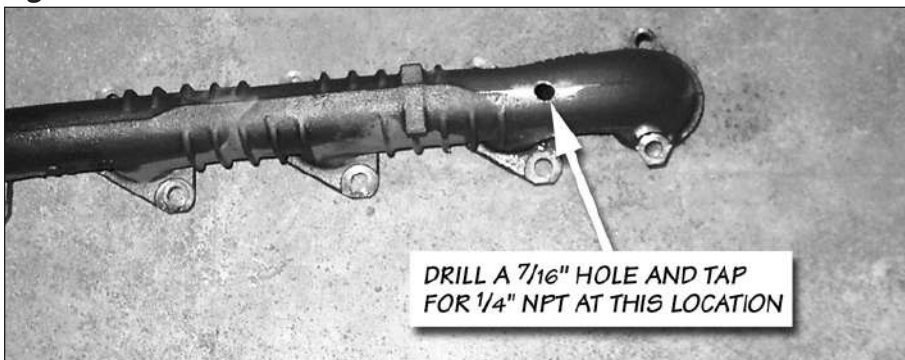

Figure 23



1. The thermocouple monitors the temperature of the exhaust gases entering the turbocharger at the turbine housing. Installation requires that the exhaust manifold be drilled near the manifold outlet. The manifold must be removed from the engine to thoroughly clean out all metal chips from drilling. All metal shavings must be cleaned from the manifold to avoid turbine wheel damage and possible interference with the turbochargers variable geometry turbine stage.

2. Disconnect the Exhaust Back Pressure Sensor tap located at the front of the driver side manifold. The pressure tap must be removed by using a 9/16" open-end wrench to hold the fitting stationary, and loosen the tube using a 5/8" open-end wrench. The fitting is shown in **Figure 22**.

Note: Failure to hold the fitting stationary will damage the tube upon removal.

3. Remove the driver side exhaust manifold.
4. Drill a 7/16" hole in the driver side exhaust manifold at the location shown in **Figure 23**.
5. Tap the hole for a 1/4" NPT thread. Check the thread depth as you tap by periodically removing the tap and screwing the pipe coupling into the tapped hole. The coupling should thread in 3 to 3 1/2 turns hand tight. Do not install the probe in place at this time. **Caution: Running the tap too deeply can prevent the pipe fitting from properly sealing.**

6. Remove the NPT fitting from the pyrometer and install it on the exhaust manifold. Use anti-seize lubricant on the threads and torque to 14-16 lb-ft.

7. Remove all metal chips from the exhaust manifold.

Note: Failure to remove all metal chips could result in catastrophic damage to the turbocharger's turbine wheel or interfere with the operation of the variable geometry vane mechanism.

8. Re-install the exhaust manifold. Apply anti-seize lubricant to the manifold bolt threads and torque to 28 lb-ft. Use the tightening sequence shown in **Figure 24**.

9. Tighten the turbocharger adapter pipe fasteners to 20 lb-ft as shown in **Figure 25**.

10. Reconnect the exhaust backpressure static line tube.

11. Install the DynaFact pyrometer probe in the fitting.

*Note: The thermocouple will be connected to the EconoMind in **Section 4, Step 11**.*

-END, SECTION 3-

Figure 24: Exhaust manifold tightening sequence

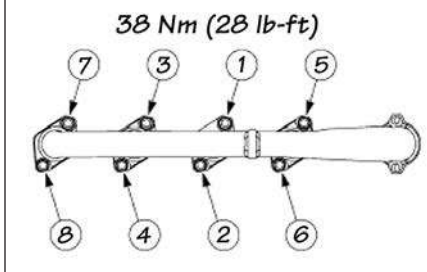
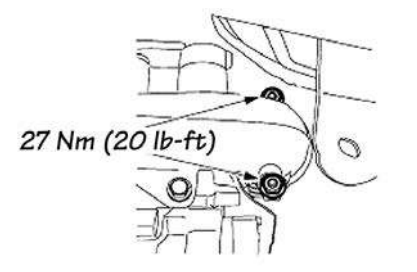

Figure 25: Turbocharger adapter pipe torque specification



Section 4

BANKS ECONOMIND DIESEL TUNER INSTALLATION

Banks EconoMind Diesel Tuner Installation

1. Make sure the previously removed driver side battery is not installed. If the driver side battery is installed or if any battery is still connected then refer to **Section 1 Steps 1 thru 5** for battery removal instructions.

2. Place the EconoMind Diesel Tuner in close proximity as shown in **Figure 27** for 2003-04 and **Figure 28** for 2005-07. The 'In-Cab Cable' with the three small connectors will be routed into the cabin through the grommet on the firewall.

The MAP sensor harness with the two connectors will be routed along the firewall to its prospective location listed in the following steps.

*Note: (The EconoMind Diesel Tuner will be affixed to its permanent location in **step 19.**)*

3. Locate the Powertrain Control Module (PCM) on the driver side of the vehicle engine compartment (see **Figure 29**).

4. Disconnect the middle connector from the PCM by opening the over center retaining clamp as shown in **Figure 29**. Route the disconnected PCM connector to the EconoMind Diesel Tuner as directed below:

2003-04 model year vehicles: Route the previously disconnected middle connector under the power steering fluid reservoir towards the EconoMind Diesel Tuner.

2005-07 model year vehicles: Route the previously disconnected middle connector in the most direct path towards the EconoMind Diesel Tuner.

5. All Years: Plug the PCM connector into the connector on the EconoMind Diesel Tuner labeled, "VEHICLE HARNESS".

6. Locate the supplied 'Crossover Cable' wiring harness in your EconoMind tuner kit.

7. Plug the supplied 'Crossover Cable' wiring harness into the EconoMind Diesel Tuner connector labeled, "BANKS HARNESS."

For 2005-07 Model years, slide EconoMind shield onto crossover cable.

*Note: Be sure that the seam on the top of the shield is facing away from the cabin (see **figure 32**).*

For all models, route the other end of the 'Crossover Cable' to the vehicle's PCM middle connector labeled "C". Route the 'Crossover Cable' as directed below:

2003-04 model year vehicles: Route the 'Crossover Cable' under the power steering fluid reservoir.

2005-07 model year vehicles: Route the 'Crossover Cable' to the PCM in the most direct path possible.

8. All Years: Plug the 'Crossover Cable' into the vehicle's PCM middle connector labeled "C".

9. Unplug the Manifold Absolute Pressure (MAP) sensor connector shown in **Figure 30**. The MAP connector can be unplugged by sliding the red safety slide down, pressing the locking button, then pulling on the connector.

Figure 26: EconoMind and supplied wiring harnesses

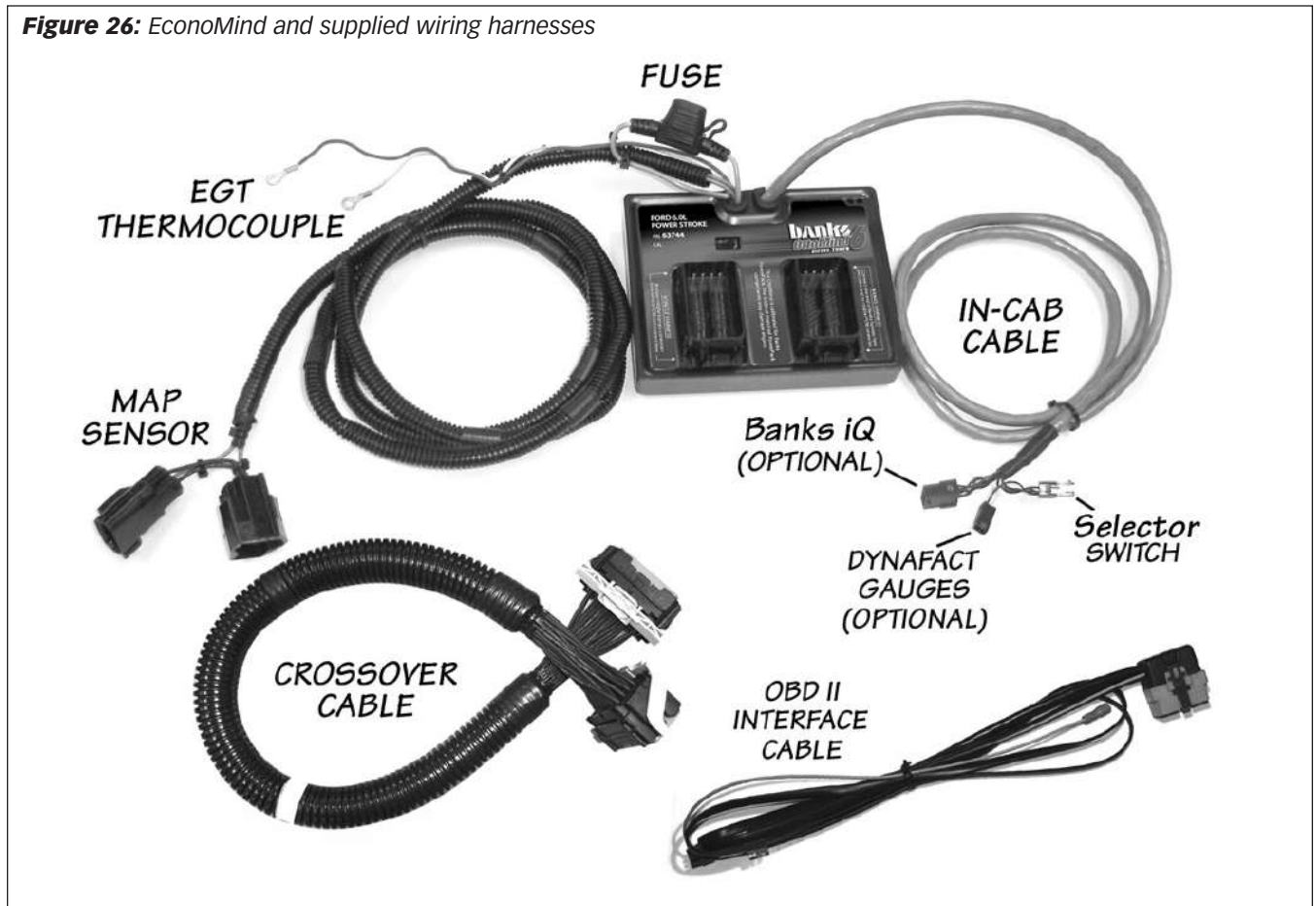

Figure 27

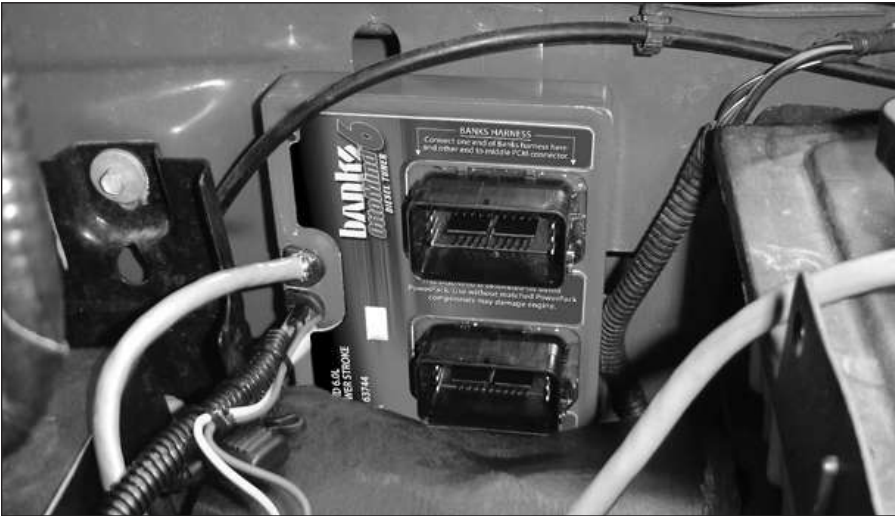

Figure 28

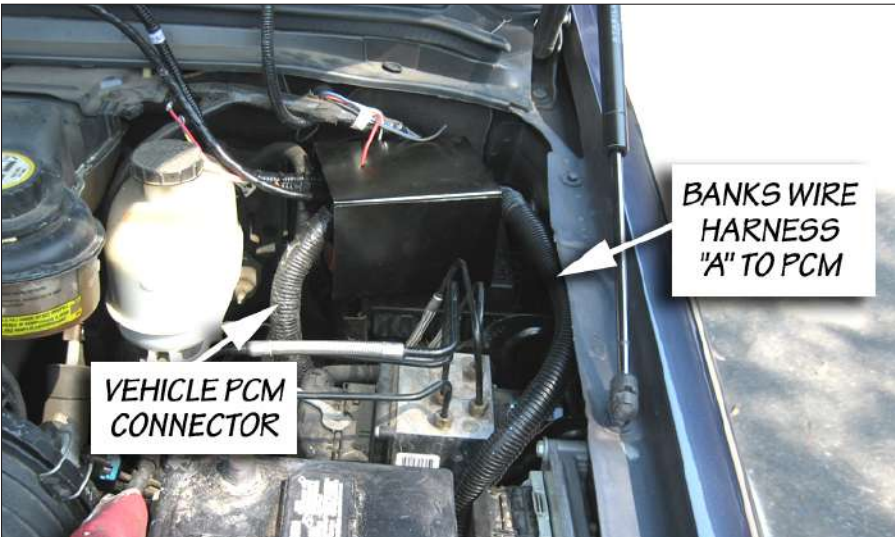
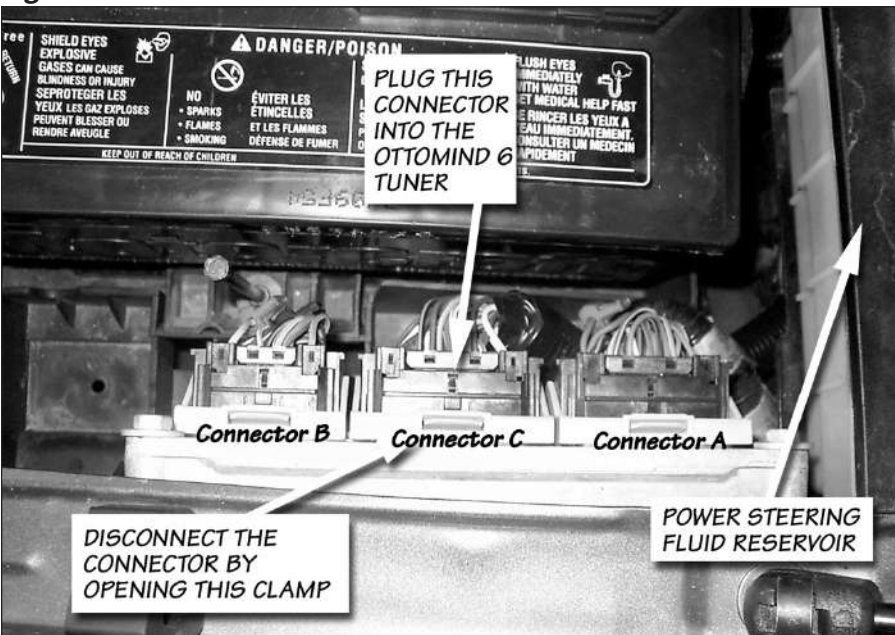

Figure 29



10. Plug the EconoMind MAP connector into the MAP sensor. Plug the factory MAP connector into the EconoMind MAP wiring harness. Route the harness from the EconoMind to the MAP sensor as shown in **Figure 31**. Use the supplied zip ties to secure the MAP harness to the factory harness. Failure to follow the recommended harness routing may result in a melted harness.

11. Connect the sensor wire to the EconoMind tuner with the supplied screws. The YELLOW sensor wire attaches to the free YELLOW wire on the EconoMind tuner. The red sensor wire attaches to the free red wire on the EconoMind tuner.

12. Slide the heat shrink over the exposed metal junction, and apply moderate heat to seal the connection. A heat gun works well.

13. Route the EconoMind 'In-Cab Cable' through the firewall to the passenger compartment. When passing through the firewall, either make a hole in a factory grommet or drill a hole and use a new grommet. If drilling, check the backside to make sure there are no components that may be damaged by drilling.

14. Remove the lower driver side interior panel that allows access to the fuse box.

15. From inside the vehicle, continue to pull the cable through the firewall until it is approximately 22" inside the cab. Secure the cable to the lower access panel area. Take precaution to leave the three connectors accessible for usage further in the installation process.

16. Locate the 'OBDII Interface Cable' in your kit. Connect the 'OBDII Interface Cable' to the vehicle OBDII connector. Use the large cable tie in your kit as shown in **Figure 33** to secure the 'OBDII Interface Cable' to the vehicle OBDII connector. Now, connect the 8-pin connector from the 'OBDII Interface Cable' to the 8-pin connector on the EconoMind 'In-Cab Cable'.

Note: If you are not installing the optional Banks iQ then coil up and secure cable with the RJ12 (telephone style) connector end.

17. Remove the fuse box cover, located in the cabin compartment. Locate the mini-fuse #22 and remove. Install the mini-auto blade fuse tap onto the removed mini fuse as shown in **Figure 34** Re-install the mini fuse with the attached blade tap into location #22 as shown in **Figure 35**.

18. Locate the RED single terminal connector on the 'OBDII Interface Cable' and connect it to the mini-fuse blade tap location #22. Replace the fuse cover and make sure not to pinch the RED single terminal wire.

Mounting The EconoMind Diesel Tuner

19. 2003-04 model year vehicles only: Remove the clip shown in **Figure 37** to create adequate room to mount the EconoMind Diesel Tuner to the driver side inner fender.

20. 2003-04 four-wheel drive vehicles: The module shown in **Figure 37** will appear only in four-wheel-drive vehicles. This may need to be relocated to make room for the EconoMind Diesel Tuner. The mounting location of this module by the factory has not been consistent on early vehicles.

NOTE: Make sure the entire mounting surface is clean and free of dirt and oil before mounting the EconoMind Diesel Tuner. Clean and dry as required using a cloth damped in rubbing alcohol or similar cleaning solution.

Figure 30

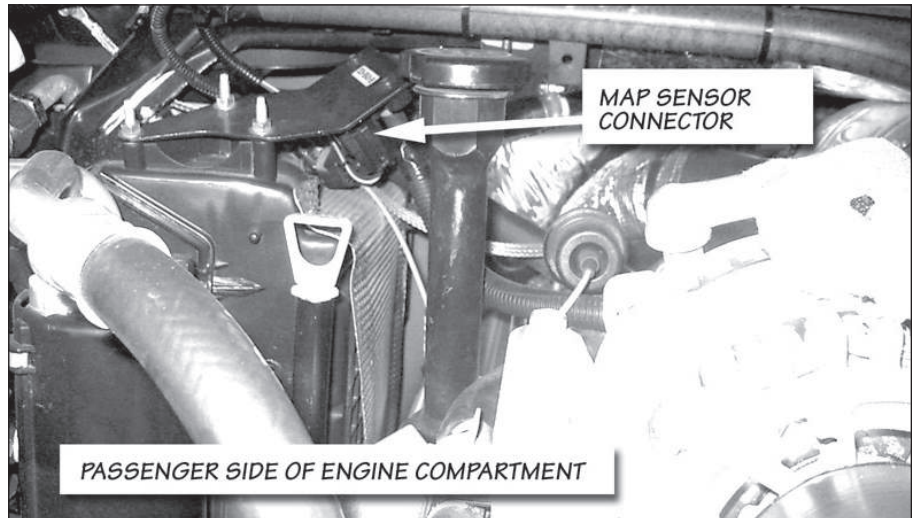

Figure 31

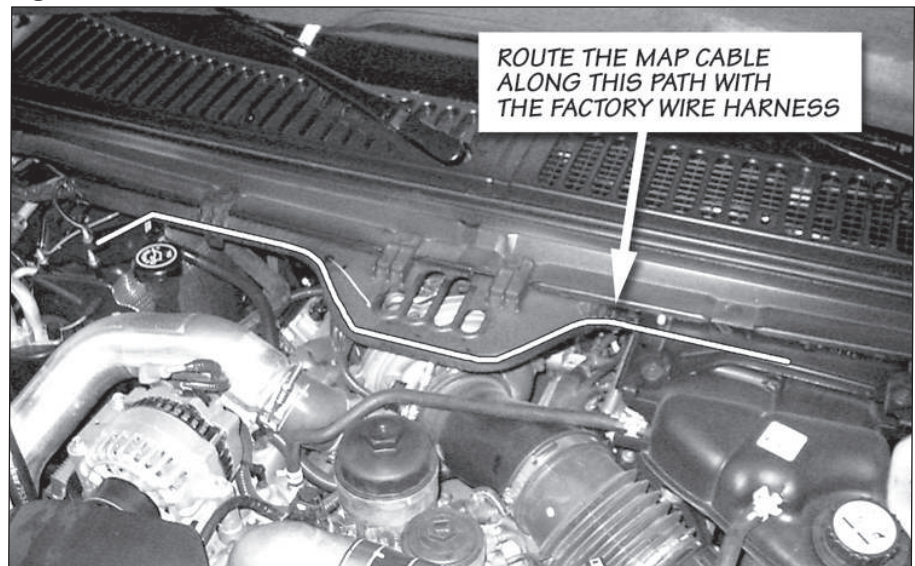

Figure 32

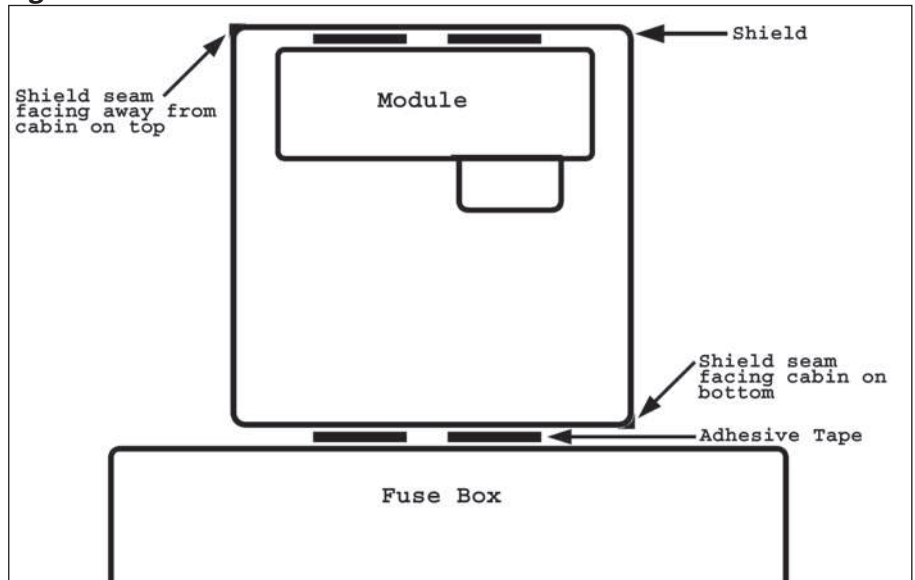

Figure 33



Figure 34

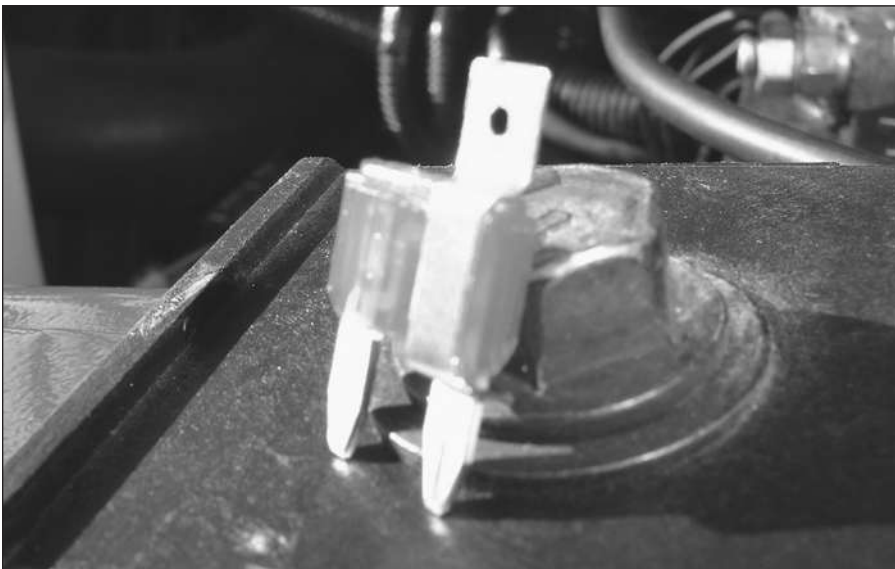

Figure 35



21. 2005-07 model year vehicles only: Remove the adhesive backing from two (2) dual-lock fasteners and attach them to the EconoMind shield and attach the other end to the top of the fuse box.

22. Remove the adhesive backing from the (2) dual-lock fasteners on the back of the EconoMind Diesel Tuner and affix the tuner to:

2003-04 model year vehicles: The inner driver side fender as shown in **Figure 27**.

Note: Shield will not be used for installations on 03-04 models. Shield will only be used on 05-07 models.

2005-07 model year vehicles: The inside roof of the EconoMind shield, that is mounted on the fuse box cover as shown in **Figure 28 & 32**.

23. Re-install the plastic driver side battery box. Torque the attachment bolts to 12 ft-lbs.

24. Re-install the driver's side battery, battery hold down clamp, and plastic battery cover. Torque the hold down clamp retaining bolt to 89 in-lbs.

WARNING: When lifting a battery, excessive pressure on the end walls could cause acid to spew through the vent caps, resulting in personal injury. Lift with a battery carrier or with hands on opposite corners. Failure to follow these instructions may result in personal injury.

25. For 2003-04 4-wheel drive equipped vehicles only: Re-install the electronic module near the driver side battery. The module is shown in **Figure 37**.

26. Re-install the driver and passenger (+) and (-) battery cables

-END, SECTION 4-

Figure 37

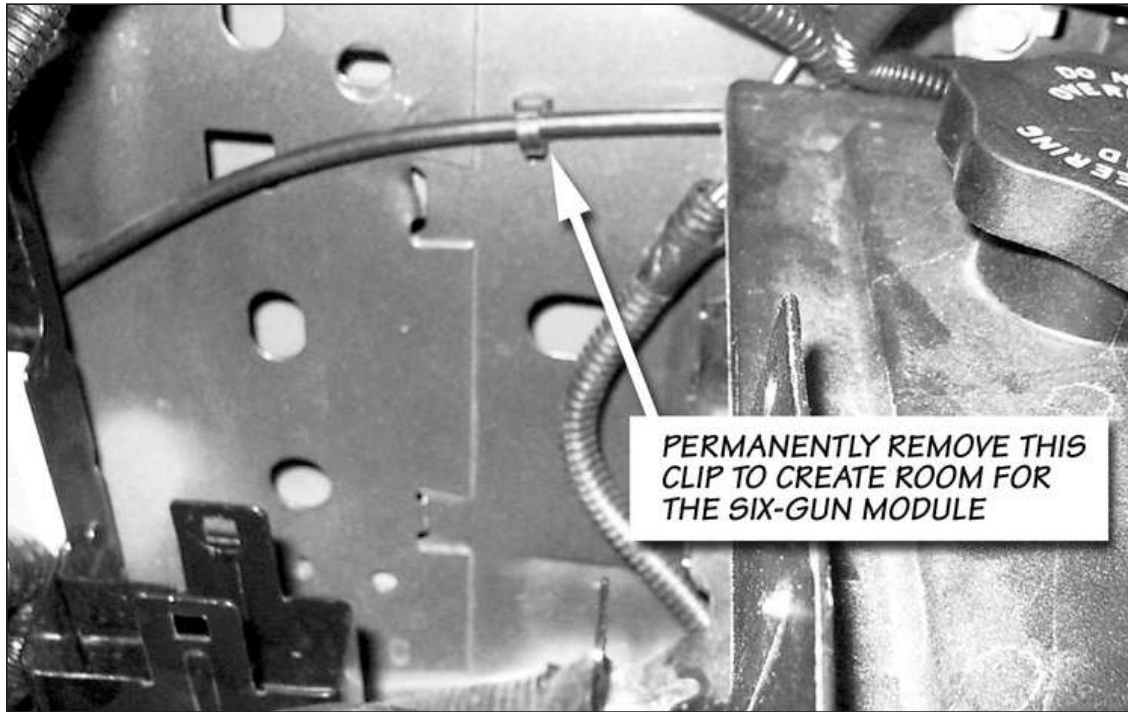
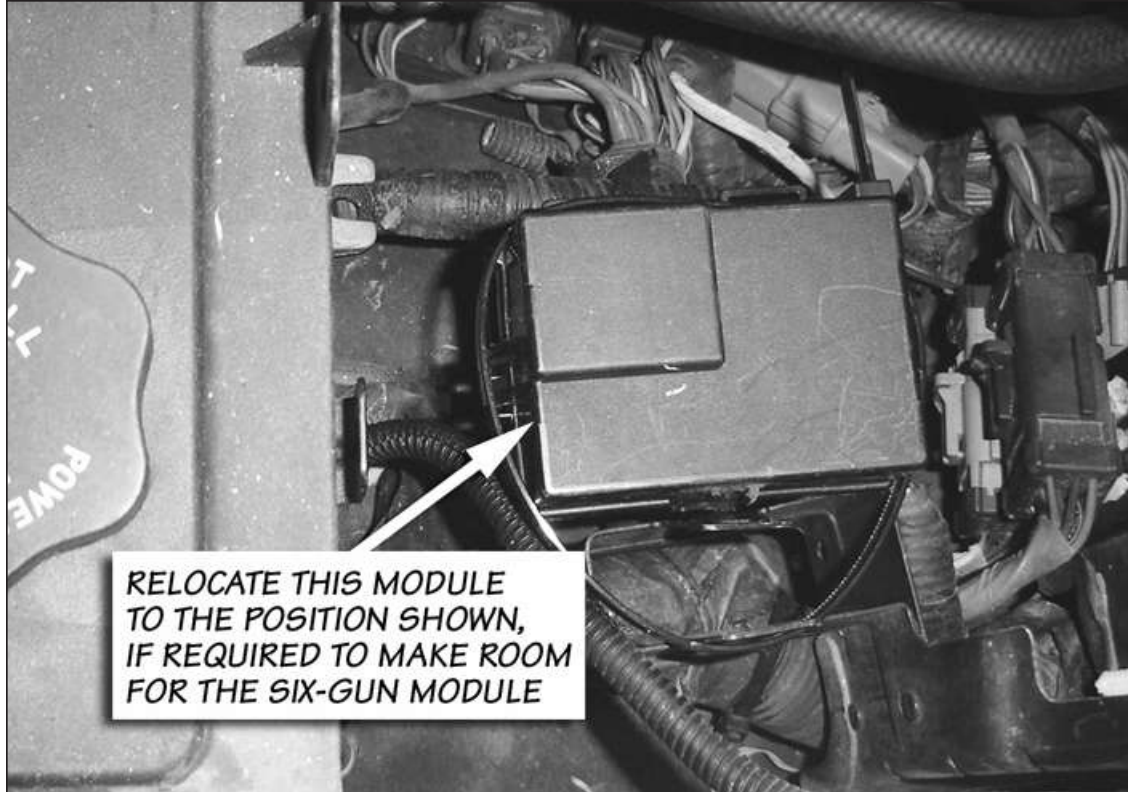

Figure 38



Section 5

MOUNTING AND CONNECTING THE BANKS IQ

If not installing the optional Banks iQ, skip to Section 6.

WARNING: Below 32°F (0°C) or above 140°F (60°C), the Banks iQ may be susceptible to damage as a result of extended direct exposure to sunlight, heat or extreme cold. It is highly recommended that the Banks iQ be removed from its mounting location if the vehicle will be subjected to high concentrations of sunlight, heat or cold for an extended period of time. Gale Banks Engineering is not responsible for damage to Banks iQ resulting from exposure conditions.

CAUTION: Do not use force when working on plastic parts. Permanent damage to the part might result.

1. Locate the Window Mount Assembly in your kit.
2. Assemble the Banks iQ docking station to the Universal mount by inserting and sliding the Universal mount tab into the docking station groove. Hand tighten the nut behind the docking station to hold the docking station in place.
3. Attach the window mount to your Banks iQ. See **Figure 39**. Align and place the two (2) lower tabs on the

window mount to the corresponding slots on the bottom of Banks iQ first then snap the top of Banks iQ into place.

Note: There may be a snug fit when installing the Banks iQ into the window mount. Take care not to force this process.

4. Find a suitable place on the windshield for ease of access and viewing of Banks iQ. Use location shown in **Figure 40** as a reference for mounting Banks iQ in your vehicle. Loosen the knob and move the swivel suction plate to achieve desired viewing angle of the Banks iQ screen. Do a test fit and note the angle necessary to achieve the correct viewing angle.
5. Make sure the suction cup and the mounting area on the windshield are clean and dry. With the suction lever in the up position, ensure the suction cup is flat against the windshield, and then push the suction lever down to secure in place.
6. Next, remove and set the fuse access panel aside. See **Figure 42**.

Note: For 03-04 models the fuse access panel is held in place by four 1/4-turn plastic screws.

If applicable, remove the side access panel to help route wiring to the top of the dash. See **Figure 41**.

7. Locate the Banks OBD II Interface Cable in your kit. This cable has three connection points. Connect the RED OBD II connector on the Banks interface cable to the vehicle OBD II connector. Use a cable tie as shown in **Figure 43** to secure the Banks interface cable to the vehicle OBD II connector. Next, connect the 6-pin connector on the Banks OBD II interface cable to the 6-pin connector on the EconoMind Tuner harness.
8. Locate the RJ12 Cable (similar to telephone connector) on your Banks OBDII interface cable. See **Figure 44**.
9. Locate Banks iQ Bridge Module and connect the RJ12 connector into the Bridge Module. See **Figure 45**.
10. Route the Banks iQ USB interface cable from the Banks iQ Bridge Module under the dash and out through the fuse access panel opening. The cable can be slid under the door frame's seal and run up to the top of the dash. Pull enough cable to reach the Banks iQ and connect it to the USB receptacle on the left side of Banks iQ. See **Figure 40**. Snap the fuse access panel back in place making sure not to pinch the wire.

Figure 39 Attaching Banks iQ to window mount

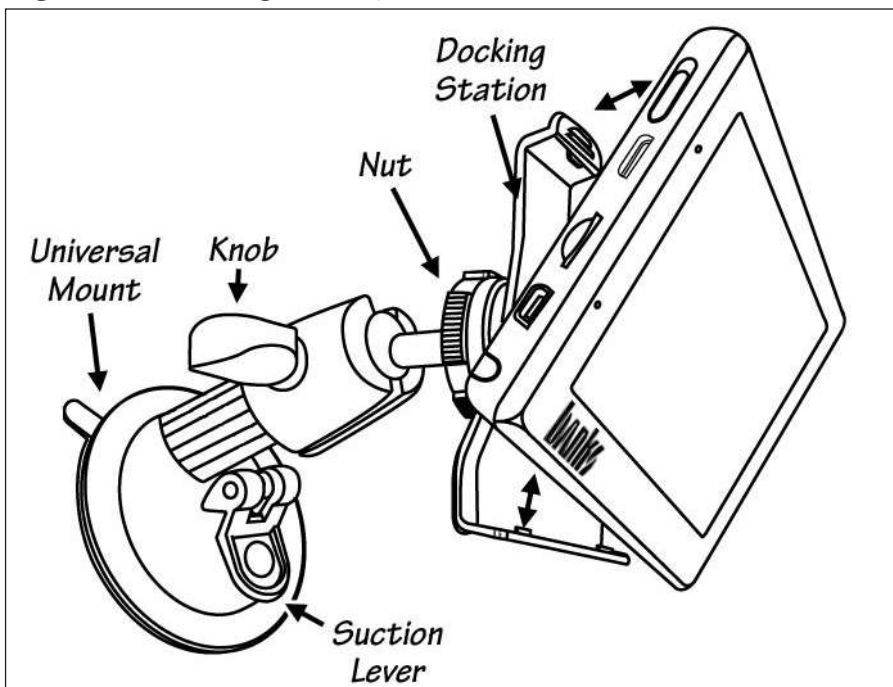

Figure 40 Suggested Mounting location for Banks iQ



WARNING: THE CHARGING CABLE CONNECTED TO THE BANKS iQ IS DESIGNED TO SUPPLY A CONSTANT LOW-VOLTAGE POWER SOURCE (+5VDC) TO THE BANKS iQ AND IS "LIVE" AS LONG AS THE SYSTEM'S OBD II INTERFACE CABLE OR BANKS WIRING HARNESS IS COMPLETELY INSTALLED AND THE USB CABLE CONNECTOR IS PLUGGED INTO BANKS iQ. ALTHOUGH THIS CHARGING CABLE IS SHORT AND ITS CIRCUITRY IS FUSE-PROTECTED, THE USER IS EXPECTED TO TAKE APPROPRIATE MEASURES TO PREVENT SMALL CHILDREN AND/OR PETS FROM CONTACT WITH ANY PART OF THIS SYSTEM.

11. Secure Banks iQ Bridge Module under the dash to any dash frame support using the supplied cable ties. Use the cable tie support loops on the side of the Bridge Module to securely fasten it under the dash.

12. Route all wiring away from any pedals or other moving components. Using the cable ties supplied, secure the wiring under the dash.

13. Reinstall the lower knee panel back in place with the factory hardware. Tuck any excess cable behind it for a clean appearance.

-END, SECTION 5-

Figure 41



Figure 42 Ford ('05-07)



Figure 43



Figure 44 Banks iQ System

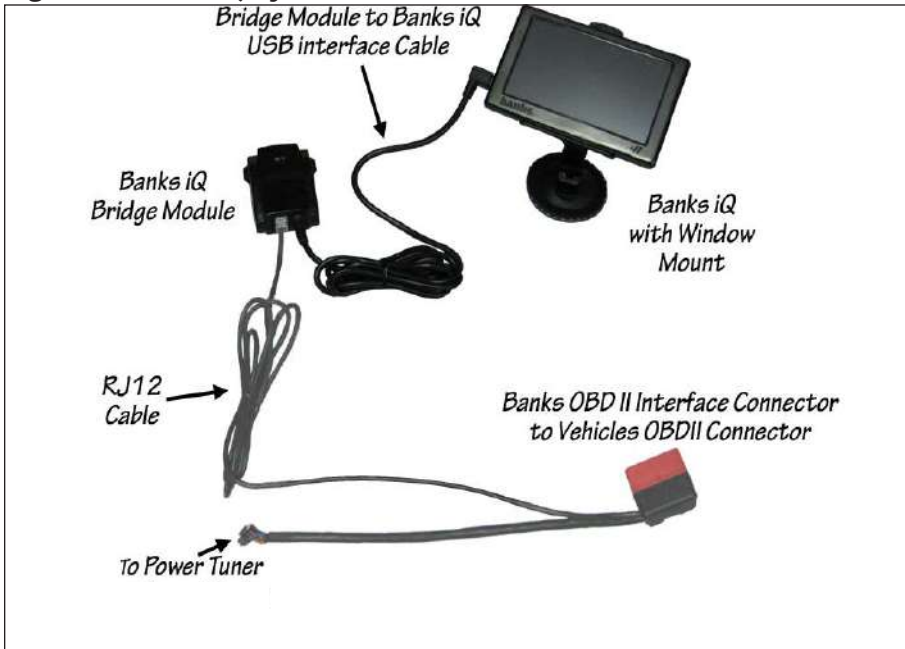
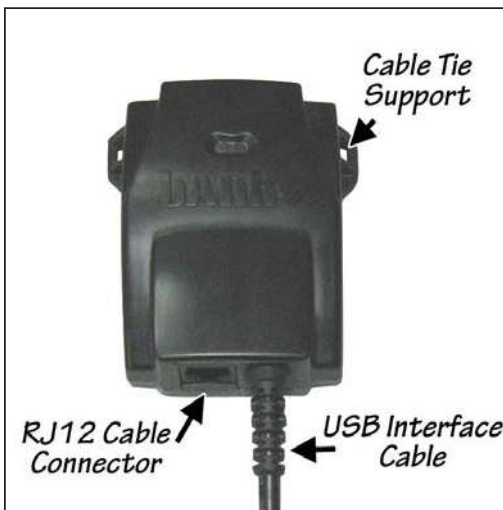

Figure 45 Banks Bridge Module



Section 6

INSTALLATION OF THE POWER LEVEL SELECTOR SWITCH

Not needed if Banks iQ will be installed. Please proceed to **Section 7**.

Caution: Do not use excessive force when working on plastic parts. Permanent damage to the part might result

For 2003-04 model year vehicles, follow the selector switch installation procedure Step 1.

For 2005-07 model year vehicles, skip to Step 7.

1. Remove the lower driver side interior panel that allows access to the fuse box.

2. Remove the stereo using Ford stereo removal tools as shown in **Figure 46**. These are readily available at automotive supply stores.

3. Remove two (2) bolts that reside above the stereo. These are accessible once the stereo has been removed.

4. Detach the dash. At this point the dash is held in place entirely by removable fasteners. Disconnect all electrical connections on the back of the dash once it has been detached.

5. Remove the dash from the vehicle.

6. Cut out the **Template 3** in **Page 41** of this manual and tape to the backside of the dash panel as shown in **Figure 47** for 2003-04 model year. The template will be used as a guide for drilling the holes to locate the Six-Gun selector switch.

For 2003-04 model year vehicles, skip to **Step 9** to finish the selector switch installation procedure.

7. 2005-07 Automatic Transmission vehicles: Set the vehicle's parking brake. Insert the key and turn the vehicle on without starting it. Pull the shift lever down into first gear to allow clearance for dash panel removal.

All 2005-07 vehicles: Pull the plastic trim surrounding the instrument panel and radio / climate controls towards you until it releases from the main dashboard — it is attached by a series of spring clips around its perimeter. Disconnect all electrical connectors from the back of the dash trim and remove it from the vehicle.

8. Cut out the **Template 4** in **Page 41** of this manual and tape it to the front of the dash panel as shown in **Figure 48**. The template will be used as a guide for drilling holes to locate the power level selector switch.

Figure 46 Removal of the stereo (2003-04 model year vehicles only)



Figure 47: Template taped to back of dash on 2003-04 model year vehicle, ready to be drilled.

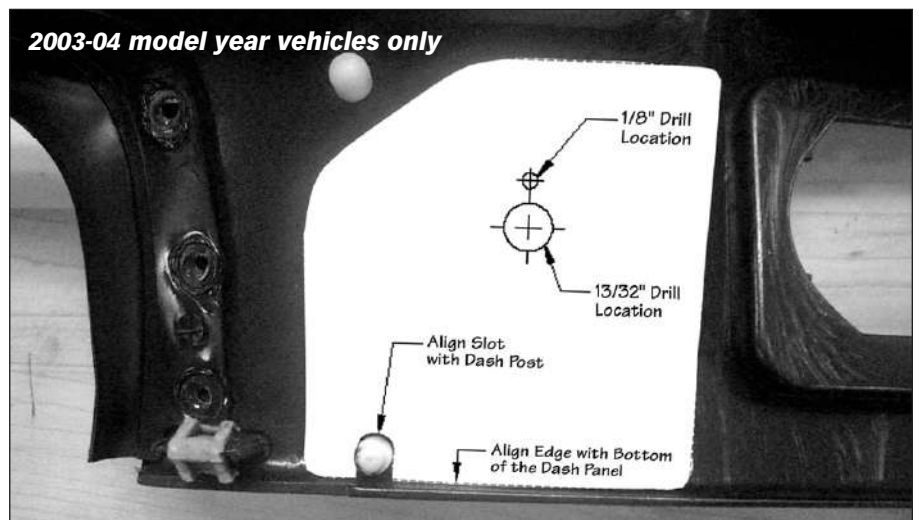

Figure 48 Template taped to front of dash on 2005-07 model year vehicle, ready to be drilled.



9. All model years: Using a $\frac{13}{32}$ " Uni-bit, center the bit onto the $\frac{13}{32}$ " drill location on the template and slowly drill through. Using a $\frac{1}{8}$ " drill bit, center and drill through the $\frac{1}{8}$ " location on the template. Remove and discard the template and any plastic shavings. De-burr the drilled holes as needed to ensure that the power level

selector switch fits squarely against the dash panel.

10. Remove the nut and internal tooth washer from the power level switch and test fit the switch into the drilled holes. Ensure that the alignment pin properly fits in the $\frac{1}{8}$ " hole. Enlarge the holes as necessary to allow the switch to properly fit.

Do not fasten the switch to the dash panel yet.

11. Align the Banks power level switch label on the previously drilled hole on the front of the dash panel. Make sure the entire mounting surface is clean and free of dirt and oil before mounting the label. Clean and dry as required using a cloth dampened with rubbing alcohol or similar cleaning solution. Remove the adhesive backing and affix the label to the dash panel. Hold the label against the panel for approximately 20 seconds while applying pressure to allow the adhesive to properly adhere to the surface.

12. Rotate the switch counterclockwise until the shaft stops. Verify that the washer tab is inserted into the #6 position on the switch as shown in **Figure 49**. Note: All of the power settings may not be usable if the tab is not in slot #6.

13. Install the switch through the $\frac{13}{32}$ " hole on the backside of the bezel. The alignment pin should rest in the $\frac{1}{8}$ " hole and the switch fully rotated counterclockwise. Secure the switch with the internal tooth washer and nut. Snug the nut. Be careful not to over-torque the nut and damage the threads.

14. Install the knob on the shaft facing the #1 Level on the power level switch label. On the knob, snug the two (2) set screws with the supplied 0.050" hex key wrench. The completed switch installation will appear as shown in **Figure 50** for 2003-04 model year and **Figure 51** for 2005-07 model year.

15. Re-install the dash panel, make all electrical connections that were disconnected, and re-install the radio (2003-04 model year vehicles only)

16. Route the Power Level selector switch's cable to the wire harness that was routed into the passenger compartment from the EconoMind Diesel Tuner, and plug the 2-pin connector into the corresponding connector on the EconoMind harness.

Note: The 8-pin plug on the wire harness routed from the EconoMind Diesel Tuner to the passenger compartment will not be used.

17. Reinstall the lower interior panel that allows access to the fuse box.

-END, SECTION 6-

Figure 49: Power Level Selector Switch, orientation of the tab on the washer



Figure 50: Finished installation of the Power Level Selector Switch on 2003-04 model year vehicles



Figure 51: Finished installation of the Power Level Selector Switch on 2005-07 model year vehicles



Section 7

OPTIONAL GAUGE CLUSTER INSTALLATION

If not installing optional gauges, skip to next section.

1. Choose a suitable location under the lower edge of the dash for the mounting of the instrument panel provided where the driver can conveniently view it.

Note: Molded pillar mount and additional gauges are available through Gale Banks Engineering.

2. Using the panel as a template, drill two 3/16" diameter holes in the

dash and mount the panel with the supplied machine screws, nuts and star washers provided.

3. Locate the supplied EconoMind wire loom with the 4-pin connector. Connect the 4-pin connector on the EconoMind wire loom to the connection labeled DYNAFACT Gauges on the EconoMind wiring harness. See **Figure 26**.

4. Install the DynaFact boost and pyrometer gauges in the mounting panel using the clamps and

thumbnuts provided. Plug the BLACK wire lead to the male spade terminal on the BLACK wire of each gauge wire harness. Plug the YELLOW wire into the Yellow wire of the boost gauge wire harness and the RED wire into the RED wire of the pyrometer gauge wire harness. The ORANGE wire remains unused.

5. Connect the 4-pin connector of each gauge into the back of its corresponding gauge.

a. Crimp the remaining Black and RED wires from each 4-pin connector gauge harness to the butt connectors as shown in **Figure 52**.

b. Strip one end of the RED wire and crimp it to the butt connector containing the RED wires from step 'a'.

c. Strip one end of the BLACK wire and crimp it to the butt connector containing the BLACK wires from step 'a'.

d. Route the RED wire to the fuse box. Locate the appropriate fuse for instrument lighting in the owner's manual. Cut the RED wire as required and strip the end. Crimp the push on connector to the RED wire and connect to the fuse as shown in **Figure 52**. Alternatively, locate power wire to dimmer switch and install T-tap. Cut the RED wire as required and strip the end. Crimp the push on T-tap connector to the RED wire and connect to T-tap on dimmer power wire.

e. Locate a metal surface that will serve as an acceptable chassis ground. Cut the BLACK wire to a sufficient length that will allow it to reach the chassis ground and strip the end. Crimp the ring terminal to the BLACK wire as shown in **Figure 52**.

f. Drill a 1/8" hole, if required, to attach the ring terminal to the chassis ground. **Caution: If drilling, check the backside to make sure there are no components that may be damaged by drilling.**

g. Use the supplied self-tapping screw to secure the ring terminal to the chassis ground

-END, SECTION 7-

Figure 52

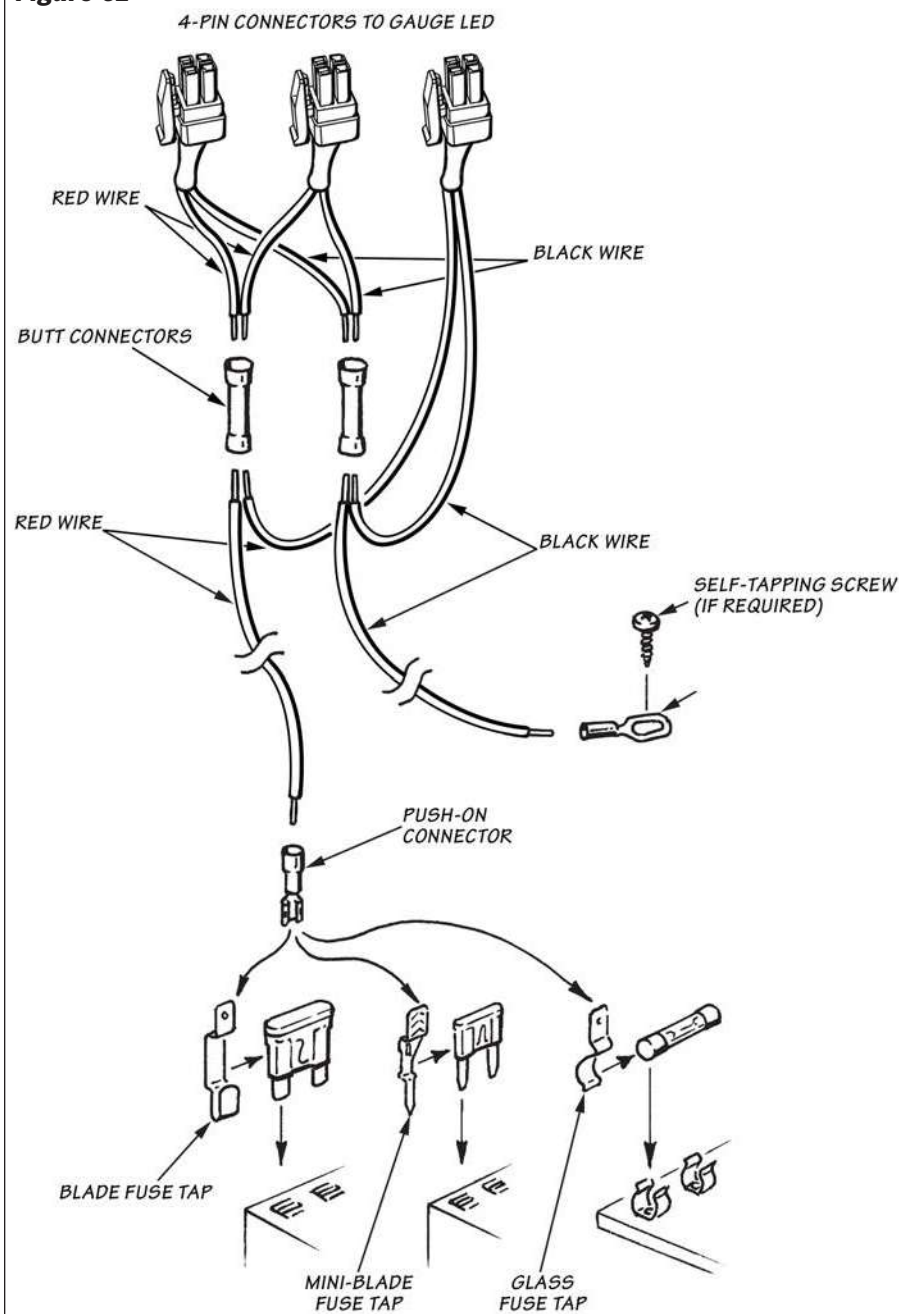

Section 8

AUTOMATIC TRANSMISSION LEARNING

Note: If installing Banks iQ, then refer to the Banks iQ Software & Installation Kit, Owners Manual for software installation and operation instruction before beginning Section 8, Automatic Transmission Learning.

The 6.0L Ford Trucks equipped with the TorqShift™ 5-speed automatic overdrive transmission use an adaptive shift control logic. This will require the transmission to learn how to cope with the additional power created by the Banks Power products before it will shift properly. Additionally, the EconoMind Diesel Tuner will require a short learning curve to characterize the transmission in order to optimize fueling during gear change events. The following sequence must be followed to allow for collaborative learning between the EconoMind and the transmission's control system. Failure to follow the sequence can result in damage to the transmission.

Perform the following sequence at a location where it is safe to accelerate to 60 mph without exceeding the posted speed limit.

1. Start the truck and allow the engine to reach normal operating temperature.
2. Set the Banks iQ or EconoMind switch to power level 2.
3. Accelerate with the pedal to the floor, from a standing start to 60 mph. Repeat three (3) times.
4. Cruise at 30 mph, then press the accelerator to the floor to cause the transmission to downshift. Continue accelerating to 60 mph.
5. Repeat steps (3) and (4) for the next power setting.
6. Continue to increase the power setting and drive cycle until the desired power setting is achieved.

The TorqShift™ 5-speed automatic transmission will continually adapt to the power output of the engine to optimize shift quality. This will result in the transmission un-learning how to cope with the higher power settings of the EconoMind Diesel Tuner, if the EconoMind Diesel Tuner is returned to a lower power setting. The rate that the transmission un-learns how to cope with the higher power levels,

when switching to a lower power level, depends on the driving cycle. The transmission will quickly adapt to the power setting if the driving cycle includes regular gear changes at high loads. The transmission learning procedure will need to be repeated when switching back to the higher power settings once the transmission adapts to the lower power settings. It will be apparent when the transmission adapts to the lower settings by monitoring the feel of the gearshift. Gear changes will be noticeably harder when initially switching from a higher to lower power setting. This will soften as the transmission adapts to the new setting.

For example: If the transmission has adapted to level 3 and it is desired to go to level 6, the transmission learning procedure can start at level 3.

IF TRANSMISSION SLIP IS DETECTED DURING THE TRANSMISSION LEARN PROCESS, REDUCE THE POWER LEVEL BY ONE, AND START OVER AT **STEP 3**.

-END, SECTION 8-

Section 9

TROUBLESHOOTING, ECONOMIND

EconoMind Troubleshooting Using The Banks iQ

Check the Banks iQ's Status indicator for the "OK" icon on the upper left corner of the iQ screen. Any Tuner fault will be indicated by the "Banks Engine" icon (see **Figure 53**) and its cause can be investigated by running a 'Tuner Diagnostic' from the Diagnostic menu.

Figure 53



*Banks Engine
Icon*

1. In the Environment select menu press on the 'Diagnostics' button. See **Figure 54**.

2. In the Diagnostics menu press on the 'Tuner Diagnostics' button to run a tuner diagnostics. See **Figure 55**.
3. The 'Self Diagnostic' screen displays a log of diagnostic events related to the Power Tuner. The 'Logged Events' list takes a moment to update each time this screen is opened. Once the list is updated, the most current event will appear at the bottom of the list. Each event has an associated timestamp and description, which will be displayed below the list when that event is highlighted. Each key cycle of the vehicle produces a minimum of two logged events. See **Figure 56**. Table 1 lists the common diagnostic codes and the suggested course of action for each.

4. Use the arrow buttons to scroll through the recorded events.
5. Touch the Banks iQ icon on the lower left of the screen to return to the environment screen or the return icon to return to the Diagnostics menu.
6. A pop-up "Log-File" screen will appear asking you if you want to erase the contents of the log. Press 'No' to keep the contents on Log-file or 'Yes', to erase the Log-files.

Diagnosing EconoMind error codes without Banks iQ

If you feel that your Banks EconoMind Diesel Tuner is not functioning properly, some diagnostics can be performed. Your EconoMind Diesel Tuner is equipped with diagnostic features that will detect and display certain errors.

Remove the Banks EconoMind Diesel Tuner from its mounting location while keeping all connectors plugged in, and position it in such a way that you can view the top of the EconoMind housing that contains the LEDs. Turn the vehicle key to the ON position. Observe the two LEDs mounted on the end of the Banks EconoMind Diesel Tuner:

- A steady GREEN LED will illuminate if all wire connections are correct, the engine is running, and the engine coolant temperature is within its normal operating range.
- The GREEN LED will flash if all wire connections are correct, the engine is running, but the engine coolant temperature is not within its normal operating range. The GREEN LED will stop flashing once the engine coolant temperature is within its normal operating range.
- No LEDs will illuminate if the fuse on the EconoMind wiring harness is blown or the wiring harness is not properly connected. If the fuse and all connections are okay, contact Banks Technical Service.

• The RED LED will flash in a certain sequence if a connection is incorrect or if there is a problem with the system – this sequence will identify one or more diagnostic codes. A Banks EconoMind Diesel Tuner's diagnostic code is comprised of 2 digits. Each code is expressed in a sequence of 2 sets of the flashing red LED separated by a brief flashing of the green LED in between. Each set of a number of red LED flashes represents a digit. A longer flashing of the green LED separates the sequences. The LEDs will continue to flash to display all the errors, and then repeat. **Table 1** lists the common diagnostic codes. For example, if a faulty thermocouple is detected (code "2,3") by the Banks EconoMind Diesel Tuner, the following red and green LED flashing sequence is observed when the key is on:

Figure 54



Figure 55

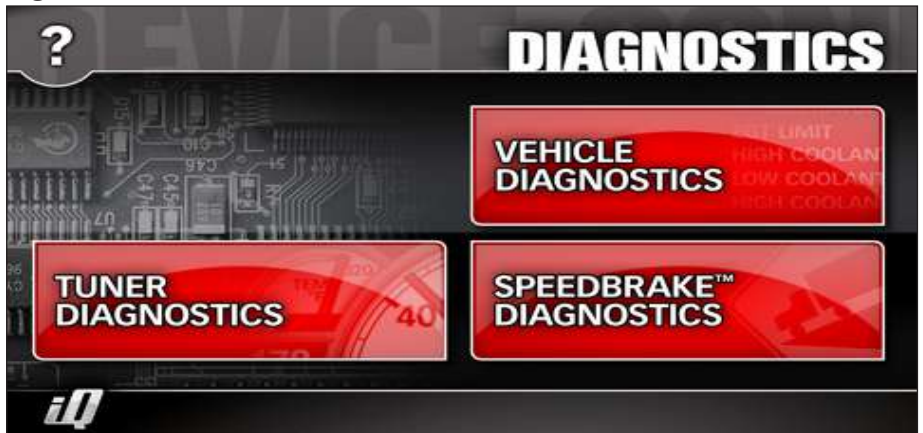

Figure 56



- (1) Two times flashing RED LED
- (2) One time quick flashing GREEN LED
- (3) Three times flashing RED LED
- (4) One time longer flashing GREEN LED

The above flashing sequence will repeat continuously. When the problem is corrected, the diagnostic

code will be eliminated and replaced by a steady green light.

NOTE: If multiple codes are set, they will be displayed in a series separated by the longer flashing green LED. When reading codes, make sure to watch the entire series until you see the first code repeat.

-END, SECTION 9-

Table 1 Banks EconoMind Diagnostic Codes

	Event	Course of Action
1,1	Faulty Injection Control Pressure (ICP) input signal.	Check the 46-Pin connectors. Reset EconoMind Diesel Tuner by turning key on and off.
1,2	Faulty Manifold Absolute Pressure (MAP) input signal.	Check 3-pin MAP sensor connections. Reset the EconoMind Diesel Tuner by turning key on and off.
1,3	Faulty EconoMind signal Input	Make sure the EconoMind switch is connected to the main wire harness. Reset EconoMind Diesel Tuner by turning the key on and off.
2,1	Faulty Injection Control Pressure (ICP) output signal.	Check the 46-Pin connectors. Reset EconoMind Diesel Tuner by turning key on and off.
2,2	Faulty Manifold Absolute Pressure (MAP) output signal.	Check 3-pin MAP sensor connections. Reset the EconoMind Diesel Tuner by turning key on and off.
2,3	Faulty Thermocouple signal	Check thermocouple connection
3,2	Power Up Error or Internal Module Malfunction.	Turn ignition OFF and check fuse-tap power connection to EconoMind Diesel tuner (under-dash panel). Turn ignition back ON and re-check for presence of code.
3,3	Internal Module Malfunction	Check the 46-Pin connectors. Reset EconoMind Diesel Tuner by turning key on and off.
3,4	CAN Communications Error With Vehicle ECM, ICM or OBD System.	Turn ignition OFF and check the 46-Pin Connectors and the in-cab OBD II connection. Turn ignition back ON and re-check for presence of code.
4,2	Transmission Slippage Detected.	Transmission is slipping excessively. Code will automatically clear once transmission stops slipping (repaired).
4,3	Faulty Exhaust Back Pressure (EBP) input signal	Check the 46-Pin connectors. Reset EconoMind Diesel Tuner by turning key on and off.
4,4	Faulty Exhaust Back Pressure (EBP) output signal	Check the 46-Pin connectors. Reset EconoMind Diesel Tuner by turning key on and off.
5,1	Internal Module Malfunction	Check the 46-Pin connectors. Reset EconoMind Diesel Tuner by turning key on and off.

If problem persists, call Gale Banks Engineering Tech Support.

Section 10

REMOVAL OF THE ECONOMIND DIESEL TUNER

If the EconoMind Tuner should ever need to be removed from the vehicle, perform the following:

Note: The ignition must remain in the OFF position throughout the removal process.

1. Disconnect the EconoMind 46-pin connector (connector C) from the middle connection on the PCM.
2. Re-connect the vehicle's 46-pin connector back into the middle connection on the PCM.

3. Disconnect the EconoMind MAP connections from the vehicles MAP sensor and harness. Re-connect the vehicle's MAP connector back into the MAP sensor.

4. Disconnect the 2-ring terminals from the EGT thermocouple.

5. Disconnect the 3 small connectors on the 'In-Cab Cable' and gently pull the cable back through the firewall.

6. Remove the EconoMind Tuner.

Failure to follow the above instructions when removing the module will result in a "Check Engine" light on the dash and a Diagnostic Trouble Code being stored in the factory computer, in addition to the engine not running.

-END, SECTION 10-

Section 11

PLACEMENT OF THE BANKS POWER DECAL

Figure 55: Placement of the Banks decals

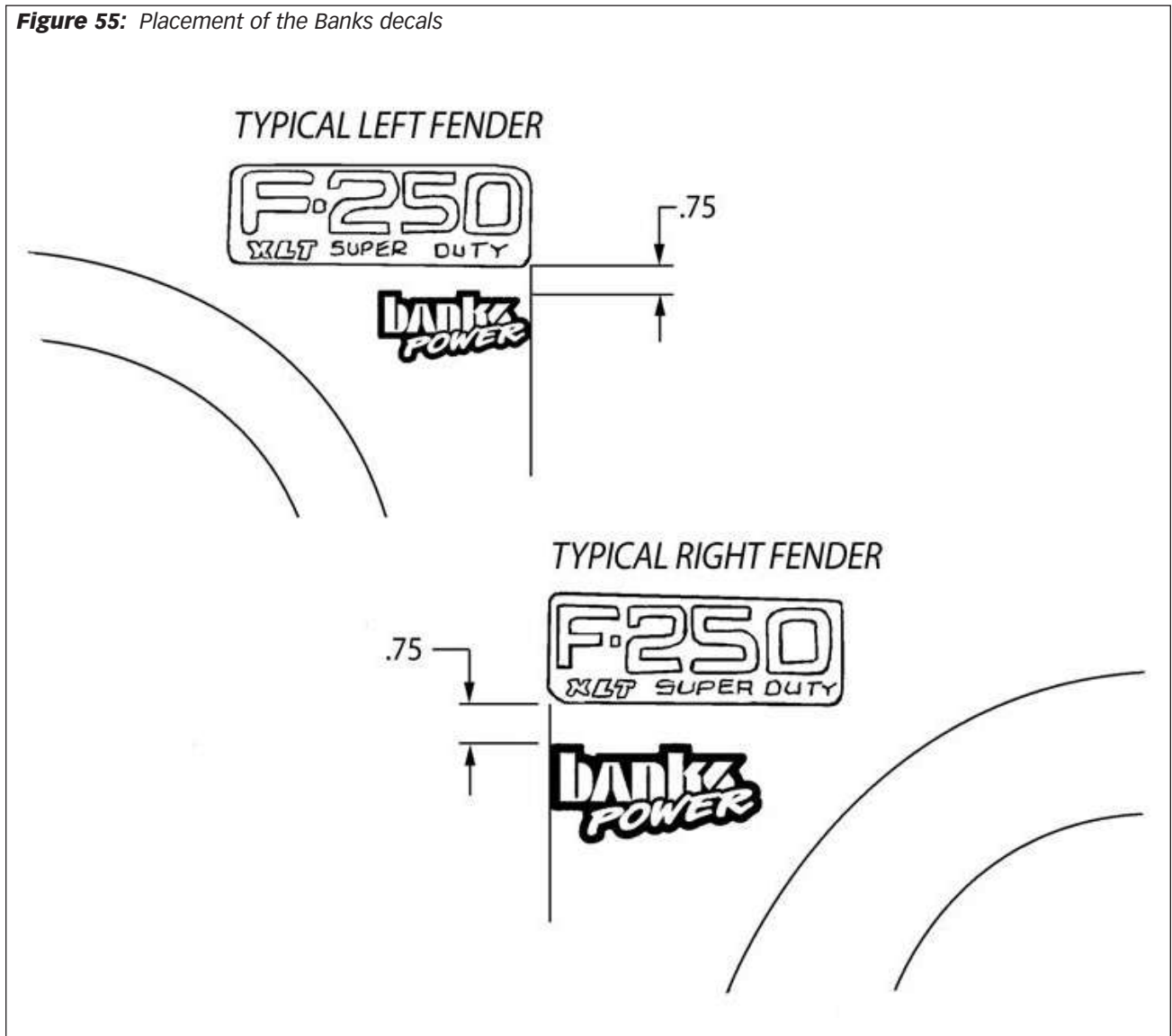

Template 1 (fan shroud, step 34)

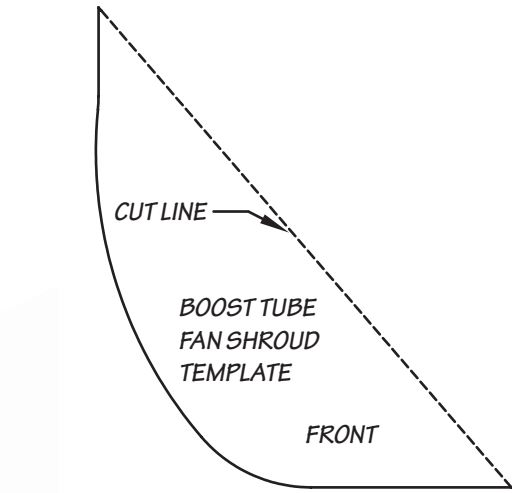

Template 2 (fan shroud, step 35)

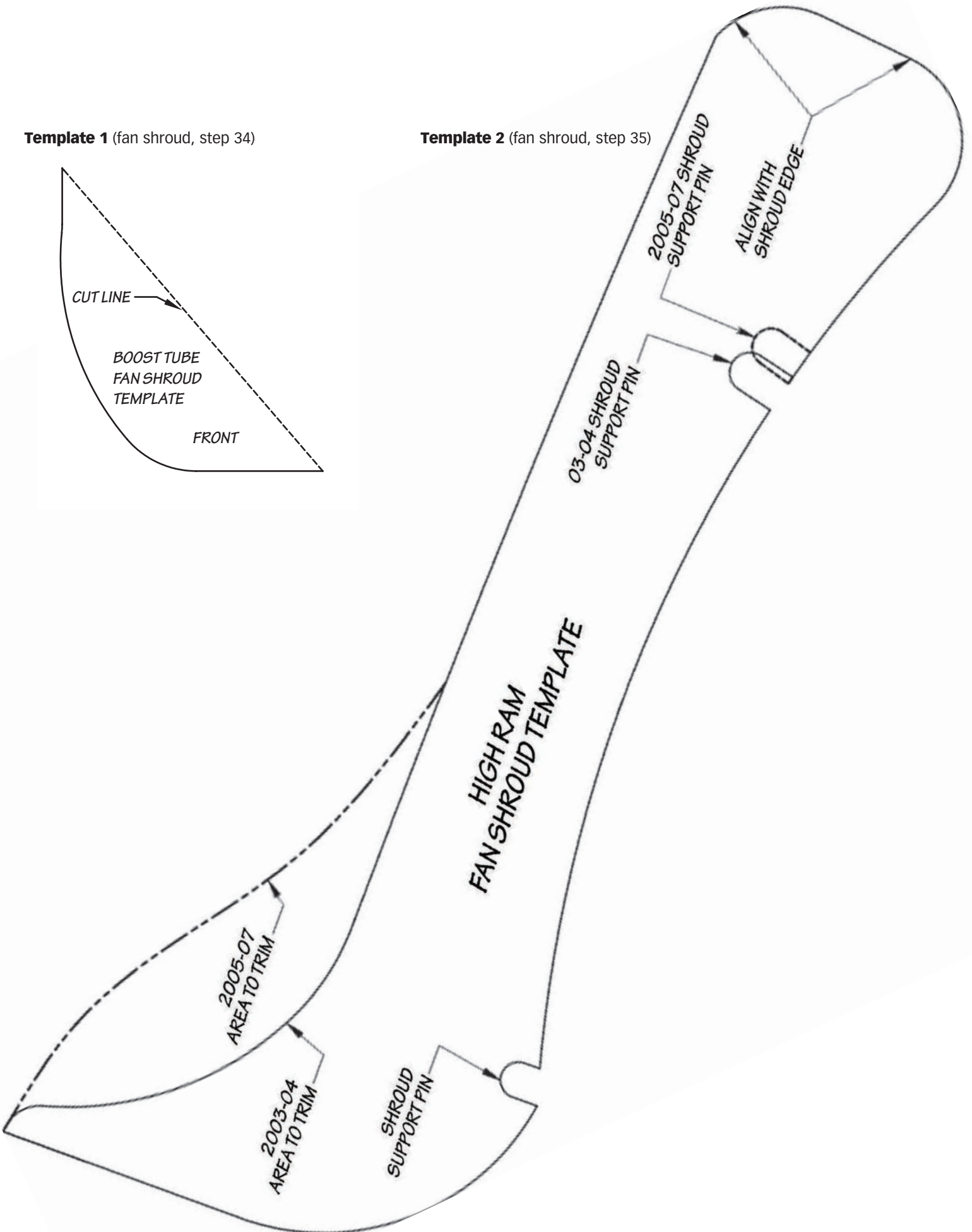

Template 3: Templates for locating the power level switch on the dash panel.

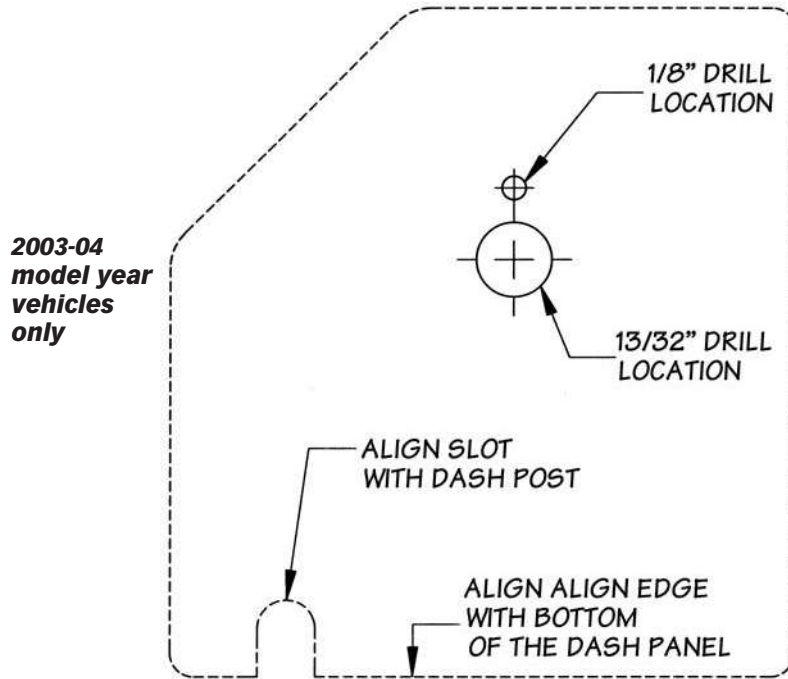

Template 4: Templates for locating the power level switch on the dash panel.

