



Owner's Manual with Installation Instructions

Banks PowerPack® System

Compatible with Optional Banks iQ™

**Including Stinger® System
& EconoMind**

**2006-2007 Chevy/GMC 6.6L Duramax
Turbo-Diesel Pickups LLY-LBZ**

THIS MANUAL IS FOR USE WITH SYSTEM 47763-47782, 63863-63867, 63857, 63858



General Installation Practices

Dear Customer, if you have any questions concerning the installation of your Banks PowerPack system, please call our Technical Service Hotline. If you have any questions relating to shipping or billing, please contact our Customer Service Department.

Thank you.

1. For ease of installation of your Banks system, familiarize yourself with the procedure by reading the entire manual before starting work.
2. The exploded illustrations provide only general guidance. Refer to each step and section diagram in this manual for proper instruction.
3. Throughout this manual, the left side of the vehicle refers to the driver's side, and the right-side to the passenger's side.

4. Disconnect the ground cable from the battery before beginning work. If there are two batteries, disconnect both.
5. Route and tie wires and hoses a minimum of 6 inches away from exhaust heat, moving parts and sharp edges. Clearance of 8 inches or more is recommended where possible.
6. During installation, keep the work area clean. If foreign debris is transferred to any Banks system component, clean it thoroughly before installing.
7. When raising the vehicle, support it on properly weight-rated safety stands, ramps or a commercial hoist. Follow the manufacturer's safety precautions. Take care to balance the vehicle to prevent it from slipping or falling. When using ramps, be sure the front wheels are centered squarely on the topsides; put the transmission in park; set the parking brake; and place blocks behind the rear wheels.

CAUTION! Do not use floor jacks to support the vehicle while working under it. Do not raise the vehicle onto concrete blocks, masonry or any other item not intended specifically for this use.

8. The Banks iQ displays a green indicator light when the battery is fully charged. If an orange light is displayed, the Banks iQ can be charged with the supplied AC-outlet wall charger. Locate the supplied AC-outlet wall charger, also located in your kit and plug the charging cord into the Banks iQ. *Please refer to the Banks iQ DashBoard PC, Owners Manual for additional instruction.*

WARNING: Below 32° F (0°C) or above 140° F (60°C), the Banks iQ may be susceptible to damage as a result of extended direct exposure to sunlight, heat, or extreme cold. It is highly recommended that the Banks iQ be removed from its mounting location if the vehicle will be subjected to these conditions for an extended period of time. Gale Banks Engineering is not responsible for damage to Banks iQ resulting from exposure conditions.

General Assembly Diagram BANKS POWER PACK SYSTEM

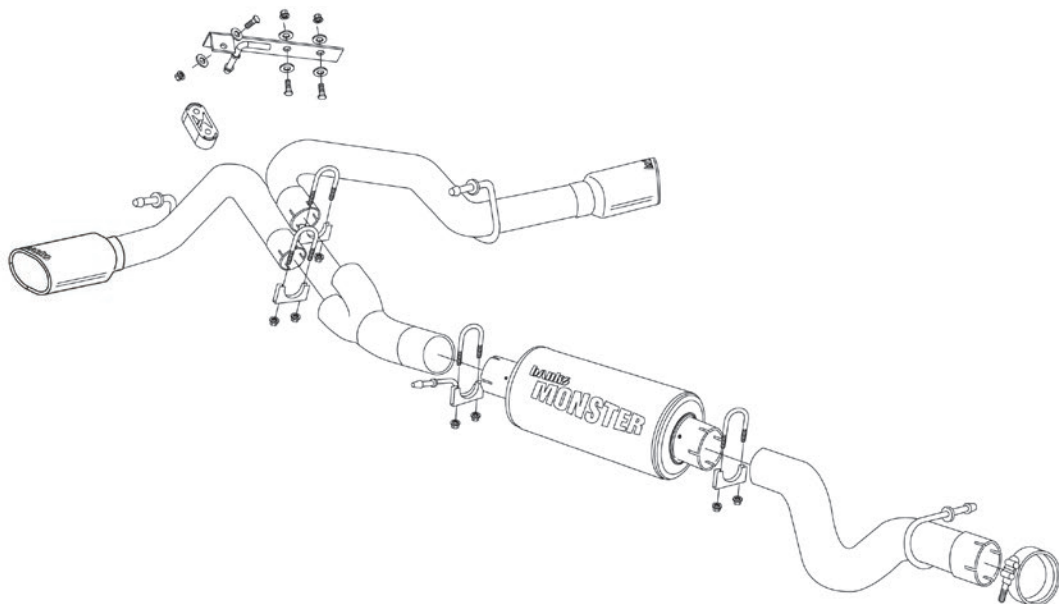

Tools Required:

- 1/4" and 3/8" drive ratchets
- Inch and metric deep sockets
- Ratchet extension
- Metric combination or open-end wrenches
- Phillips and flat blade screwdrivers
- Standard and needle-nose pliers
- Pocket or X-Acto knife
- Clean shop towels or rags
- Drill bit set
- Drill motor
- Tap Handle
- 1/4" NPT tap
- 5/16 nut driver
- Pliers
- Torx bits
- Pry-bar

Highly recommended tools and supplies:

- Multimeter or 12-volt test light
- Heat gun
- Foot-pound torque wrench
- Penetrating oil or light lubricant spray
- Reciprocating saw
- Inch-pound torque wrench

Notification

The Banks Ram-Air Filter comes pre-oiled and no oiling is necessary for initial installation. Service the filter as specified in the Filter Maintenance Section of this manual.

Table of Contents

General Assembly Diagram

Banks Power Pack System

Section 1

Installation of Banks Monster Exhaust System

Section 2

Techni-Cooler Assembly Installation

Section 3

Thermocouple Installation

Section 4

Banks Ram-Air Intake System

Section 5

Banks EconoMind Diesel Tuner Installation

Section 6

Mounting and Connecting the Banks iQ

Section 7

Installation of the Power Level Selector Switch

Section 8

Optional Gauge Cluster Installation

Section 9

Automatic Transmission Learning

Section 10

Troubleshooting, EconoMind

Section 11

Clearing Learned Parameters

Section 12

Removal of the EconoMind Diesel Tuner

Section 13

Filter Maintenance

Section 14

Placement of the Banks Power Decals

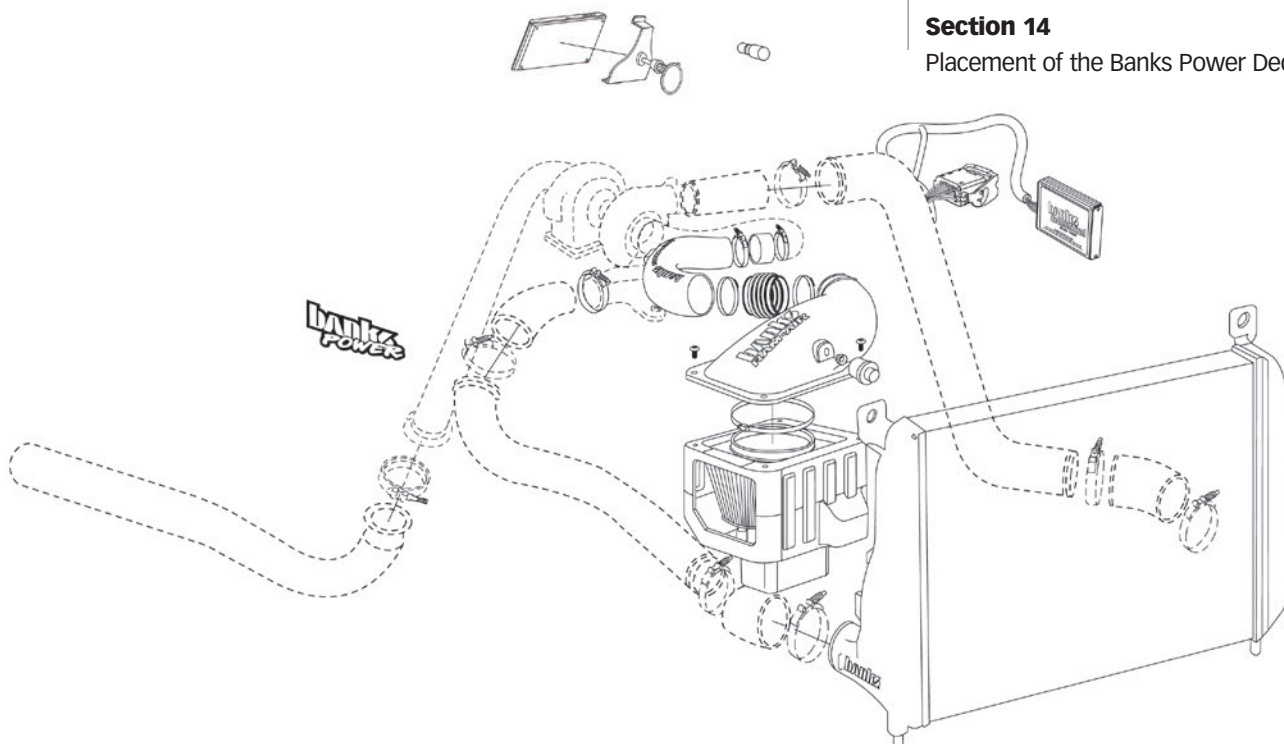

Section 1

INSTALLATION OF BANKS MONSTER EXHAUST SYSTEM

Figure 1.0
 General Assembly
 Banks Monster Exhaust (Single Tailpipe)

Item	Description	Part #	Qty.
1	Monster Muffler		
	Ext./Crew Cab short Bed/Std Cab Long Bed	53800	1
	Ext./Crew Cab Long Bed	53801	1
2	Intermediate pipe		
	Std Cab Long Bed	53733	1
	Ext. Short Bed	53734	1
	Crew Cab Short Bed	53735	1
	Ext. Long Bed	53736	1
	Crew Cab Long Bed	53737	1
3	Tailpipe		
	Ext./Crew Cab Short Bed/Std Cab Long Bed	53708	1
	Ext./ Crew Cab Long Bed	53709	1
4	Polished 5-inch exhaust tip with clamp	52383	1
5	4" Exhaust hanger/clamp (saddle type)		
	Ext./Crew Cab Long Bed	53707	1
6	4" Band clamp	52471	1 **
7	4" Exhaust clamps (saddle type)	52470	3 *

*LLY models & LBZ Ext./Crew Cab Long Bed only receive (2). LLY Ext./Crew Cab Long Bed only receive (1).

** Excludes LBZ (2006-2007) models.

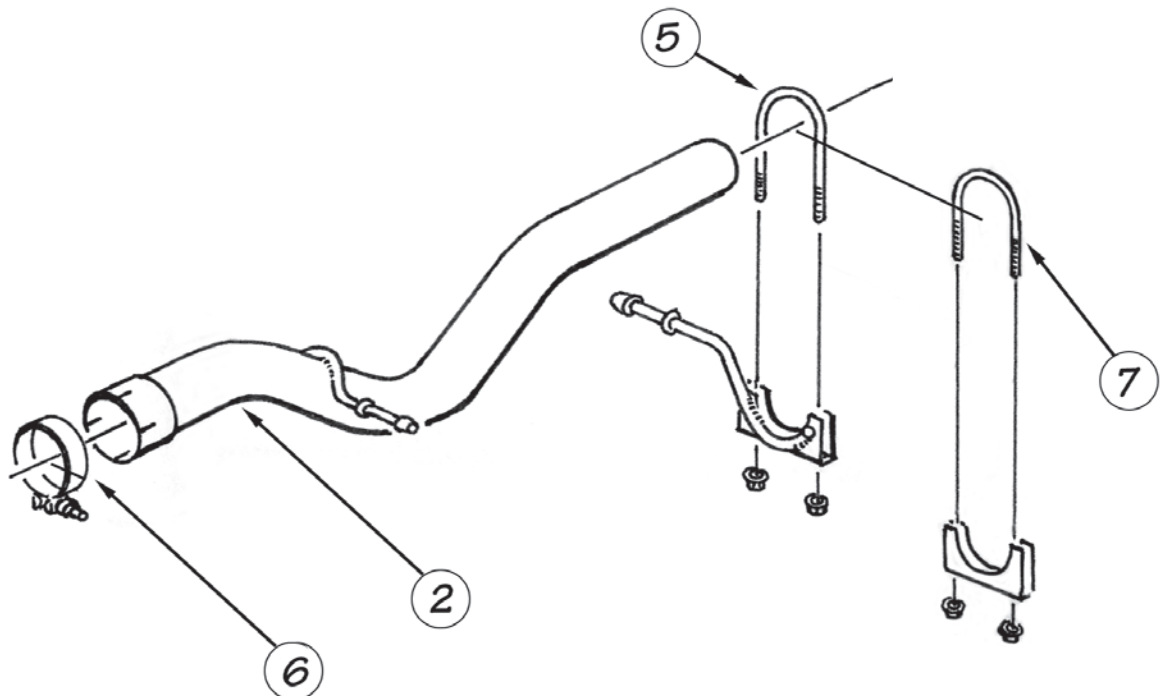

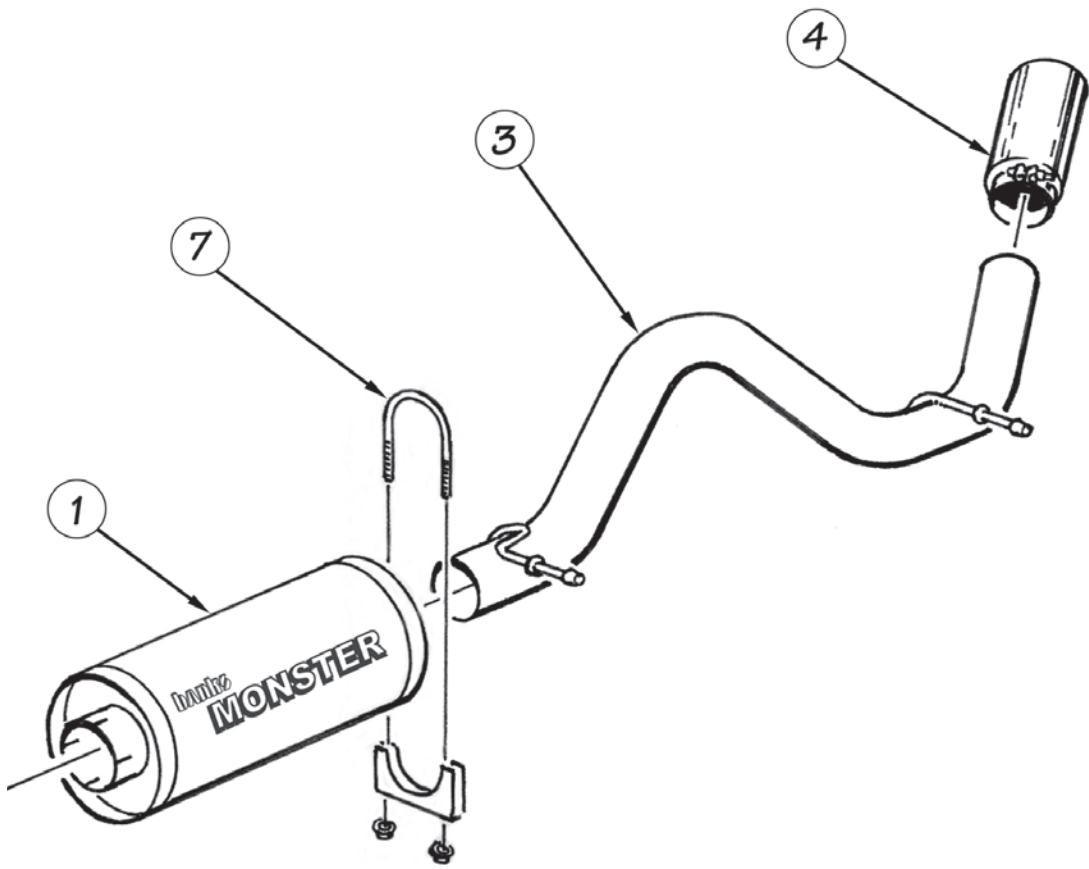
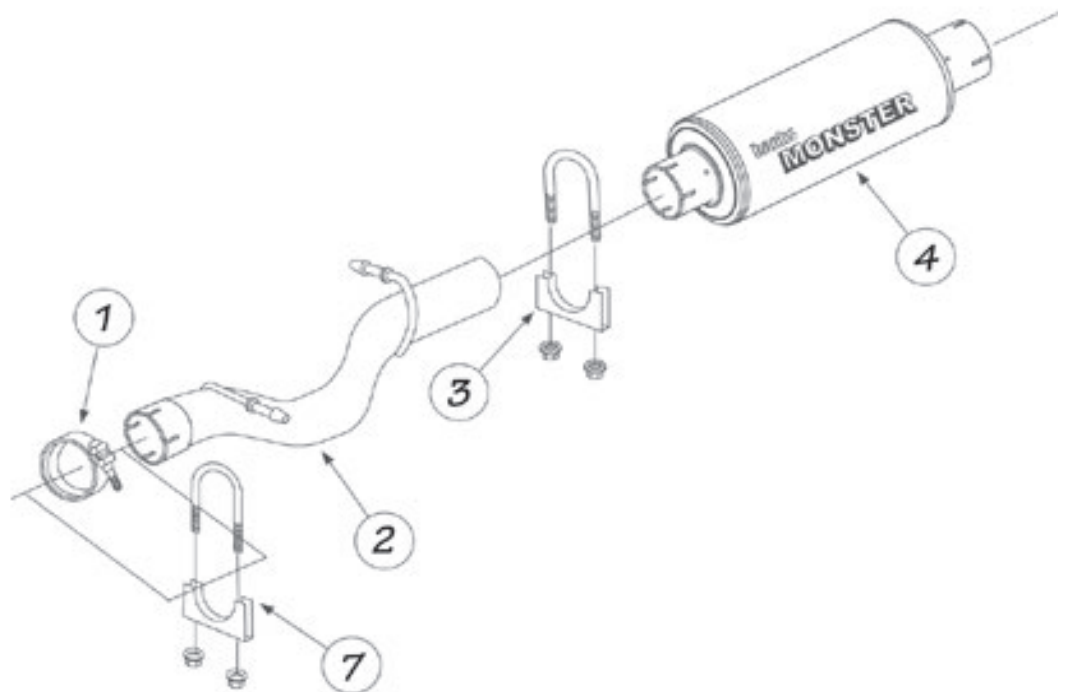

Figure 1.1
 General Assembly
Banks Split-Dual Monster Exhaust, Split-Dual

	Description	P/N	Qty.
1	4" Band clamp	52471	1 *
2	Intermediate pipe		
	Std. Cab Long Bed	53738	1
	Ext. Cab Short Bed	53734	1
	Crew Cab Short Bed	53740	1
	Ext. Cab Long Bed	53741	1
	Crew Cab Long Bed	53742	1
3	4" Saddle clamp	52476	1
4	Monster Muffler	53800	1
5	Rear Muffler hanger/clamp	53726	1
6	Y-pipe, Split Dual	53727	1
7	3.5" Saddle clamp	52467	3**
8	Driver side tailpipe	53743	1
9	Passenger side tailpipe	53744	1
10	Driver side frame hanger bracket	53731	1
11	Driver side rubber insulator	53732	1
12	1/2 -13 x 1.0" Bolt	91930	2
13	1/2 SAE washer	91902	4
14	1/2 -13 Nylock nut	91823	2
15	5" Black cable tie	62001	3

* Excludes LBZ (2006-2007) Models

** LLY models only receive (2)



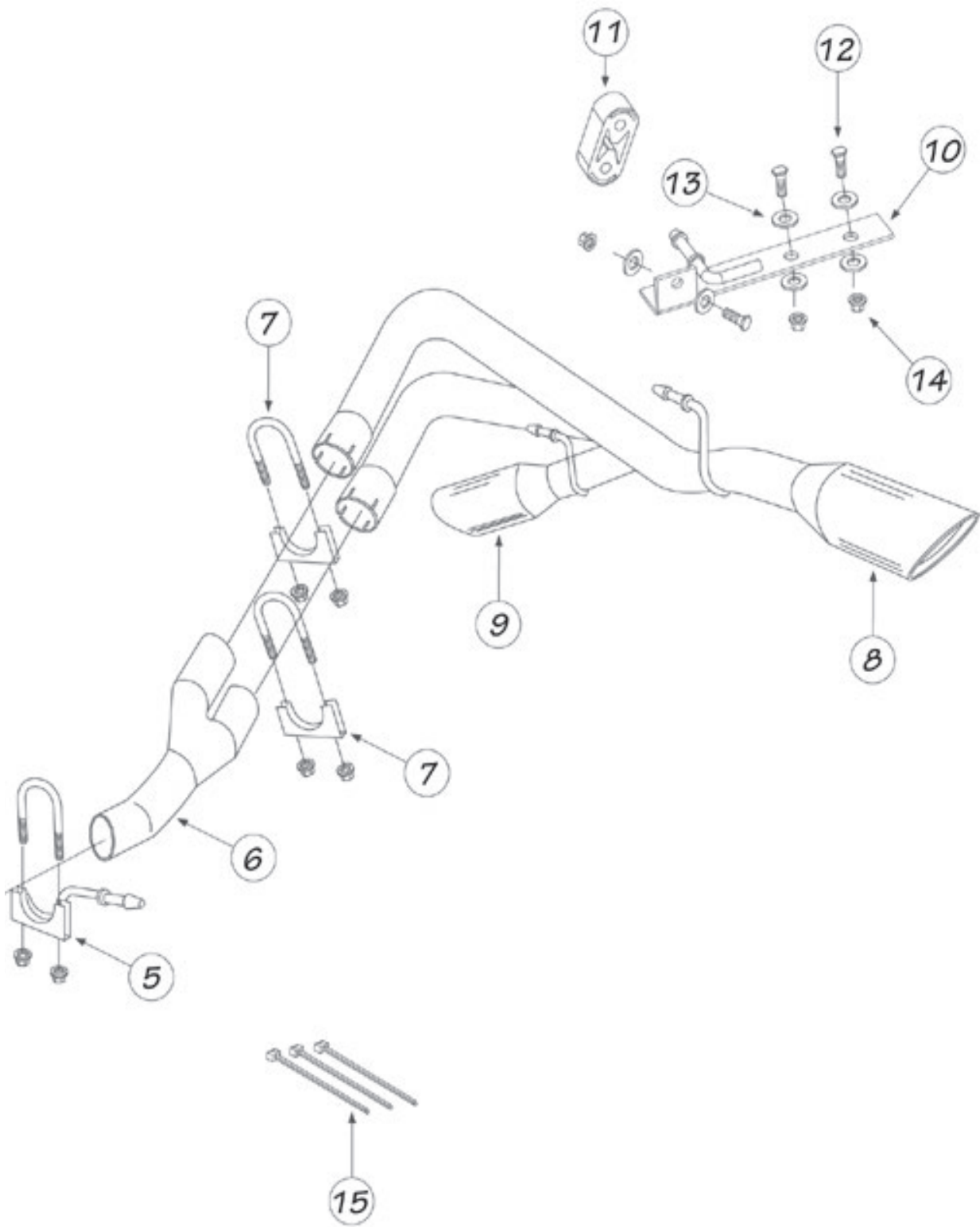

EXHAUST SYSTEM INSTALLATION

Use the Bill of Materials Chart and **Figure 1.0** or **1.1** to reference component nomenclature and location. Use caution when working in the engine compartment. Make sure the engine has been OFF for several hours and cool.

1. Disconnect the ground of the battery (if there is more than one battery, disconnect both).
2. Raise the vehicle and support it with properly weight rated safety stands, ramps or a commercial hoist. Follow the manufacturer's safety precautions. Take care to balance the vehicle to prevent it from slipping or falling. When using ramps, be sure the front wheels are centered squarely on the topsides; place the transmission in park; set the parking brake and place blocks behind the rear wheels.

CAUTION: DO NOT WORK UNDER ANY VEHICLE SUPPORTED ONLY BY A JACK. SEVERE INJURY MAY RESULT.

CAUTION: The following step involves cutting a stainless steel tube. Safety glasses should be worn during any cutting operation and care should be taken to avoid injury due to sharp edges and burrs.

3. Removal of the factory exhaust can be simplified by cutting the factory exhaust pipe behind the muffler. This will allow the tailpipe to be removed as a separate piece.
4. Remove the clamp located on catalytic converter outlet
5. Remove the factory tailpipe from the vehicle by disengaging the exhaust system hanger pins from the rubber insulators using a large screw-driver or pry bar.

NOTE: Lubricating the rubber hangers with WD-40 or similar lubricant will ease removal of the hanger pins.

6. Remove the factory muffler from the vehicle by disengaging the hanger pins from the rubber insulators using a large screwdriver or pry bar.
7. Install a 3.5" saddle clamp onto the catalytic converter outlet.
8. Insert the intermediate pipe inlet onto the flanged intermediate pipe outlet. Install the intermediate pipe

Figure 1.2

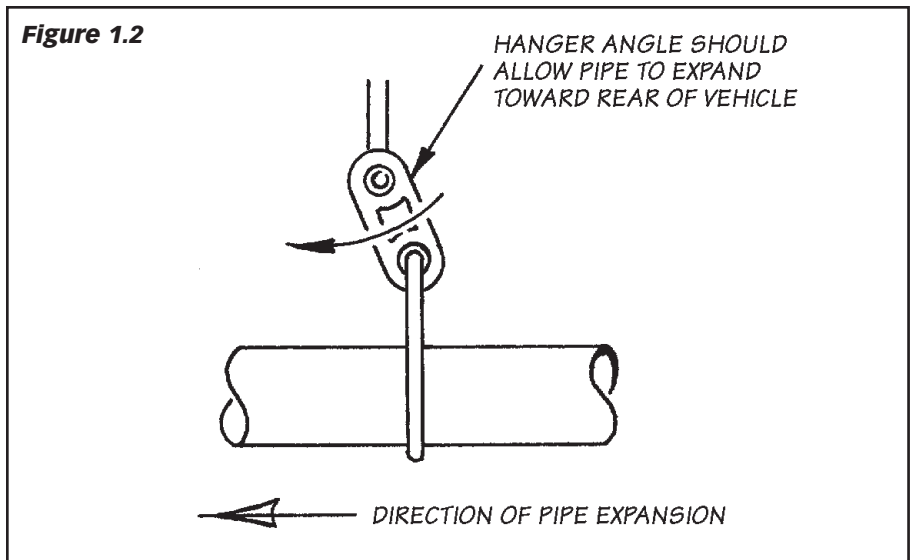

hanger pin(s) into the vehicle rubber insulators.

NOTE: Once the pipe has been completely engaged in the slip joint, it should be marked with a marker, scribe or tape for reference when tightening clamps later in the installation. Each slip joint in the system should be marked in this fashion. When the exhaust system is being adjusted to align the hangers, the slip joints can be adjusted so that the reference mark is no more than 1/4" away from its original position.

Step 16 thru 23 applies only to single tailpipe systems.

Skip to Step 24 if installing Banks Split-Dual Monster Exhaust System.

Single Tailpipe System (Step 9 thru 16)

9. Slide one (1) of the supplied 4-inch exhaust clamps over the Banks intermediate pipe.

NOTE: On extended cab long-bed and crew-cab long-bed vehicle, the clamp that is used between the intermediate pipe and muffler is a combination hanger/clamp. When this hanger clamp is installed the hanger pin should be inserted into the factory rubber hanger and the clamp should be rotated until the hanger pin is parallel with the frame-mounted pin before being torqued.

10. Install the muffler onto the end of the intermediate pipe outlet. Be sure that the inlet side of the muffler (see markings on muffler body) is facing toward the front of the vehicle. Orient the muffler such that

the "Banks Monster" logo is facing towards the frame and is level with the ground. Verify that the muffler and intermediate pipe are completely engaged.

11. Slide one (1) of the supplied 4" exhaust clamps onto the Banks Monster muffler outlet.

12. Install the tailpipe into the outlet of the muffler. Be sure that the two pipes are completely engaged. Insert the front and rear tailpipe hanger pins into the factory rubber hangers. Rotate the tailpipe until the hanger pins are parallel with the frame mounted pin.

NOTE: Minimum distance between exhaust tip and body a one (1) inch.

13. Adjust each of the pipes to ensure that all of the hanger pins are parallel with the frame-mounted pins and that the rubber hangers are all positioned slightly forward (See **Figure 1.2**). The amount of forward angle on the rubber hangers should increase the farther downstream the hanger is positioned. This allows the hangers to be properly positioned once the exhaust system reaches operating temperature.

14. Tighten the head pipe V-band clamp to 12 ft-lbs (if previously loosened).

15. Install the exhaust clamp at each of the three (3) joints. **Figure 1.3** illustrates the proper location of an exhaust clamp on a tubing joint. Torque the nuts on each of the exhaust clamps to 35 ft-lb.

NOTE: If a combination hanger/clamp is utilized, evenly torque nuts to 35 ft-lb. The clamps only need to be tight enough to form a seal and hold the pipes together. Over tightening the clamps may cause the system to leak due to the pipe being crimped.

Torque the four (4) factory flange nuts, previously removed, to 30 ft-lbs.

16. Install exhaust tip by sliding it over the outlet of the tailpipe. The tip should be positioned so

is approximately one (1) inch past the outlet of the tailpipe or where aesthetically pleasing.

NOTE: On vehicles with dual rear wheels, the outlet of the tip should be placed approximately 3.5 inches past the outlet of the tailpipe.

Torque the band clamp to 35 ft-lbs. Skip to **Step 36** to complete Banks Monster Exhaust System.

BANKS SPLIT-DUAL MONSTER EXHAUST SYSTEM (Step 24 thru 35)

17. Install a 4" saddle clamp onto the Monster muffler inlet. Install the Monster muffler inlet onto the Banks intermediate pipe outlet. Be sure that the inlet side of the muffler (see markings on muffler body) is facing toward the front of the vehicle. Orient the muffler such that the "Banks Monster" logo is facing towards the frame and is level with the ground. Verify that the muffler and intermediate pipe are completely engaged.

18. Install the muffler hanger clamp onto the muffler outlet. Insert the hanger pin into the vehicle's rubber insulator.

19. Install the Banks Y-pipe into the muffler outlet such that the outlets are pointing up. Install a 3-1/2" saddle clamp onto each Y-pipe outlet (See **Figure 1.4**).

20. Install the driver-side hanger bracket into the rear of the driver-side frame rail. If a hitch is installed, remove the hitch hardware on the driver-side, install the frame bracket and reinstall the existing hitch hardware.

For Long bed models, use one (1) bolt on the flat of frame rail and one (1) bolt on the side of the frame rail.

*For Short bed models, use two (2) bolts on the flat of the frame rail (no bolts on the side). See **Figure 1.5**.*

21. Install the supplied rubber insulator onto the Banks hanger bracket.

22. Install the driver-side tailpipe (longer) into the top Y-pipe outlet. Install the driver-side tailpipe hanger into the Banks rubber insulator.

Figure 1.3

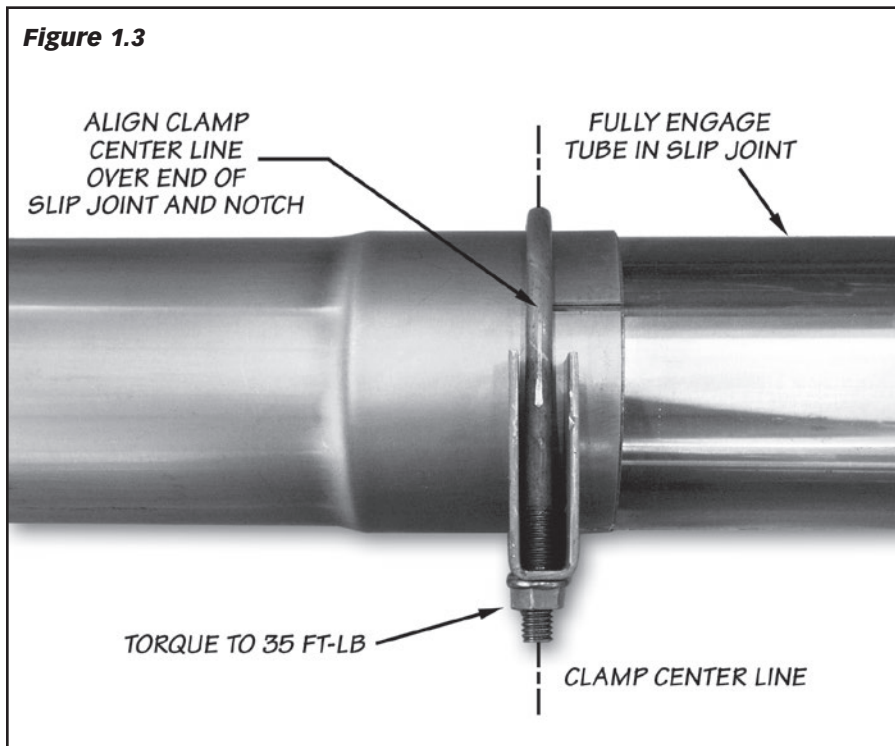
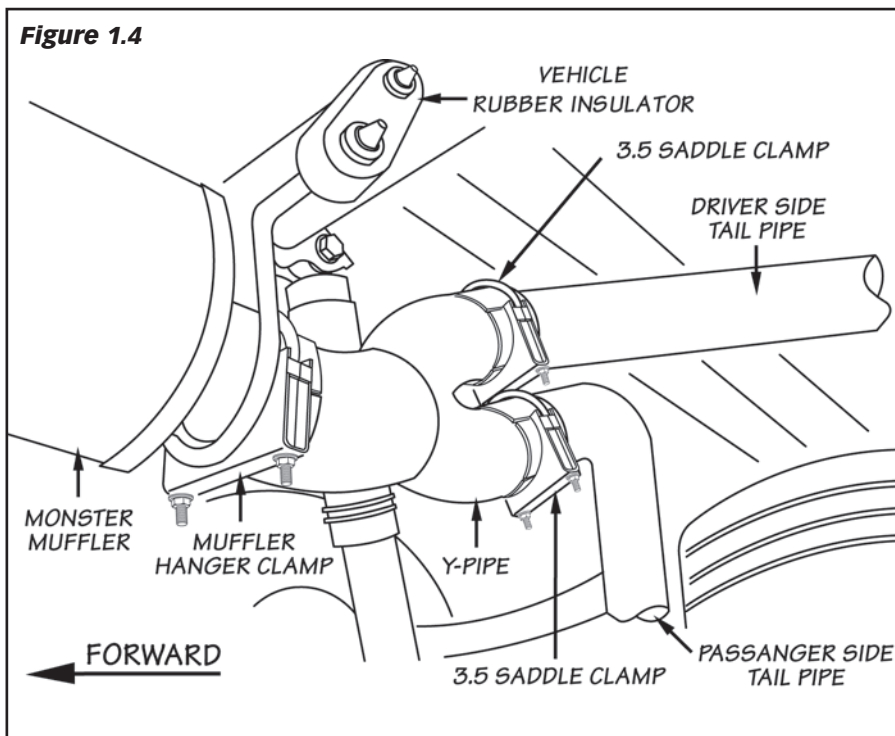

Figure 1.4



23. Install the passenger-side tailpipe (shorter) into the lower Y-pipe outlet. Install the passenger-side tailpipe hanger into the vehicle rubber insulator.

24. Adjust each of the pipes to ensure that all of the hanger pins are parallel with the frame mounted pins and that the rubber hangers are all positioned slightly forward (See **Figure 1.2**). This allows the hangers to be properly positioned once the exhaust system reaches operating temperature.

25. Be sure that the two (2) tailpipes are completely engaged into the Y-pipe. Rotate the tailpipe until the hanger pins are parallel with the frame-mounted pin. Be sure both tailpipe tips look symmetrical.

NOTE: Minimum distance between exhaust tip and body is a half (1/2) inch.

26. Tighten the head pipe V-band clamp to 12 ft-lbs (if previously loosened).

27. Align the saddle clamps on the radius of the corresponding pipe slots. **Figure 1.3** illustrates the proper location of an exhaust clamp on a tubing joint. Torque the nuts on each of the exhaust clamps to 35 ft-lbs. Torque the four (4) factory flange nuts, previously removed, to 30 ft-lbs. Torque the hanger bracket 1/2" hardware to 65 ft-lbs.

28. Using the three (3) supplied wire ties, tie any hoses, brake lines or harnesses a minimum of four inches away from the exhaust/tail pipes.

29. Remove the protective covering from the tailpipe tip.

Caution: the protective covering may ignite and burn if not removed prior to running the engine.

30. The Banks Monster Exhaust installation is now complete.

-END, SECTION 1-

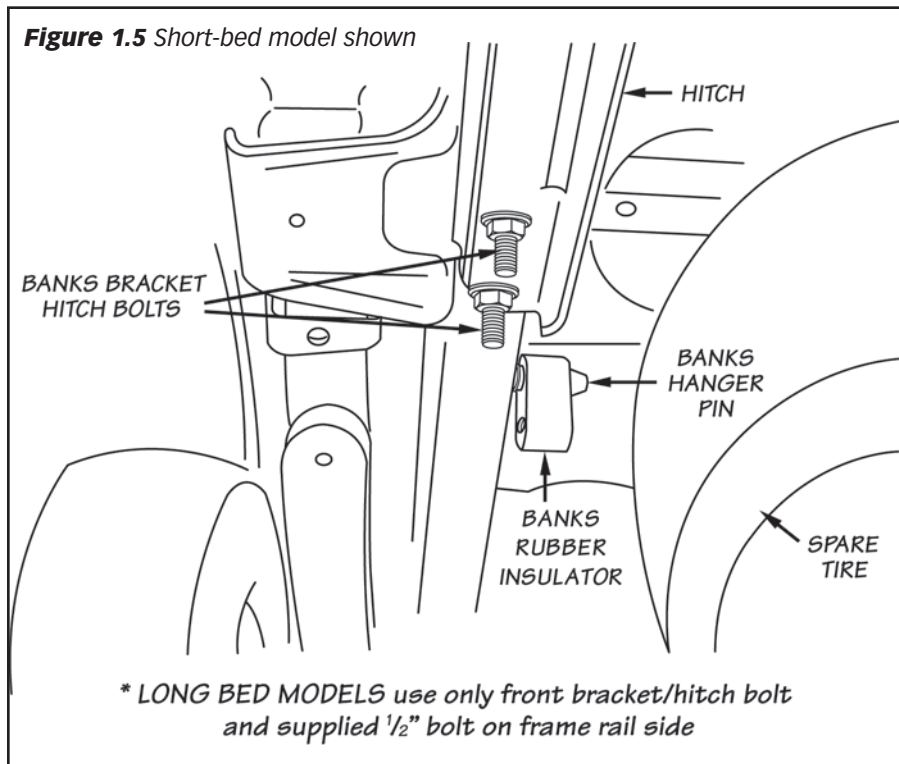

Section 2

TECHNI-COOLER ASSEMBLY INSTALLATION

Figure 2.1



Figure 2.2 Removal of Push-In Retaining Pins

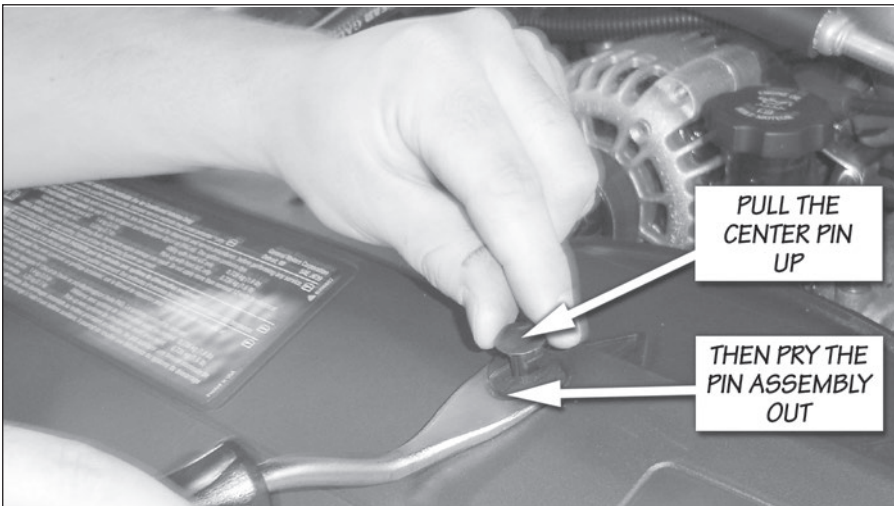
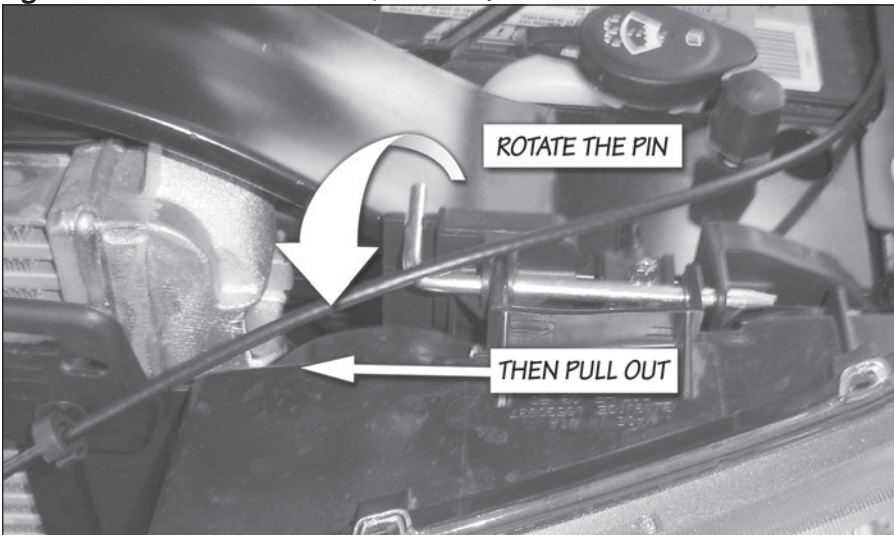

Figure 2.3 2006-07 LBZ: Headlamp Assembly Removal



REMOVE STOCK INTERCOOLER

1. Disconnect the ground cables from both the driver and passenger side batteries. Position the loose cables so that they do not come into contact with their respective battery posts during the installation.

2. Remove air box filter assembly. Loosen the hose clamp from the stock intake tube on the turbo inlet. Separate the stock intake tube connected to the turbo inlet. Remove the Air Flow (MAF) sensor connector from stock air box filter cover. Remove stock air box by lifting the air box up and out. The bottom of the stock air box is held in place by rubber grommets. There may be some slight resistance when removing the stock air box. See **Figure 2.1**.

NOTE: Be careful not to damage the connector or the MAF sensor.

3. Remove the upper grill baffle. Remove the upper grill baffle that mounts between the grill and radiator cross brace. The baffle is held in place by 7 push-in retainers. The retainers are removed by pulling up on the center pin, then prying the retainer out of its hole as shown in **Figure 2.2**.

4. Pull the grill from the vehicle. Remove the grill by disengaging the 6 snaps at the outboard ends of the grill.

5. Remove the inner fenderwell. Remove the 8 pushpin fasteners and 2 large head plastic fasteners that attach both driver's and passenger's side fenderwell.

NOTE: The fasteners are accessed through the wheel arch opening. Pull the fenderwell down approximately 6 inches once the fasteners are removed. Disconnect the wire harness retaining clips on top of the fenderwell, and then remove the fenderwell from the vehicle.

6. Disconnect connectors from headlamp assemblies and remove headlamp assemblies. Rotate the headlamp-retaining pin, then remove the pin as shown in **Figure 2.3**. Disconnect the connectors from the backside of the headlamp assembly, and remove both driver's and passenger headlamp assemblies from the vehicle. Next, remove the

park/turn signal lamp assembly by depressing the outboard retaining clip, then rotating the assembly outward as shown in **Figure 2.4**. Remove the bulbs from the turn signal lamp assembly by turning the lamp sockets a quarter turn counterclockwise.

NOTE: The headlamp is easily disengaged and does not require force to be removed once the outboard clip has been depressed.

Attention: Number and location of bolts on the headlamp assembly may vary by model and year.

NOTE: The inner fenderwell cover must be removed to access the bottom bolt. Next, remove the (3 per side) bolts to the head assembly grill support bracket. Disconnect the connectors from the backside of the headlamp assembly from both driver and passenger headlamp assemblies. Remove the headlamp assemblies.

NOTE: Slide the headlamp assembly toward the center and forward of the vehicle to remove. The turn signals are built into the headlamp assembly.

7. Remove the plastic headlamp mounting structure. Remove the plastic headlamp mounting structure on the driver and passenger side of the vehicle shown in **Figure 2.5**. There are (6x) bolts, (2x) torx head bolts, (1x) push-in retainer and (1x) large clip that must be disconnected to remove the piece from the vehicle, per side. The plastic piece that resides by the bumper must be detached from the headlamp mounting structure, but will remain on the vehicle. The retaining clip that attaches the hood latch cable to the support structure must also be removed on the driver's side.

8. Remove the two bolts that secure the upper fan shroud to the upper radiator cross brace. Remove the four push-in retainers (2 per side) that attach the upper section to the lower section of the fan shroud. These retainers are removed by pulling up on the center pin then prying the entire retainer assembly out as shown in **Figure 2.2**.

9. Carefully remove the transmission module from the upper fan shroud. Lay the module to the side. See **Figure 2.6**.

Figure 2.4 2006-07 LBZ: Parking Lamp Assembly Removal

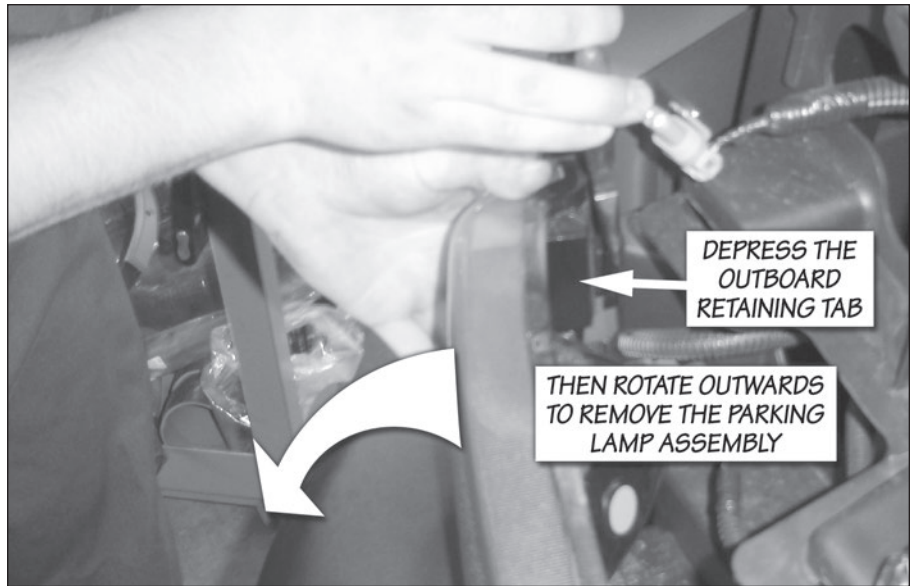

Figure 2.5 '06-07 LBZ: Removal of Headlamp/Parking Lamp Assembly Support Structures.

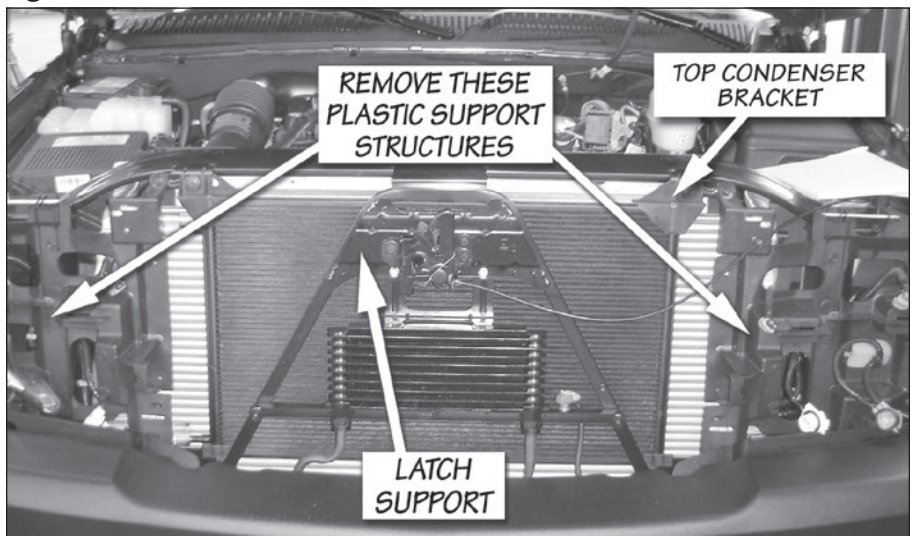

Figure 2.6 Transmission module

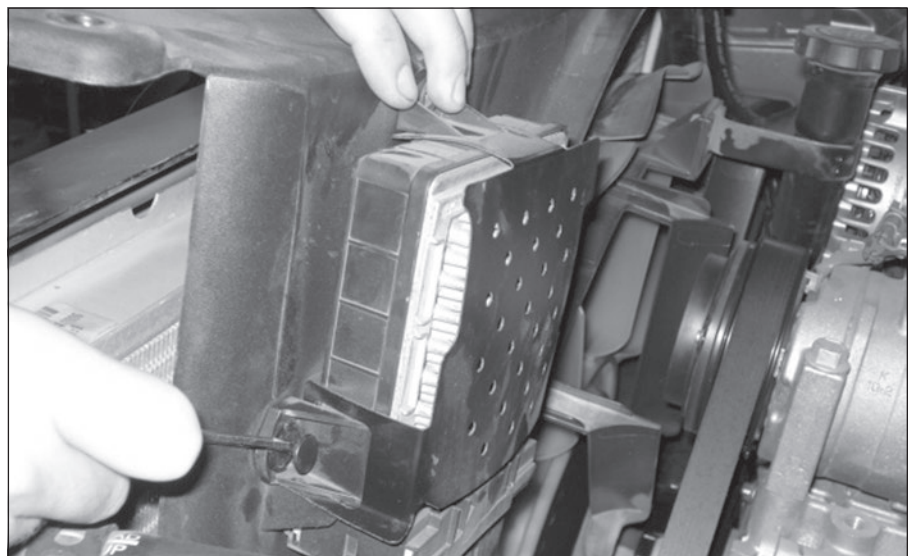

Figure 2.7 Latch Support Moved Out of the Way

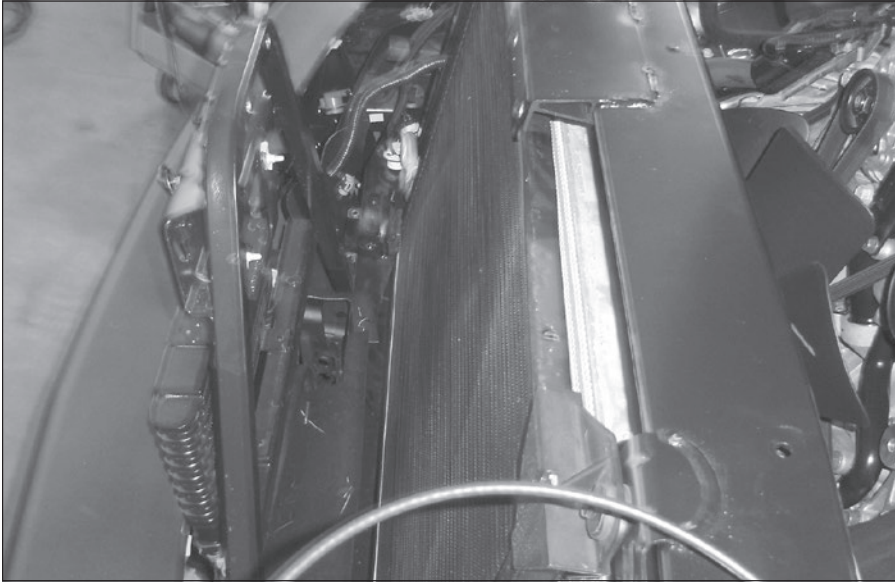

Figure 2.8 Upper Intercooler (CAC) Attachment Bolt.

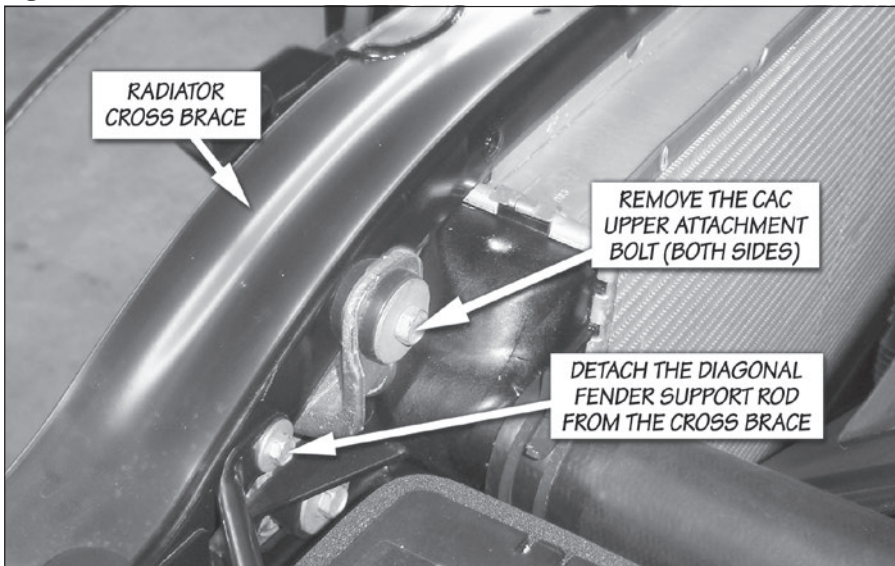
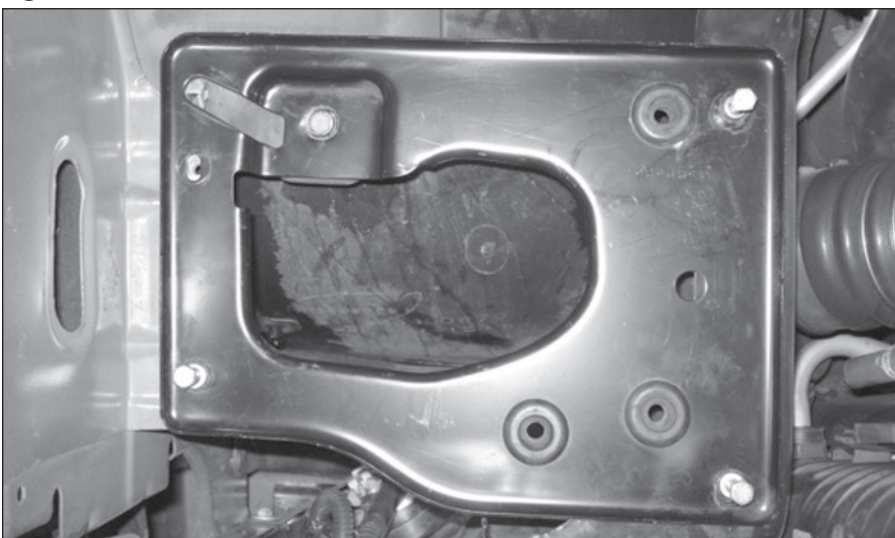

Figure 2.9 Air box tray



10. Remove the low pressure A/C condenser line from the line retainer attached to the upper fan shroud.

11. Remove the upper section of the fan shroud from the vehicle. Take care not to damage the face of the radiator when removing the shroud.

12. Remove the two upper condenser mounting bolts that attach to the radiator cross brace.

13. Mark the location of the hood latch, then remove the hood latch from the latch support. The latch is held in place by three bolts. The latch support is shown in **Figure 2.5**. It is not necessary to remove the cable from the latch, just place the latch and cable assembly out of the way.

14. Remove the two bolts that attach the latch support to the radiator cross brace and the 4 lower attachment bolts (2 per side). The two bolts that attach the upper support to the radiator cross brace are accessed from the engine compartment side of the vehicle.

16. Swing the latch support forward as shown in **Figure 2.7**.

17. Pull the air conditioning condenser out of its lower mounts, and place it against the latch support.

18. Remove the two upper Charge Air Cooler (CAC) mounting bolts and unfasten the fender support rod from the cross brace as shown in **Figure 2.8**.

19. Remove the 6 bolts (3 per side) that secure the radiator cross brace. The cross brace is shown in **Figure 2.8**. The bolts are on the bottom side at each end of the support. Remove the cross brace from the vehicle.

20. Remove the air box-mounting tray from the vehicle shown in **Figure 2.9**.

Figure 2.10 Air box support bracket

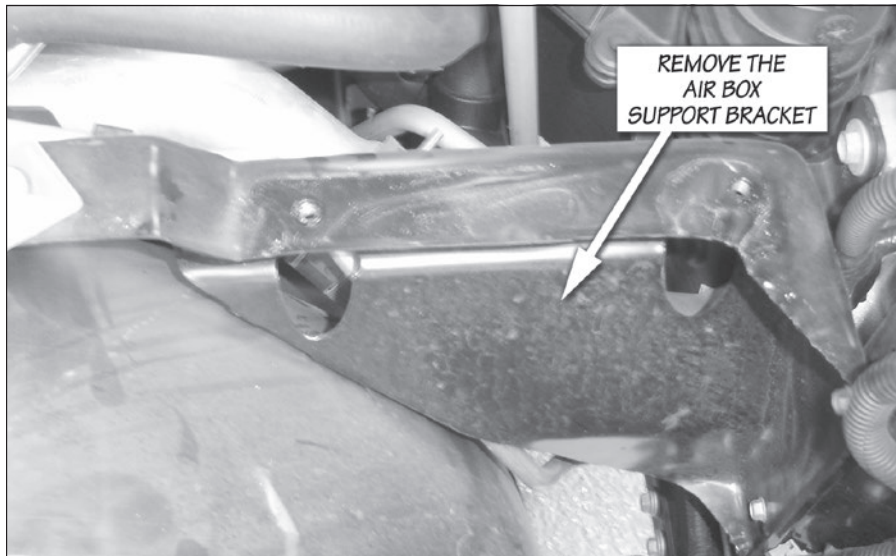

21. Remove the air box support bracket shown in **Figure 2.10**. There is an a/c condenser line retaining clip and a plastic fastener that attaches to the inner fenderwell that must be removed before the bracket can be liberated from the vehicle.

22. Trim the air box support bracket per the template in **Figure 2.12** and **Figure 2.13**. **Figure 2.11** shows the bracket before and after trimming.

NOTE: Paint trimmed edge to protect from rust.

Figure 2.11

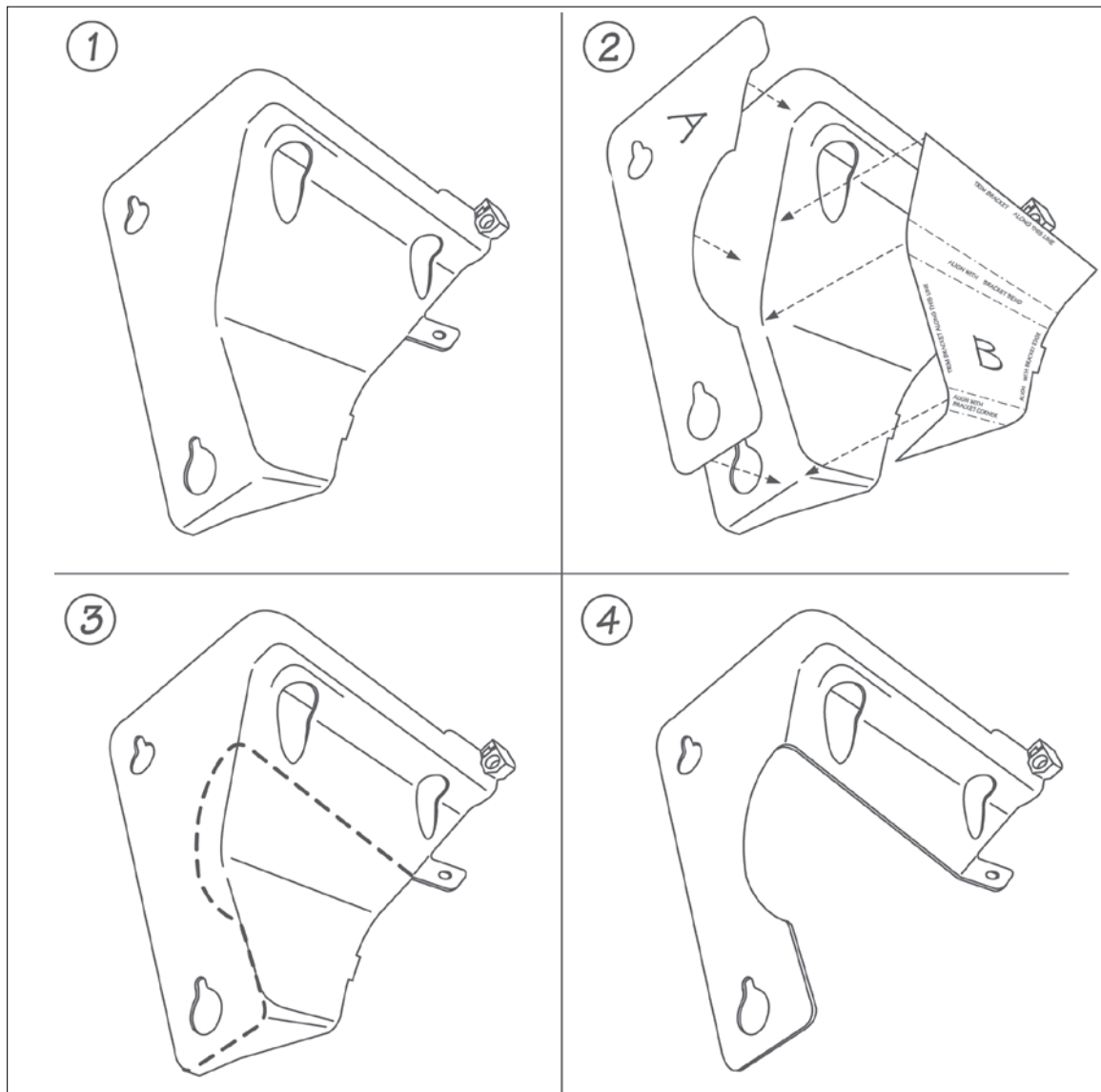

Fig 2.12. Trim template for the air box-mounting bracket.

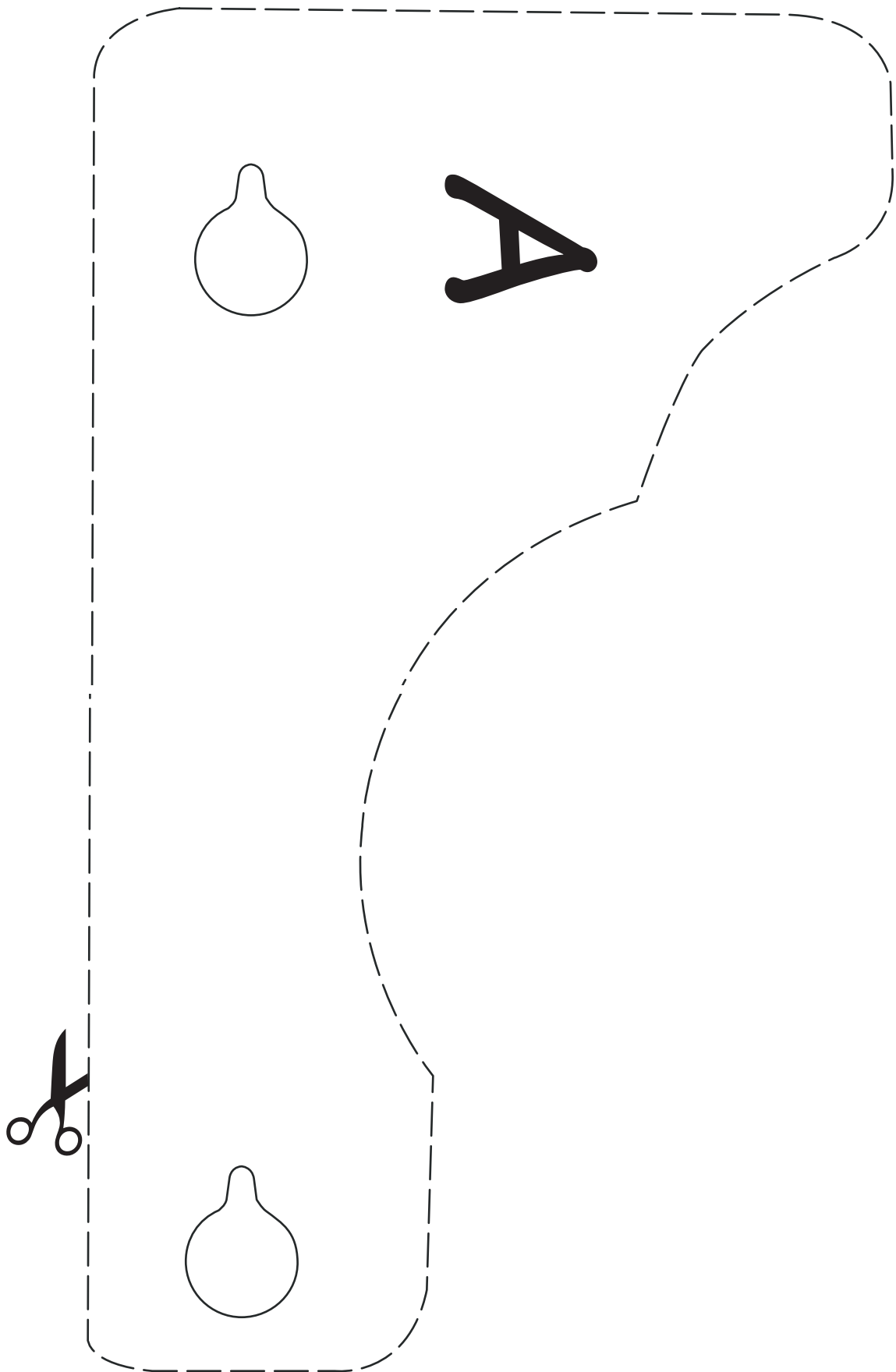

Fig 2.13. Trim template for the air box-mounting bracket.

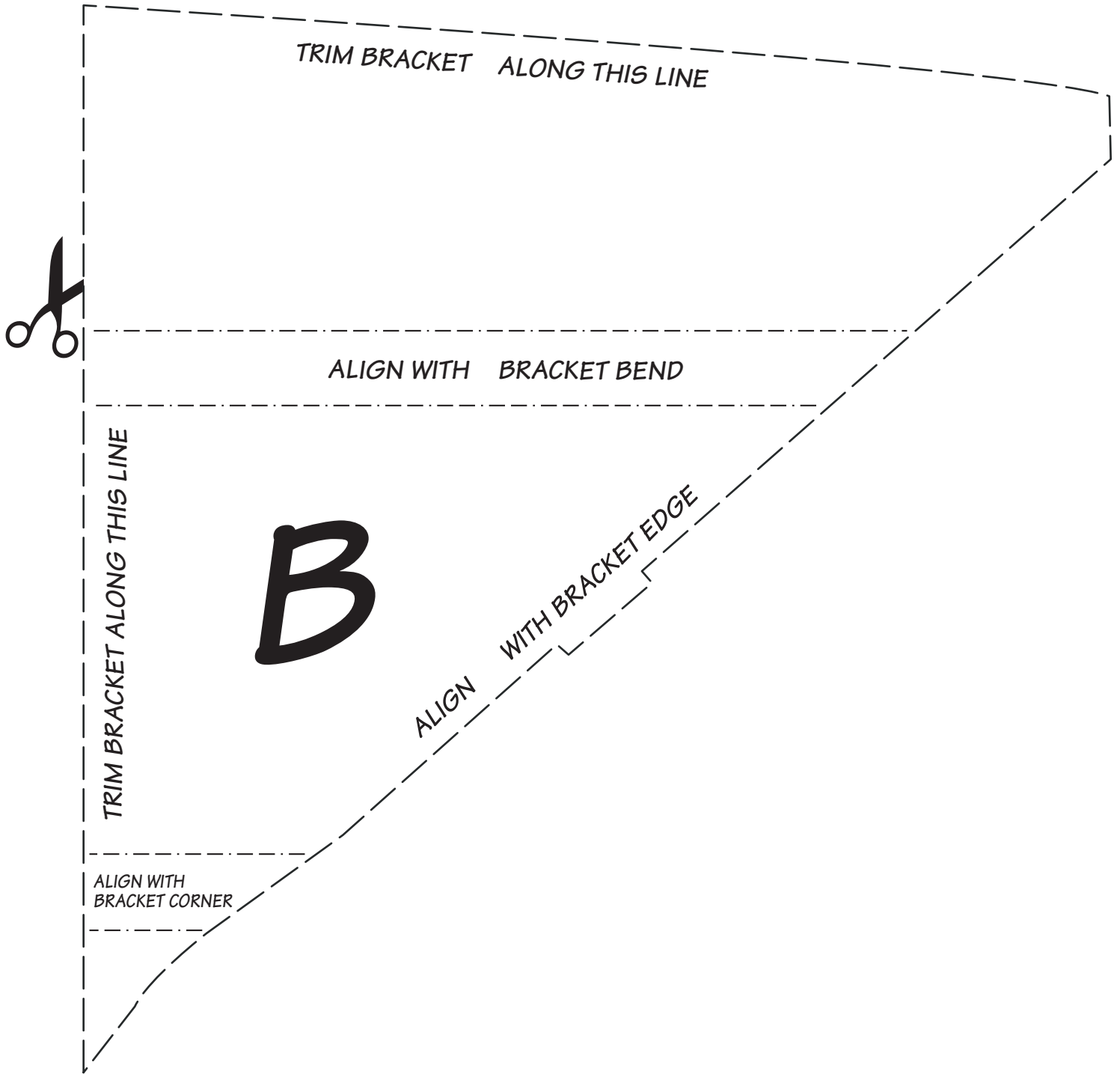

Figure 2.14 Drivers side boost hose

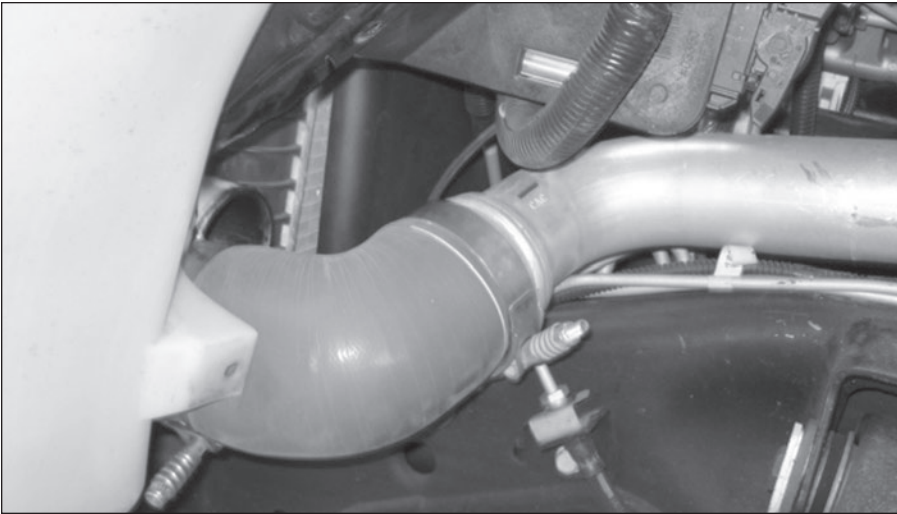

Figure 2.15 Passanger side boost tube

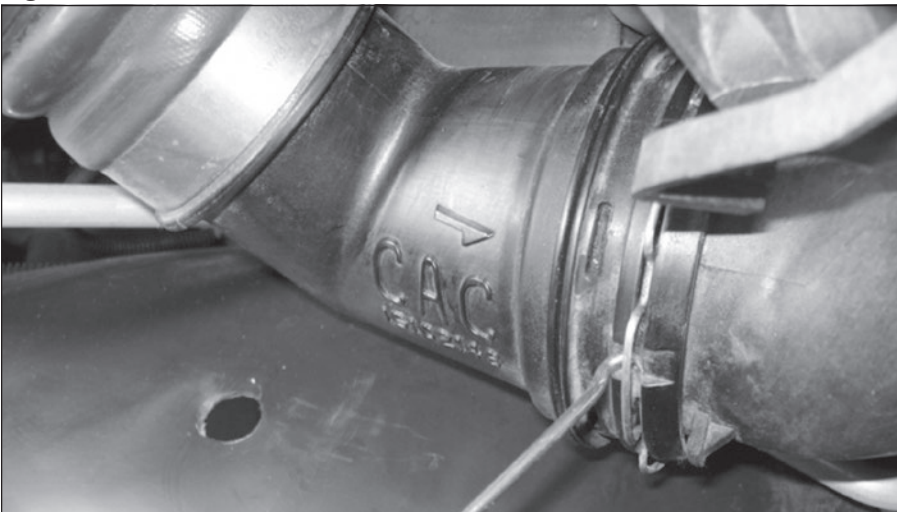

Figure 2.16 Passanger side boost tube



23. Loosen the driver side boost tube hose clamps. Remove the boost tube off the charge air cooler (CAC). Do not damage the hoses that attach to the charge air cooler (CAC) as it will be reused. Cover the hose opening to prevent foreign debris from entering. See **Figure 2.14**.

24. Remove the passenger side boost tube hose. Use a hook or small screwdriver to remove wire-retaining clip. Remove the lower then the upper wire-retaining clip. Use a prying device to detach lower coupling hose connection. Pull off by twisting upper (hose coupler). Cover the intake manifold and turbocharger discharge to prevent foreign debris from entering during the installation. See **Figure 2.15** and **Figure 2.16**.

25. Remove the radiator attachment bolts. There are four 13mm socket.

26. Lift the radiator out of it's lower saddle mounts and position it towards the engine so that it is no longer attached to the charge air cooler. Take care not to damage the radiator cooling fins.

27. Remove the charge air cooler from the vehicle. Check that the lower mounting peg grommets are removed from the stock intercooler and place to the side. The lower rubber grommet will be transferred to the Banks intercooler in the next step.

INSTALL BANKS TECHNI-COOLER

28. Locate the supplied Banks charge air cooler and transfer both top and bottom rubber grommets and corresponding metal sleeve into position on the Banks charge air cooler.

29. Install the Banks CAC into the vehicle. Align the lower CAC mounting pegs with the rubber mounts in the vehicle's frame. There is a significant amount of play in the rubber mounts that can allow them to be aligned with the CAC as required.

30. Reinstall the radiator cross brace. Leave the attachment bolts loose to aid in aligning the CAC with the support.

31. Reinstall the radiator onto CAC. Secure the radiator to the Banks CAC with $\frac{5}{16}$ "-18 by $1\frac{1}{8}$ long bolts and large OD washers supplied in the Banks system. Tighten to 10-12 ft-lbs.

NOTE: Install the top two bolts 1st then install bottom two bolts. It may be helpful to use a pry bar or similar to assist in aligning the screw holes between the radiator and the Banks charge air cooler.

32. Install the upper CAC attachment bolts that were previously removed. There is enough play in the lower mounting pads, that the CAC can be positioned to align with the upper cross brace. Tighten the bolts.

33. Check that the engine-cooling fan can freely spin without contacting the lower fan shroud. If the fan contacts the shroud, the shroud must be realigned with the radiator.

34. Tighten the 6 radiator-cross brace bolts to 80 in-lbs. Install the diagonal fender support brace and tighten the bolts.

35. Install the upper fan shroud. The push-in retainers that secure the upper shroud to the lower shroud are secured by inserting the retainer with the center pin pulled out. Once the retainer is inserted, press the center pin down to secure the retainer. Install and upper fan shroud bolts. The stock upper fan shroud bolts are reused and should be tighten to 80 in-lbs.

36. Install the transmission control module to the upper fan shroud.

37. Install the a/c condenser and tighten it's upper mounting bolts to 80 in-lbs.

38. Install the latch support. Tighten it's six attachment bolts to 80 in-lbs.

39. Install the hood latch. Position it so that it aligns with the marks that were previously made on the latch support prior to it's removal. Tighten it's bolts to 80 in-lbs.

40. Install the driver and passenger side plastic headlamp support structures. Tighten the screws to 80 in-lbs.

41. Install the light bulbs into the park/turn signal lamp assemblies. These are held in place by turning them clockwise. Install the park/turn signal lamp assembly onto the vehicle for both the driver and passenger side.

42. Install the electrical connectors to the headlamp assembly. Install the headlamp assemblies and secure them with their retaining pins.

43. Install the grill by snapping in the tabs into the retainer clips.

44. Install the upper grill baffle and secure with the seven push-in retainers that were previously removed. The push-in retainers that secure the grill baffle are secured by inserting the retainer with the center pin pulled out. Once the retainer is inserted, press the center pin down to secure the retainer.

45. Install the driver and passenger side boost tubes. Tighten the driver side hose clamps to 75 in-lbs. Make sure when reinstalling the passenger side boost tube that the hose coupler fits tight and flush to its respective mounting location, then reinstall the wire retaining clip.

NOTE: Before slipping any boost tubes and the corresponding hoses, into position, ensure that all connection ends are clean and free of any oil residue and contaminates. Clean compressor outlet and all connection points with a non-oil based solvent such as Acetone, Mineral Spirits, Denatured Alcohol or Lacquer Thinner. Read and follow the manufactures operation instruction for non-oil based solvent cleaner.

NOTE: The a/c line that runs near the intake manifold will need to be bent downward to provide clearance for the boost tube. The a/c line can be bent by placing a wooden block on the a/c line, then lightly tapping the block with a hammer.

46. Install the driver side and passenger side fenderwell. The charge air temperature before the CAC approaches 400°F at full load. So, take care to route wiring away from the driver side boost tube and re-install the factory wire retainers on the fenderwell cover.

47. Install the lower air cleaner support bracket. Tighten the bolts to 80 in-lbs. Install the air cleaner mounting tray. Tighten the bolts to 80-in-lbs.

48. Install the air box assembly on it's mounting tray. Install the air duct on the turbocharger inlet and tighten it's hose clamp.

49. Re-install the connector on the MAF sensor at the air box assembly

50. Re-connect the ground cables on both batteries

-END, SECTION 2-

Section 3

THERMOCOUPLE INSTALLATION

1. The thermocouple monitors the temperature of the exhaust gases entering the turbocharger at the turbine housing. Installation requires that the exhaust manifold be drilled near the manifold outlet. It is recommended that the manifold be removed from the engine to thoroughly clean out all metal chips from drilling. If manifold is not removed from the vehicle, all chips must be removed from the manifold. This may be accomplished by using a magnet to extract the chips after drilling. The tap should be greased before use and the chips again removed with a magnet. All metal shavings must be cleaned from the manifold to avoid turbine damage.

2. To access the exhaust manifold remove front passenger wheel well by removal of plastic retainers.

3. On the passenger side, remove the hardware retaining the turbine inlet exhaust pipe to the exhaust manifold using a 12mm, 12pt socket along with a 12mm, 12pt wrench, then remove the exhaust manifold from vehicle. Pay special attention to the orientation of the manifold outlet gasket. Retain the hardware and gaskets for re-assembly.

4. Center punch and drill through the passenger side exhaust manifold into the rear passage at the location shown **Figure 3.1**. Use a $\frac{7}{16}$ " drill, keeping the drill perpendicular to the manifold surface.

5. Tap the drilled hole with a $\frac{1}{4}$ " NPT pipe tap. Check the thread depth as you tap by periodically removing the tap and screwing the thermocouple insert into the tapped hole.

6. Install the thermocouple insert into the manifold using anti-seize compound on the threads. Install the probe in the thermocouple insert.

7. Make sure to remove all shavings from inside the exhaust manifold. Reinstall the exhaust manifold. Torque to 28 ft-lb in the sequence shown see **Figure 3.1**.

8. Attach the thermocouple to the supplied thermocouple leadwire extension with the supplied nuts and bolts. Cover this joint with the supplied heat shrink tubing and heat until the tubing conforms to the joint. Make sure the entire joint is insulated.

9. Route the thermocouple leadwire extension along the factory harness to the driver's side.

*NOTE: The thermocouple will be connected to the EconoMind harness in **Section 5, Step 8**.*

-END, SECTION 3-

Figure 3.1

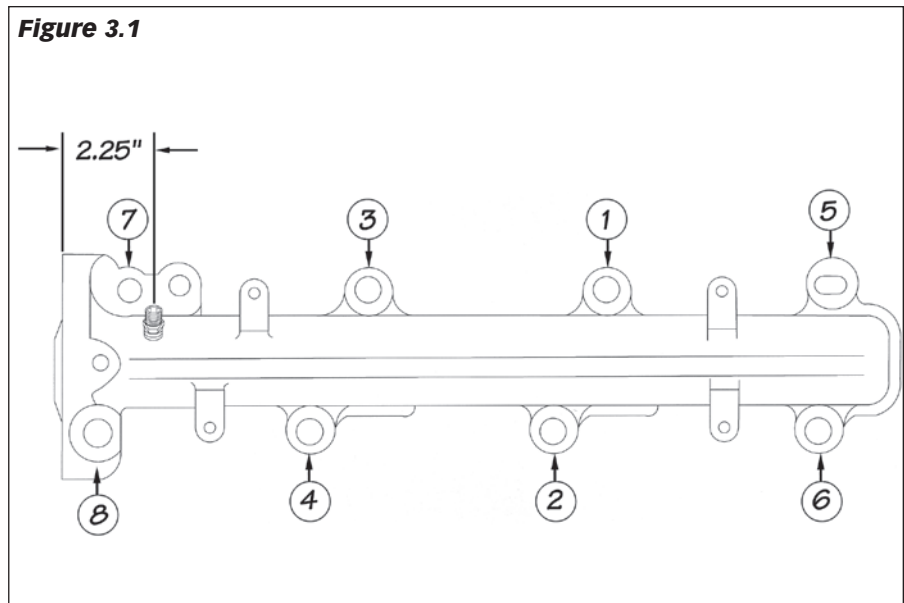

Section 4

BANKS RAM-AIR INTAKE SYSTEM

Figure 4.0
General Assembly
Banks Ram-Air Intake System

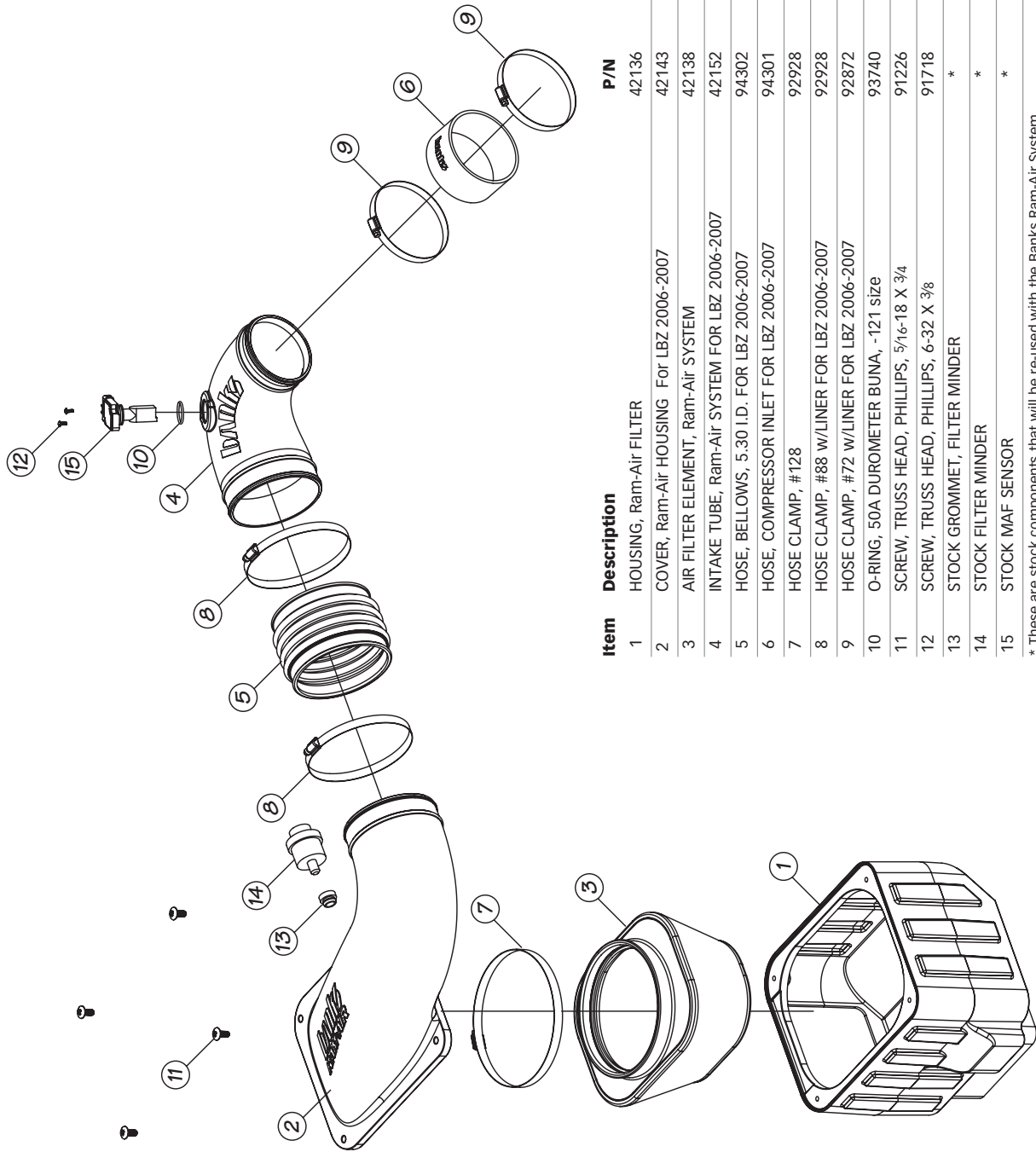

Item	Description	P/N	Qty
1	HOUSING, Ram-Air FILTER	42136	1
2	COVER, Ram-Air HOUSING For LBZ 2006-2007	42143	1
3	AIR FILTER ELEMENT, Ram-Air SYSTEM	42138	1
4	INTAKE TUBE, Ram-Air SYSTEM FOR LBZ 2006-2007	42152	1
5	HOSE, BELLOWS, 5.30 I.D. FOR LBZ 2006-2007	94302	1
6	HOSE, COMPRESSOR INLET FOR LBZ 2006-2007	94301	1
7	HOSE CLAMP, #128	92928	1
8	HOSE CLAMP, #88 w/LINER FOR LBZ 2006-2007	92928	2
9	HOSE CLAMP, #72 w/LINER FOR LBZ 2006-2007	92872	2
10	O-RING, 50A DUROMETER BUNA, -121 size	93740	1
11	SCREW, TRUSS HEAD, PHILLIPS, 5/16-18 X 3/4	91226	4
12	SCREW, TRUSS HEAD, PHILLIPS, 6-32 X 3/8	91718	2
13	STOCK GROMMET, FILTER MINDER	*	
14	STOCK FILTER MINDER	*	
15	STOCK MAF SENSOR	*	

* These are stock components that will be re-used with the Banks Ram-Air System.

Figure 4.1

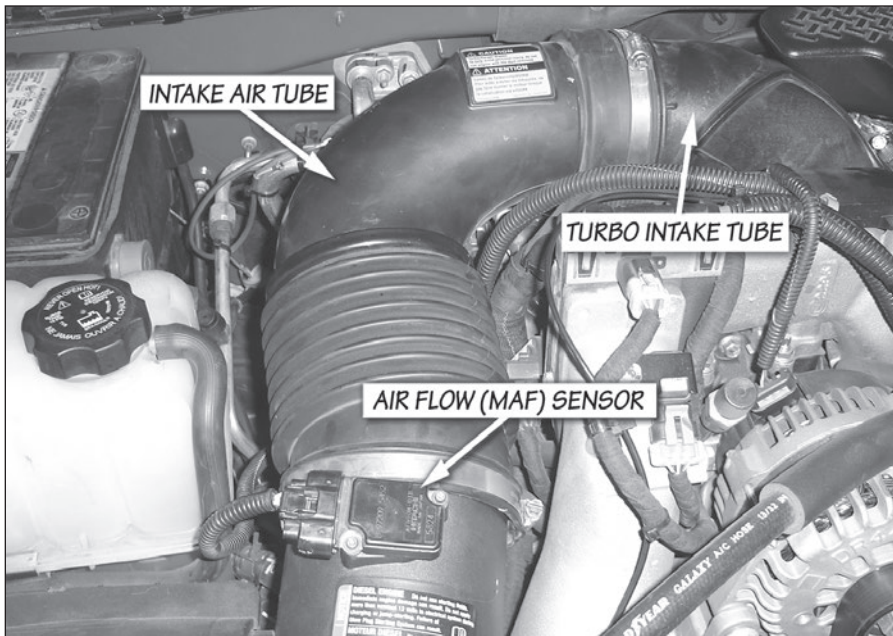

You are about to install the Banks Ram-Air Intake System. Read and follow all steps before working on the vehicle. Some components from the stock air intake system will remain in service. Take care when removing stock air intake components to not damage them.

Use the Bill of Materials Chart and the General Assembly Drawing to reference component nomenclature and location. Use caution when working in the engine compartment. Make sure the engine has been OFF for several hours and cool.

- 1.** Loosen the hose clamp that holds the stock intake air tube to the turbo intake tube.
- 2.** Loosen and separate the stock hose clamp on the intake tube that is connected to the stock air box cover. See **Figure 4.1**.

- 3.** Separate the stock intake tube connected to the turbo intake. Remove the stock intake tube from the engine and set aside.

- 4.** Remove the Air Flow (MAF) sensor connector from stock air box filter cover.

NOTE: Be careful not to damage the connector or the MAF sensor during this process.

- 5.** Remove stock air box by lifting the air box up and out. The bottom of the stock air box is held in place by rubber grommets. There may be some slight resistance when removing the stock air box.

- 6.** Next, remove the stock air box bolts accessible from the top of the engine compartment as shown. Then remove the stock air box tray. See **Figure 4.2**. Keep the previously removed bolts for reassembly later in the installation process.

- 7.** Locate your Banks Ram-Air filter housing from your kit. Align the Banks Ram-Air filter housing to fit parallel to fender edge. Install and tighten the previously removed bolts to secure the Banks Ram-Air filter housing.

*NOTE: The cutout on Banks Ram-Air filter housing must face passenger side fender. See **Figure 4.3**.*

- 8.** Locate your Banks Torx tool, T20H in your Banks Ram-Air kit. Use the Torx tool bit to remove the two (2) screws securing the MAF sensor to the stock air box cover.

Figure 4.2

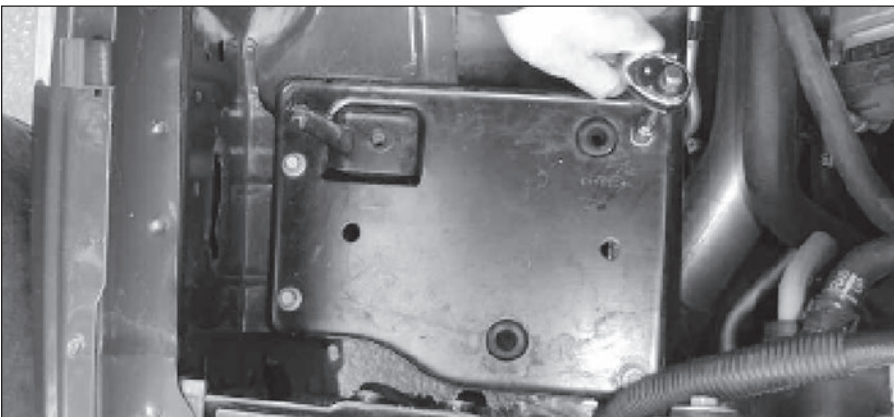
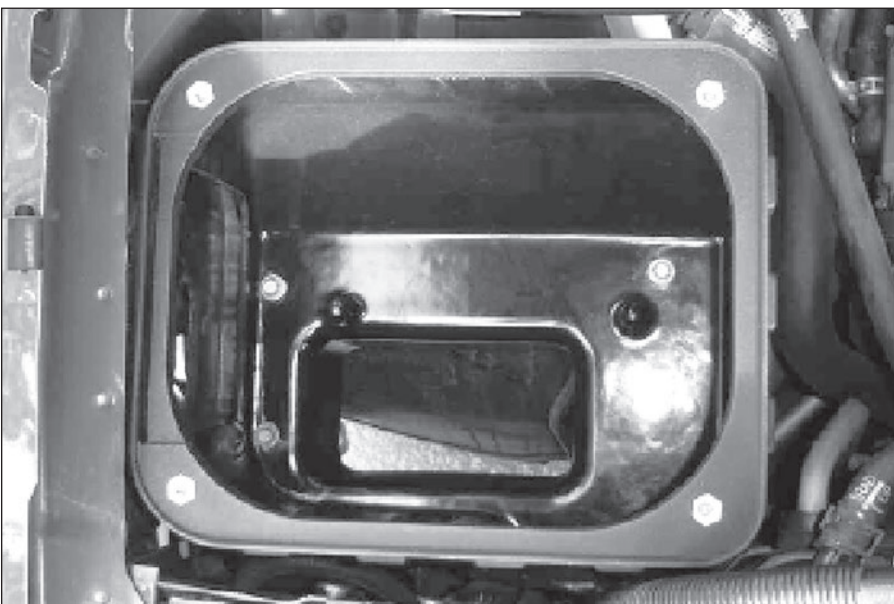

Figure 4.3



NOTE: Be careful when removing the MAF Sensor. When removing the MAF sensor, grasp its body and pull up and out. Do not twist or bend when removing.

9. Install the supplied Banks MAF sensor o-ring onto the MAF sensor. Ensure o-ring is mounted flush to MAF sensor edge as shown (**Figure 4.4**).

NOTE: Retain the stock o-ring. The Banks o-ring will be slid over the stock o-ring on the MAF sensor.

10. Locate your Banks Ram-Air intake tube in your kit. Install the stock MAF sensor (with the additional Banks gasket) to MAF sensor mounting boss as shown. Tighten the screws (included) to 3 in/lbs. See **Figure 4.5**.

NOTE: Ensure correct alignment as shown otherwise screw holes will not align with screw holes in the Banks Ram-Air intake tube.

Caution: DO NOT OVER TIGHTEN SCREWS

11. Locate the previously removed stock air box and remove the stock air filter Minder. Make sure to remove the stock air filter Minder rubber grommet as well. See **Figure 4.6**.

12. Locate the Banks Ram-Air filter housing cover. Install the air filter Minder's rubber grommet into the Banks Ram-Air filter housing cover. Once the rubber grommet is installed flush into the Banks Ram-Air cover, then the filter Minder can be inserted into the rubber grommet. Make sure the air filter Minder is installed flush to rubber grommet.

13. Locate the Banks Ram-Air filter element and the Banks air filter hose clamp. Loosely fit the filter clamp to the air filter element.

*NOTE: See **Figure 4.7** to reference the correct alignment locator groove to the Banks Ram-Air filter.*

Figure 4.4

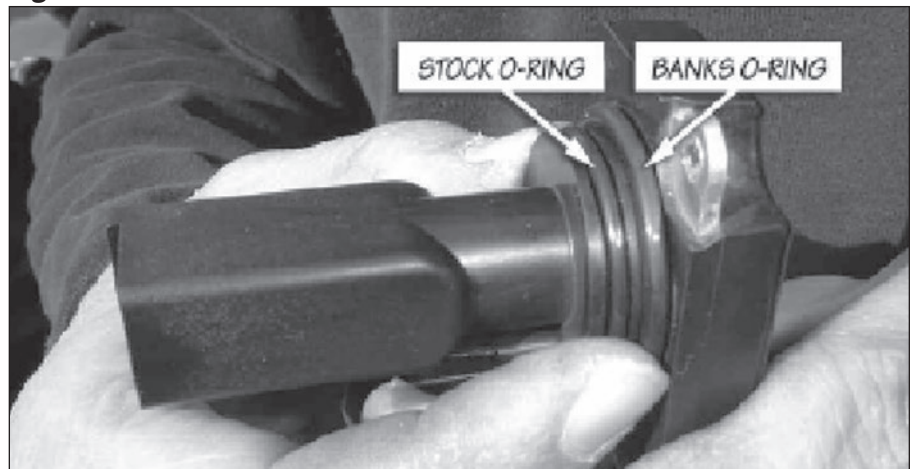

Figure 4.5

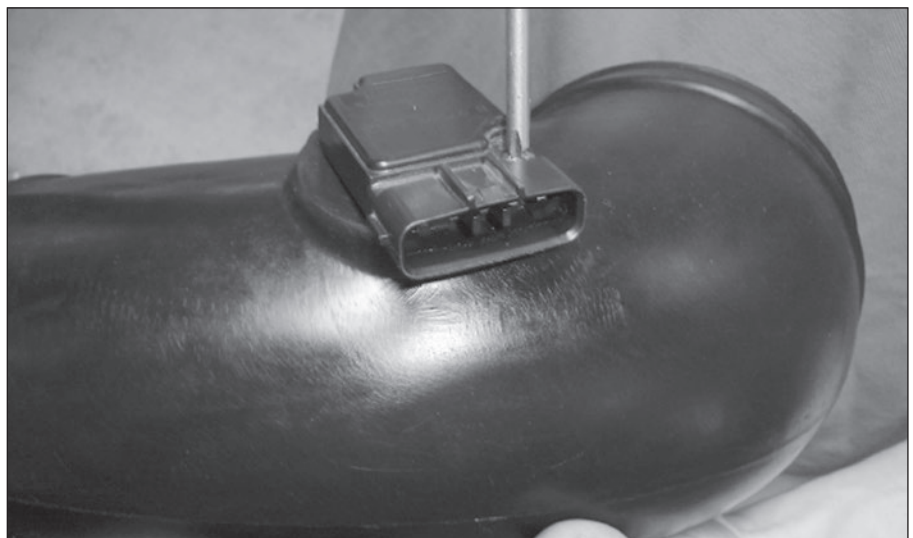

Figure 4.6



Figure 4.7

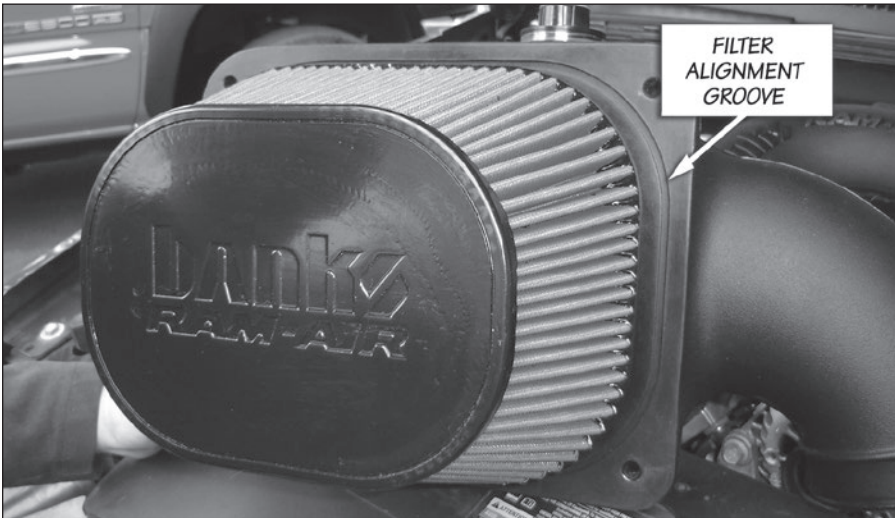
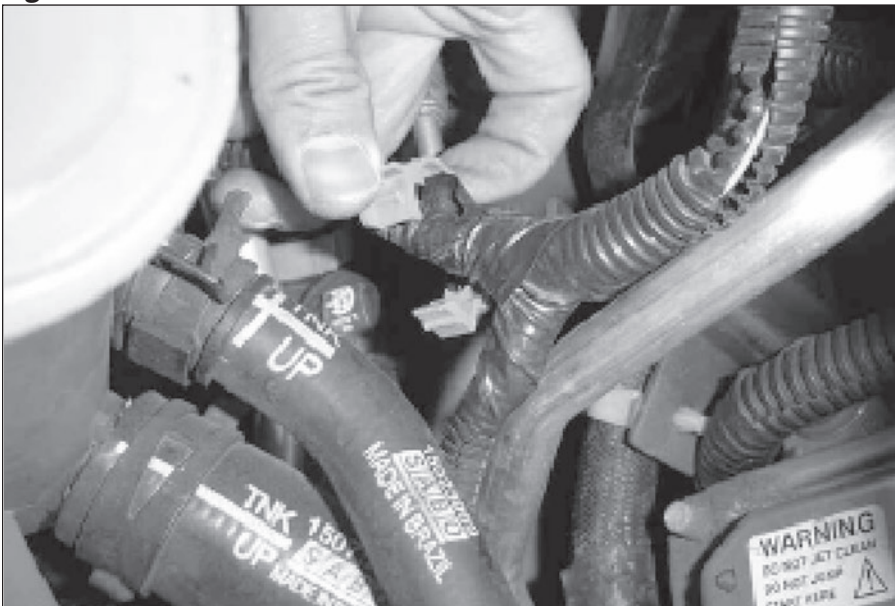

Figure 4.8



Figure 4.9



14. After verifying the alignment between the Banks Ram-Air filter and the Banks Ram-Air cover, press fit the two pieces together until an audible snap is heard. This process will ensure that a correct seal has been established.

15. Tighten the Banks Ram-Air filter hose clamp to the Banks Ram-Air filter cover.

16. Place the Banks Ram-Air filter cover onto the Banks Ram-Air housing. Align and loosely fit the cover onto the housing.

17. Install, but do not tighten, the Banks bellows hose and hose clamp onto the Banks Ram-Air housing cover.

18. Locate the Banks turbo intake hose, tube, and hose clamps from your Banks Ram-Air kit. Loosely assemble the Banks intake hose to the Banks intake tube with the supplied hose clamps. Attach the turbo intake hose to the turbo intake tube. Leave the hose clamps loose.

19. Install the Banks Ram-Air intake tube into the Banks bellows. Tighten all the hose clamps to secure the Banks intake tube. See **Figure 4.8**.

CAUTION: Ensure Intake tube is not touching any engine components.

20. Fasten the Banks air filter cover to the Banks air filter housing using the Banks cover screws and tighten.

21. Re-attach the MAF sensor connector to the MAF sensor in the Banks intake tube.

NOTE: You may have to loosen the wire harness clips to increase the slack in the wiring harness to allow the MAF connector to reach the MAF sensor in the Banks intake air tube (Figure 4.9).

22. Re-connect battery grounds. You have successfully completed the installation of the Banks Ram-Air Intake system. See **Figure 4.10**. Make sure to check all hose clamps for tightness and connectors for a sure fit. Make sure that the intake tube is not touching any engine components.

-END, SECTION 4-

Figure 4.10

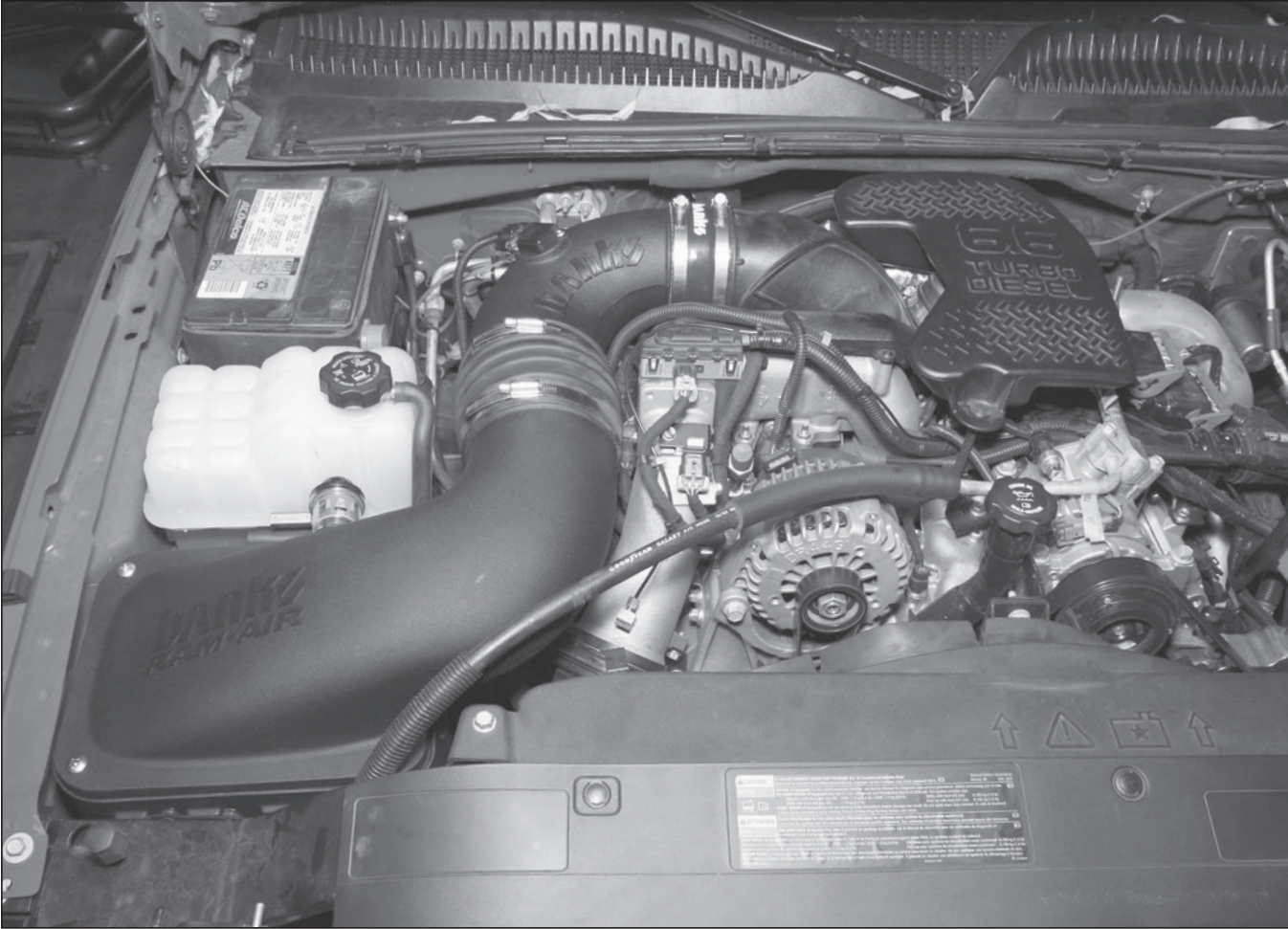

Section 5

BANKS ECONOMIND DIESEL TUNER INSTALLATION

Figure 5.0
General Assembly
Banks EconoMind Diesel Tuner

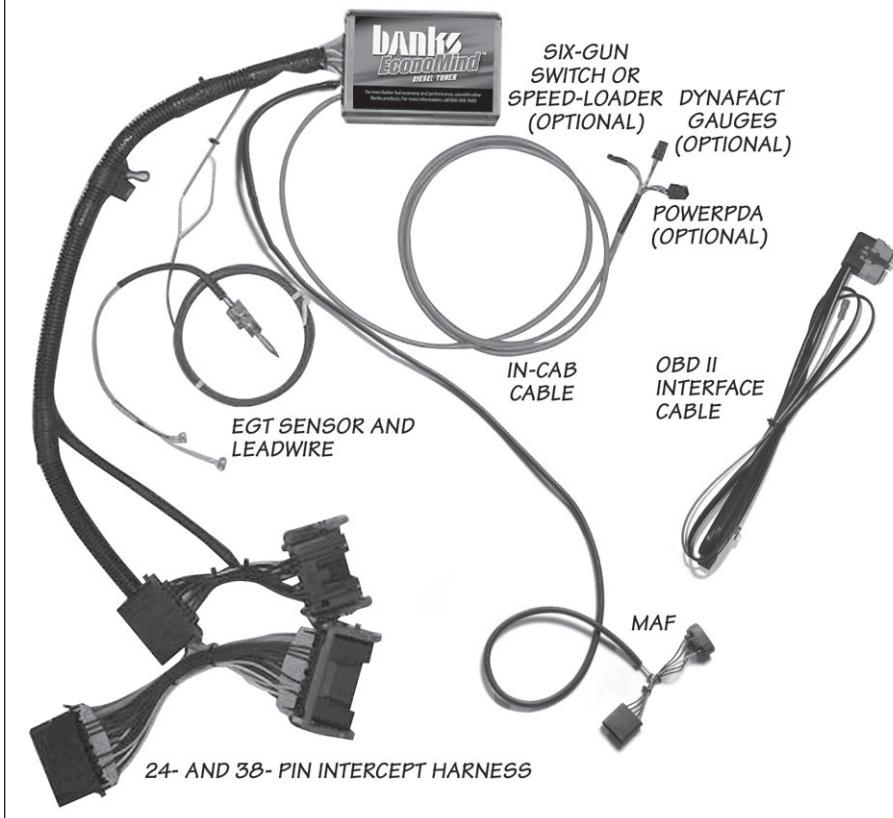

INSTALLATION OF WIRING HARNESS, CONNECTIONS AND EconoMind DIESEL TUNER

1. From the engine compartment, locate the rubber grommet high on the driver's side of the vehicle firewall. The grommet is about 3" in diameter. Make a 1" x 1" cross-shaped incision in the grommet (see **Figure 5.1**).

2. From the engine compartment, feed the grey three-connector cable through the incision made in the firewall grommet and into the cab. From inside the cab, remove the lower dash panel under the steering column to allow access to these three connectors.

3. Locate the two black wire harness locking connectors between the brake fluid reservoir and the air conditioning compressor. Lift the gray connector locks and disconnect the 38-pin connector pair and the 24-pin connector pair (see **Figure 5.2**).

4. Insert the male 38-pin connector on the EconoMind harness into the female 38-pin connector on the factory harness. Insert the female 38-pin connector on the EconoMind harness onto the male 38-pin connector of the factory harness. Repeat this process with the 24-pin connectors (see **Figure 5.2**).

5. Go to the air box and remove the stock Mass Air Flow (MAF) connector located on the Banks Intake tube

6. Locate the MAF connector from the EconoMind harness and route as shown in **Figure 5.3**. Follow the factory harness located on top of the engine that runs in front of the intake manifold and behind the alternator. Feed the connector under the compressor outlet and under where the air intake hose normally rests.

7. Connect the EconoMind (female) MAF connector to the factory (male) MAF sensor and connect the factory (female) MAF connector to the EconoMind (male) MAF connector.

8. Connect the thermocouple leadwire to the EconoMind harness with the supplied nuts and bolts. Cover this joint with the supplied heat shrink tubing and heat until the tubing conforms to the joint. Make sure the entire joint is insulated.

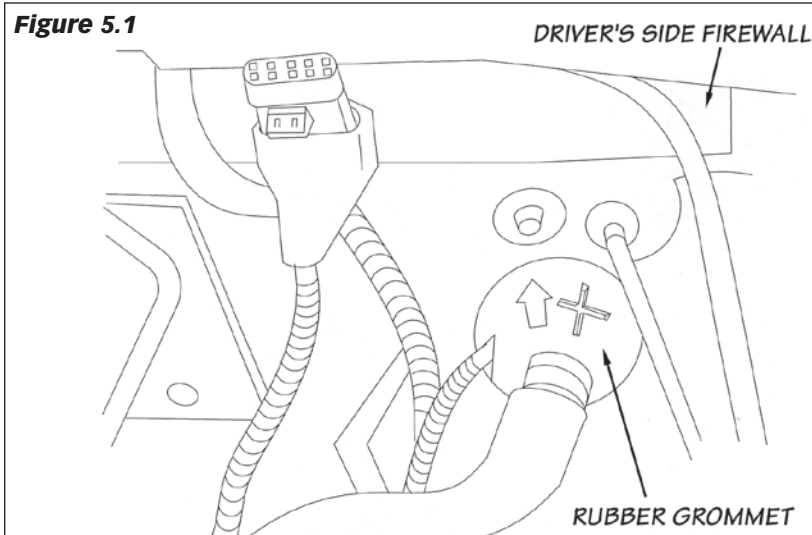

MOUNTING THE BANKS ECONOMIND DIESEL TUNER

9. The EconoMind is to be installed under the hood on the outside of the fuse box, with the wire harness facing towards the rear of the vehicle (see **Figure 5.4**). Make sure the outside of the fuse box is free of oil, grease and dirt.

10. With the Banks EconoMind Diesel Tuner positioned next to the fuse box, peel the protective backing from the hook and loop interlocking fasteners attached to the Banks EconoMind Diesel Tuner. Position the bottom edge of the Banks EconoMind Diesel Tuner approximately a half inch above the main wiring harness exiting the fuse box, then press the adhesive onto the outside of the fuse box. Apply light pressure to the Banks EconoMind Diesel Tuner by hand for 60- seconds to create a strong bond between the fuse box and hook & loop interlocking fasteners. Using the supplied cable ties, secure the wire harness away from any heat sources or moving components.

-END, SECTION 5-

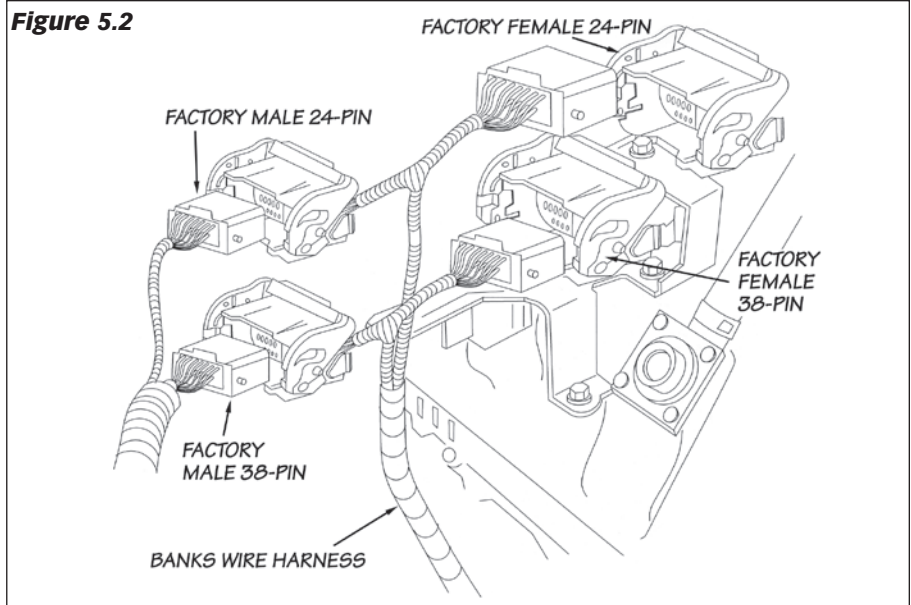

Figure 5.2

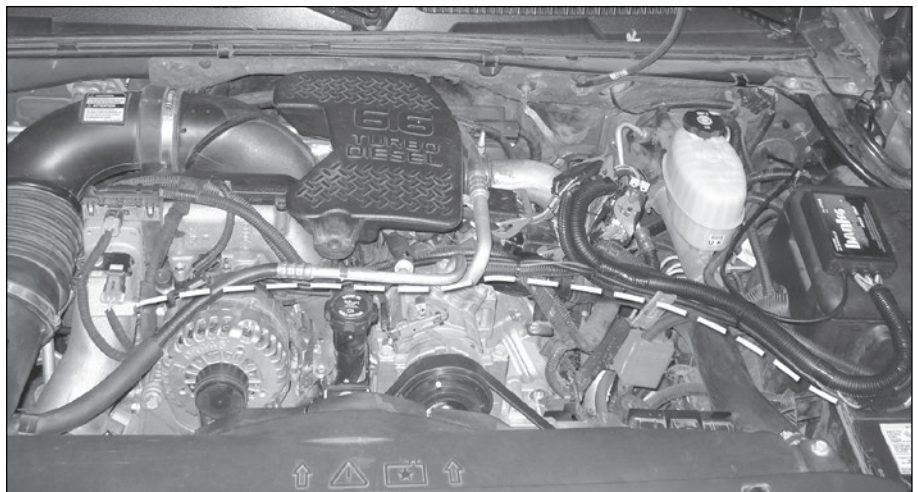

Figure 5.3 Driver's side of engine compartment

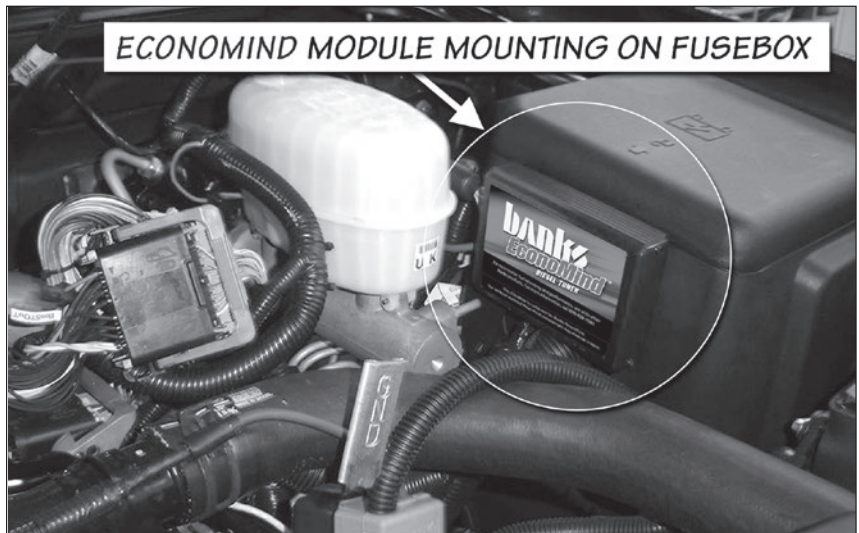

Figure 5.4 ECONOMIND MODULE MOUNTING ON FUSEBOX

Section 6

MOUNTING AND CONNECTING THE BANKS IQ

Section 6 not needed if installing the Power Level Selector Switch. If this is the case, please proceed to Section 7.

WARNING: Below 32° F (0°C) or above 140° F (60°C), the Banks iQ may be susceptible to damage as a result of extended direct exposure to sunlight, heat, or extreme cold. It is highly

recommended that the Banks iQ be removed from its mounting location if the vehicle will be subjected to these conditions for an extended period of time. Gale Banks Engineering is not responsible for damage to Banks iQ resulting from exposure conditions.

CAUTION: Do not use force when working on plastic parts. Permanent damage to the part might result.

1. Locate the Window Mount Assembly in your kit.
2. Assemble the Banks iQ docking station to the Universal mount by inserting and sliding the Universal mount tab into the docking station groove. Hand tighten the nut behind the docking station to hold the docking station in place.

3. Attach the window mount to your Banks iQ. See **Figure 6.1**. Align and place the two (2) lower tabs on the window mount to the corresponding slots on the bottom of Banks iQ first then snap the top of Banks iQ into place.

NOTE: There may be a snug fit when installing the Banks iQ into the window mount. Take care not to force this process.

4. Find a suitable place on the windshield for ease of access and viewing of Banks iQ. Use location shown in **Figure 6.2** as a reference for mounting Banks iQ in your vehicle. Loosen the knob and move the swivel suction plate to achieve desired viewing angle of the Banks iQ screen. Do a test fit and note the angle necessary to achieve the correct viewing angle.

5. Make sure the suction cup and the mounting area on the windshield are clean and dry. With the suction lever in the up position, ensure the suction cup is flat against the windshield, and then push the suction lever down to secure in place.

6. Next, remove and set the fuse access panel aside. See **Figure 6.2**.

7. Locate the Banks OBD II Interface Cable in your kit. This cable has three connection points. Connect the RED OBD II connector on the Banks interface cable to the vehicle OBD II connector. Use a cable tie as shown in **Figure 6.3** to secure the Banks interface cable to the vehicle OBD II connector. Next, connect the 6-pin connector on the Banks OBD II interface cable to the 6-pin connector on the EconoMind Tuner harness.

Figure 6.1 Attaching Banks iQ to window mount

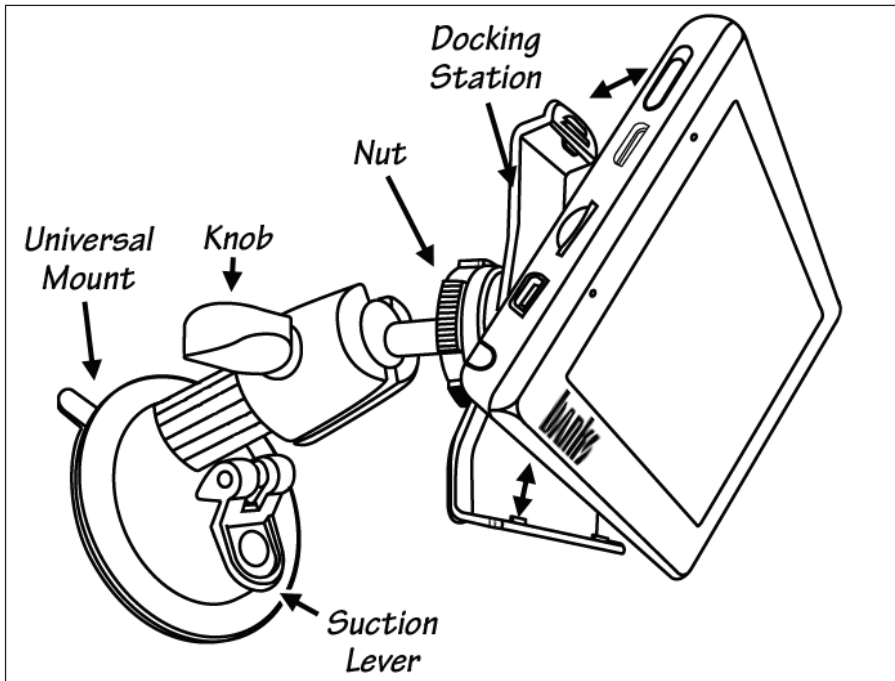

Figure 6.2 Mounting location for Banks iQ, Chevy LMM Shown.



8. Locate the RJ12 Cable (similar to telephone connector) on your Banks OBDII interface cable. See **Figure 6.4**.

9. Locate Banks iQ Bridge Module and connect the RJ12 connector into the Bridge Module. See **Figure 6.5**.

10. Route the Banks iQ USB interface cable from the Banks iQ Bridge Module under the dash and out through the fuse access panel opening. The cable can be slid under the door frame's seal and run up to the top of the dash. Pull enough cable to reach the Banks iQ and connect it to the USB receptacle on the left side of Banks iQ. See **Figure 6.2**. Snap the fuse access panel back in place making sure not to pinch the wire.

WARNING: THE CHARGING CABLE CONNECTED TO THE BANKS iQ IS DESIGNED TO SUPPLY A CONSTANT LOW-VOLTAGE POWER SOURCE (+5VDC) TO THE BANKS iQ AND IS "LIVE" AS LONG AS THE SYSTEM'S OBD II INTERFACE CABLE OR BANKS WIRING HARNESS IS COMPLETELY INSTALLED AND THE USB CABLE CONNECTOR IS PLUGGED INTO BANKS iQ. ALTHOUGH THIS CHARGING CABLE IS SHORT AND ITS CIRCUITRY IS FUSE-PROTECTED, THE USER IS EXPECTED TO TAKE APPROPRIATE MEASURES TO PREVENT SMALL CHILDREN AND/OR PETS FROM CONTACT WITH ANY PART OF THIS SYSTEM.

11. Secure Banks iQ Bridge Module under the dash to any dash frame support using the supplied cable ties. Use the cable tie support loops on the side of the Bridge Module to securely fasten it under the dash.

12. Route all wiring away from any pedals or other moving components. Using the cable ties supplied, secure the wiring under the dash.

13. Reinstall the lower knee panel back in place with the factory hardware. Tuck any excess cable behind it for a clean appearance.

-END, SECTION 6-

Figure 6.3

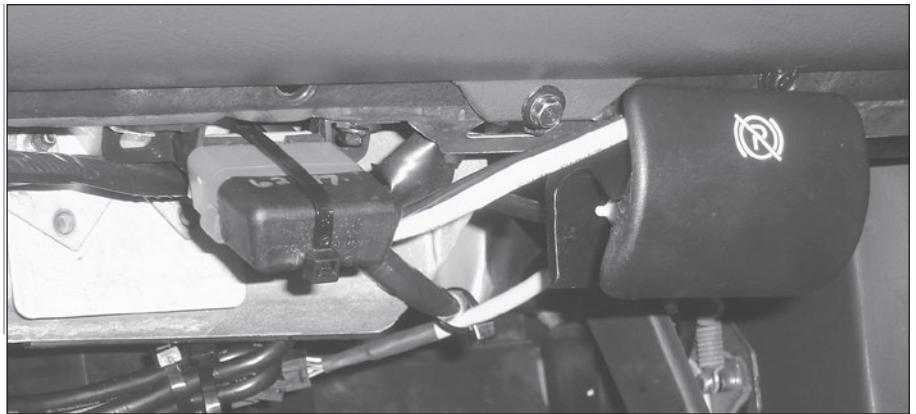

Figure 6.4 Banks iQ System

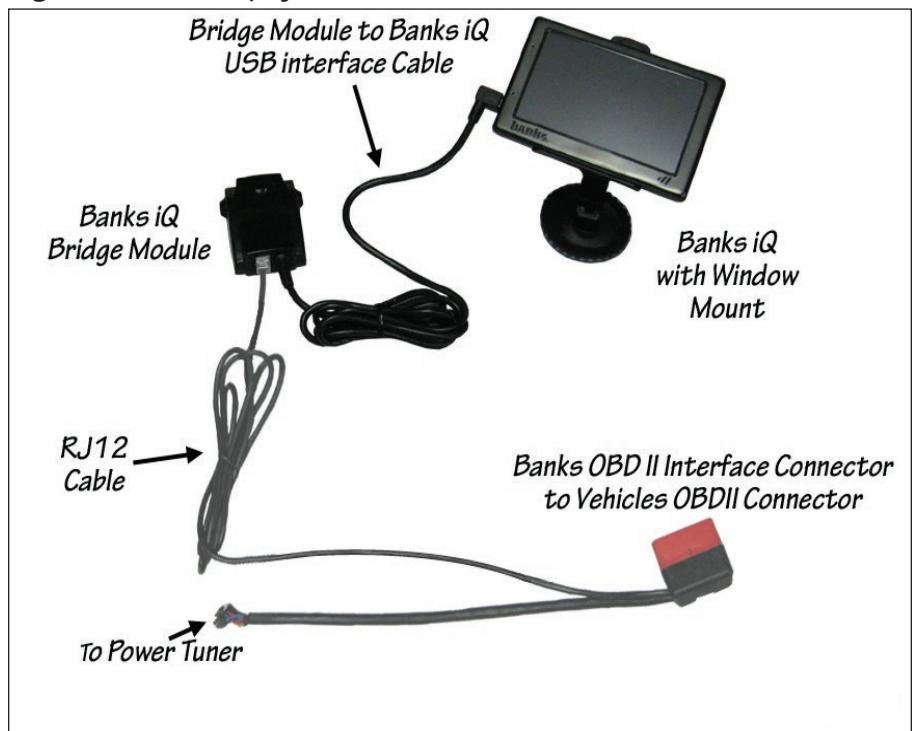
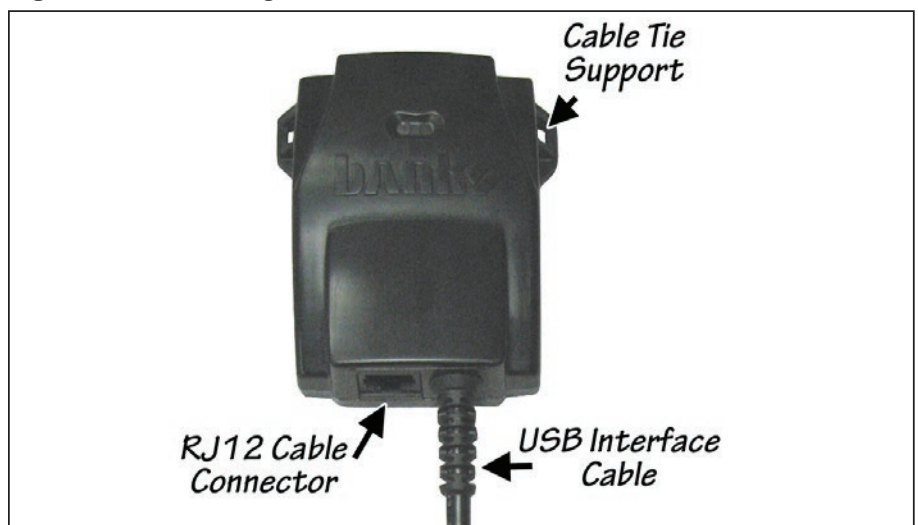

Figure 6.5 Banks Bridge Module



Section 7

INSTALLATION OF THE POWER LEVEL SELECTOR SWITCH

Section 7 not needed if Banks iQ will be installed. Please proceed to **Section 8**.

CAUTION: Do not use force when working on plastic parts. Permanent damage to the part might result.

1. The Power Level Selector switch will be installed on the driver's side of the instrument panel (IP) next to the steering column (see **Figure 7.1**). Carefully remove the IP from the dashboard by slowly pulling outwards from the dashboard around the edges of the IP, allowing the mounting pins to pull free from their dashboard sockets. Automatic transmission equipped vehicles will need to set the parking brake and move the shift lever down to the lowest gear to allow clearance for instrument panel removal.

2. Cut out the supplied template (see **Figure 7.2**) and align the template onto the rear of the IP, squarely seating it on the top of the IP mounting pin (see **Figure 7.3**).

3. Using a $\frac{3}{8}$ " Uni-bit, center the bit onto the $\frac{3}{8}$ " drill location on the template and slowly drill through the IP. Using a $\frac{1}{8}$ " drill bit, center and drill through the $\frac{1}{8}$ " location on the template. Remove and discard the template and any plastic shavings.

Figure 7.1

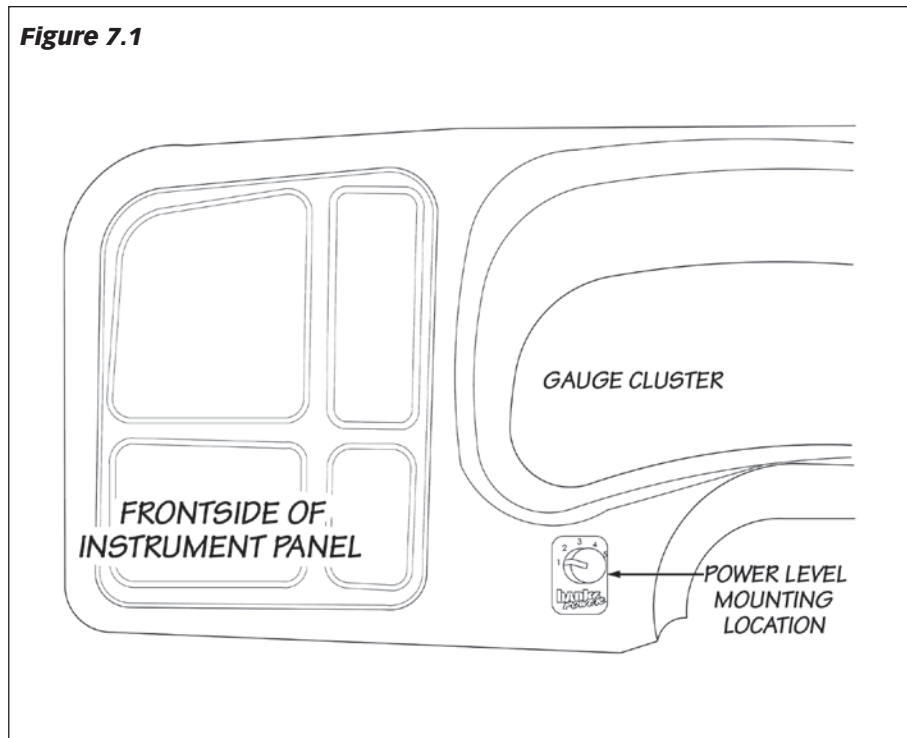

4. On the front side of the IP, align the Power Level Selector Switch label onto the previously drilled hole (see **Figure 7.4**).

5. Remove the nut and internal tooth washer from the Power Level Selector Switch. Rotate the shaft

counter clockwise until the shaft stops. Verify the locating washer tab is inserted into the #6 position on the switch (see **Figure 7.5**).

NOTE: If the washer is in any position other than the #6, your EconoMind Tuner will not select power levels properly.

Figure 7.2 Power level selector switch template

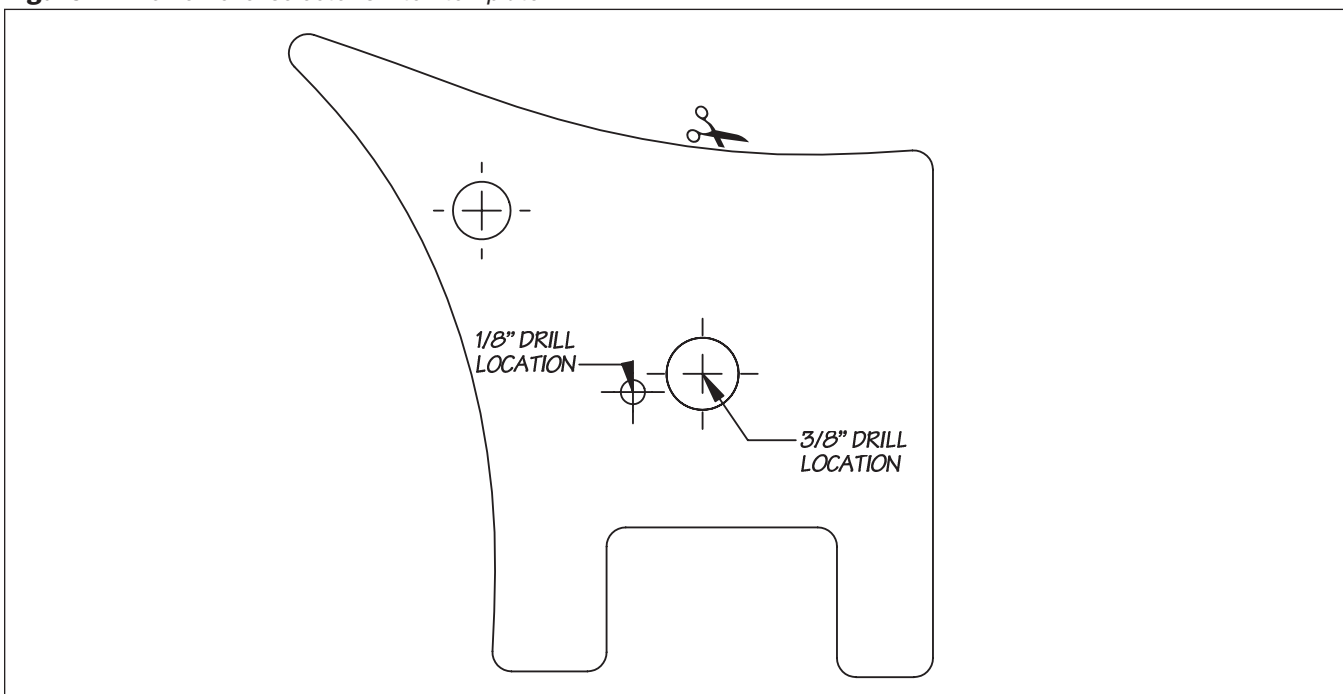

6. After confirming the locating washer is in the #6 location, install the switch through the $\frac{3}{8}$ " hole on the backside of the instrument panel. The alignment pin should rest in the $\frac{1}{8}$ " hole and with the switch fully rotated counter clockwise; the shaft's flat side should be facing the steering column. Secure switch with internal tooth washer and nut. Snug the washer; be careful not to over torque the nut and damage the plastic threads.

7. Install the knob onto the shaft facing the #1 Level on the Power Level Selector Switch label. On the knob, snug the two (2) set screws with the supplied 0.050" hex key wrench.

8. Route the Power Level Selector Switch cable down to the EconoMind Tuner's three-connector cable underneath the dashboard, and reinstall the IP to the dashboard.

9. Connect the Power Level Selector Switch Cable's 2-pin receptacle to the 2-pin plug on the EconoMind Tuner's grey three-connector cable. Reconnect the ground cables to the vehicle batteries.

-END, SECTION 7-

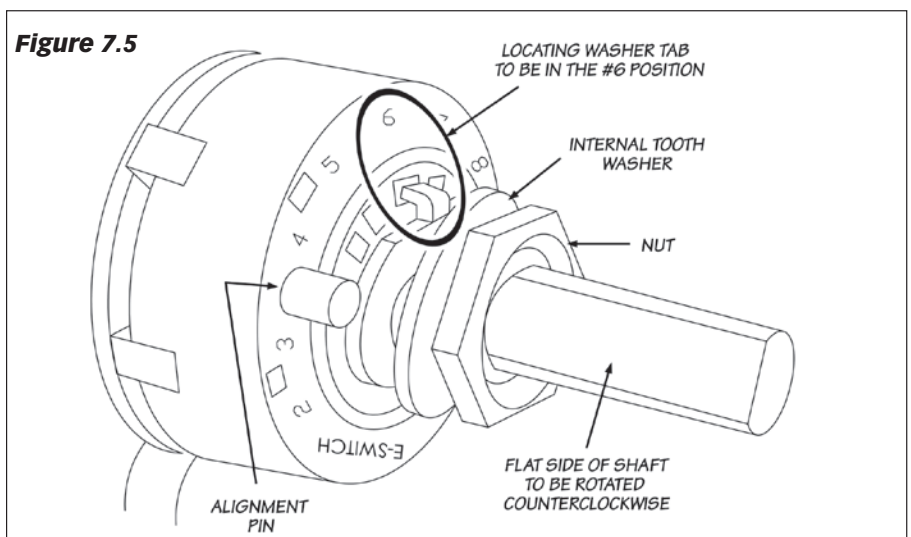
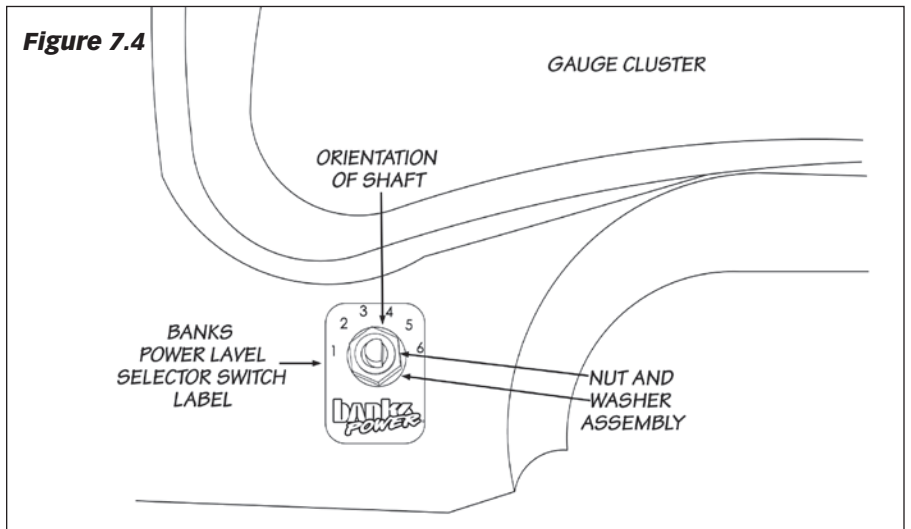
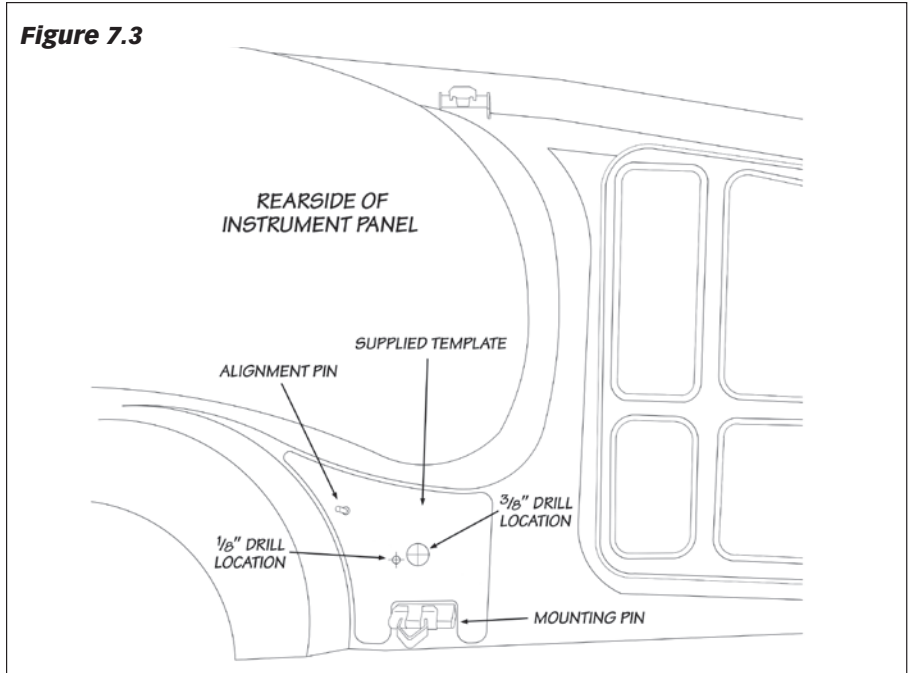

Section 8

OPTIONAL GAUGE CLUSTER INSTALLATION

If not installing optional gauges, skip to next section.

1. Choose a suitable location under the lower edge of the dash for the mounting of the instrument panel provided where the driver can conveniently view it.

NOTE: Molded pillar mount and additional gauges are available through Gale Banks Engineering.

2. Using the panel as a template, drill two $\frac{3}{16}$ " diameter holes in the dash and mount the panel with the supplied machine screws, nuts and star washers provided.

3. Locate the supplied EconoMind wire loom with the 4-pin connector. Connect the 4-pin connector on the EconoMind wire loom to the connection labeled DYNAFACT Gauges on the EconoMind wiring harness. See **Figure 5.0**.

4. Install the DynaFact boost and pyrometer gauges in the mounting panel using the clamps and thumbnuts provided. Plug the BLACK wire lead to the male spade terminal on the BLACK wire of each gauge wire harness. Plug the YELLOW wire into the Yellow wire of the boost gauge wire harness and the RED wire into the RED wire of the pyrometer gauge wire harness. The ORANGE wire remains unused.

5. Connect the 4-pin connector of each gauge into the back of its corresponding gauge.

a. Crimp the remaining Black and RED wires from each 4-pin connector gauge harness to the butt connectors as shown in **Figure 8.1**.

b. Strip one end of the RED wire and crimp it to the butt connector containing the RED wires from step 'a'.

c. Strip one end of the BLACK wire and crimp it to the butt connector containing the BLACK wires from step 'a'.

d. Route the RED wire to the fuse box. Locate the appropriate fuse for instrument lighting in the owner's manual. Cut the RED wire as required and strip the end. Crimp the push on connector to the RED wire and connect to the fuse as shown in **Figure 8.1**. Alternatively, locate power wire to dimmer switch and install T-tap. Cut the RED wire as required and strip the end. Crimp the push on T-tap connector to the RED wire and connect to T-tap on dimmer power wire.

e. Locate a metal surface that will serve as an acceptable chassis ground. Cut the BLACK wire to a sufficient length that will allow it to reach the chassis ground and strip the end. Crimp the ring terminal to the BLACK wire as shown in **Figure 8.1**.

f. Drill a $\frac{1}{8}$ " hole, if required, to attach the ring terminal to the chassis ground. **Caution: If drilling, check the backside to make sure there are no components that may be damaged by drilling.**

g. Use the supplied self-tapping screw to secure the ring terminal to the chassis ground.

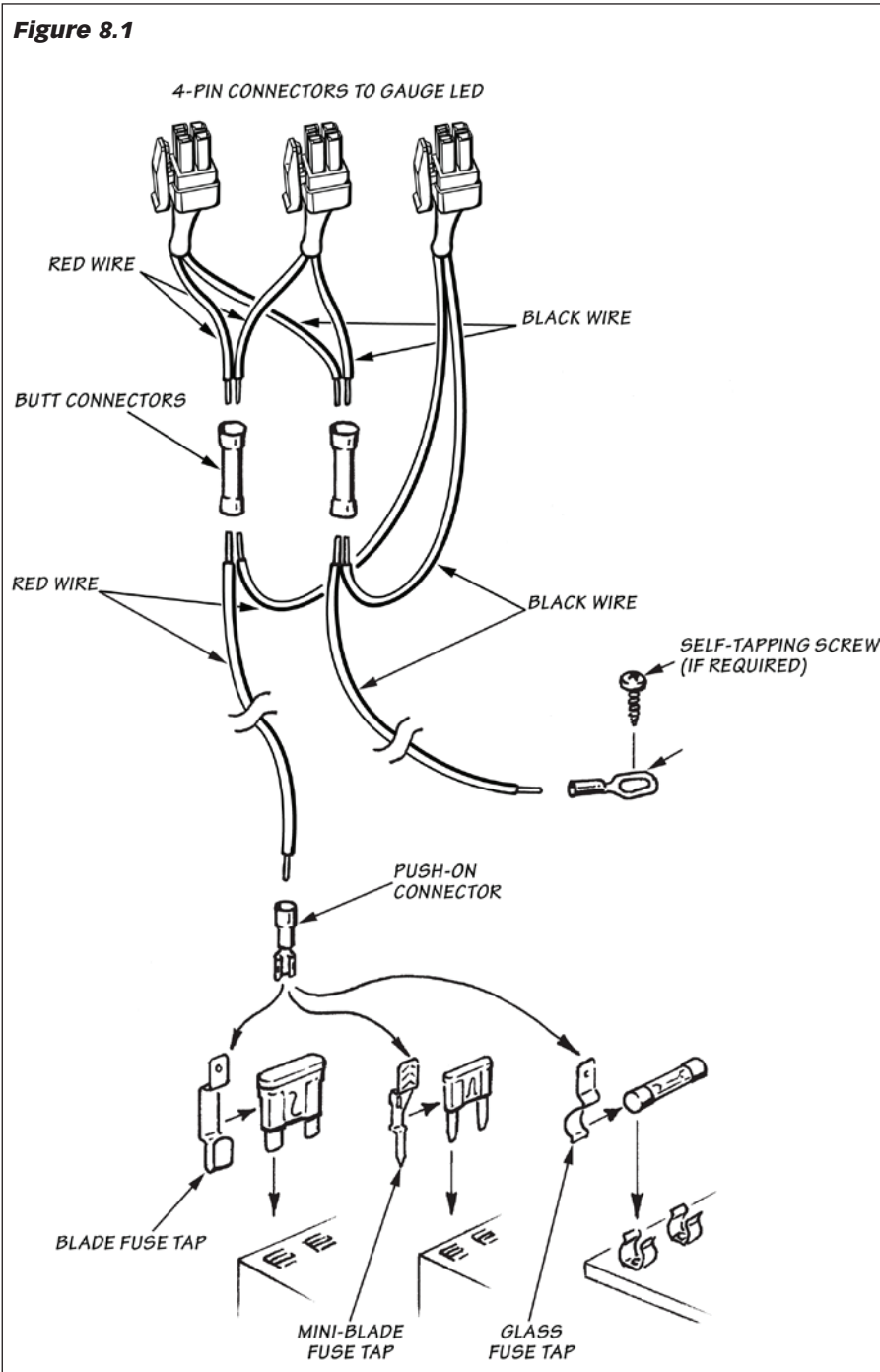

Section 9

AUTOMATIC TRANSMISSION LEARNING

NOTE: Please refer to the Banks iQ Software & Installation Kit, Owners Manual for software installation and operation instruction before beginning Section 9, Automatic Transmission Learning.

The 6.6L GM Duramax Trucks equipped with the Allison 1000 5-speed automatic overdrive transmission use adaptive shift control logic. This will require the transmission to adapt to the additional power created by the Banks Power products before it will shift properly. Failure to follow the sequence can result in damage to the transmission. Perform the following sequence at a location where it is safe to accelerate without exceeding the posted speed limit.

1. With the power selector on level one, start the truck and allow the engine to reach normal operating temperature.
2. Switch to power level two.
3. Drive vehicle in power level two for 5 to 10 miles ensuring a complete shift cycle though each gear. (The transmission shift adaptation learning process requires 15 to 30 complete shift cycles to learn new shift program.)
4. Repeat step 3 for each power level.

WARNING: Take particular care not to do wide open runs in 5th gear when in Automatic transmission Learning Mode. The Allison 1000 5-speed automatic transmission will continually

adapt to the power output of the engine to optimize shift quality. The transmission will quickly adapt to the power setting if the driving cycle includes regular gear changes at high loads. The transmission learning procedure will need to be repeated when switching back to the higher power settings once the transmission adapts to the lower power settings. It will be apparent when the transmission adapts to the lower settings by monitoring the feel of the gearshift. Gear changes will be noticeably harder when initially switching from a higher to lower power setting. This will soften as the transmission adapts to the new setting.

-END, SECTION 9-

Section 10

TROUBLESHOOTING, ECONOMIND

EconoMind Troubleshooting Using The Banks iQ

Check the Banks iQ's Status indicator for the "OK" icon on the upper left corner of the iQ screen. Any Tuner fault will be indicated by the "Banks Engine" icon (see **Figure 10.1**) and its cause can be investigated by running a 'Power Diagnostic' from the Diagnostic menu.

Figure 10.1



*Banks Engine
Icon*

1. In the Environment select menu press on the 'Diagnostics' button. See **Figure 10.2**.
2. In the Diagnostics menu press on the 'Tuner Diagnostics' button to run a tuner diagnostics. See **Figure 10.3**.
5. The 'Self Diagnostic' screen displays a log of diagnostic events related to the Power Tuner. The 'Logged Events' list takes a moment to update each time this screen is opened. Once the list is updated,

Figure 10.2



the most current event will appear at the bottom of the list. Each event has an associated timestamp and description, which will be displayed below the list when that event is highlighted. Each key cycle of the vehicle produces a minimum of two logged events. See **Figure 10.4**. **Table 1** lists the common diagnostic codes and the suggested Course of Action for each.

6. Use the arrow buttons to scroll through the recorded events
7. Touch the Banks iQ icon on the lower left of the screen to return to the environment screen or the Return icon to return to the Diagnostics menu.
8. A pop-up "Log-File" screen will appear asking you if you want to erase the contents of the log. Press 'No' to keep the contents on Log-file or 'Yes', to erase the Log-files.

Figure 10.3

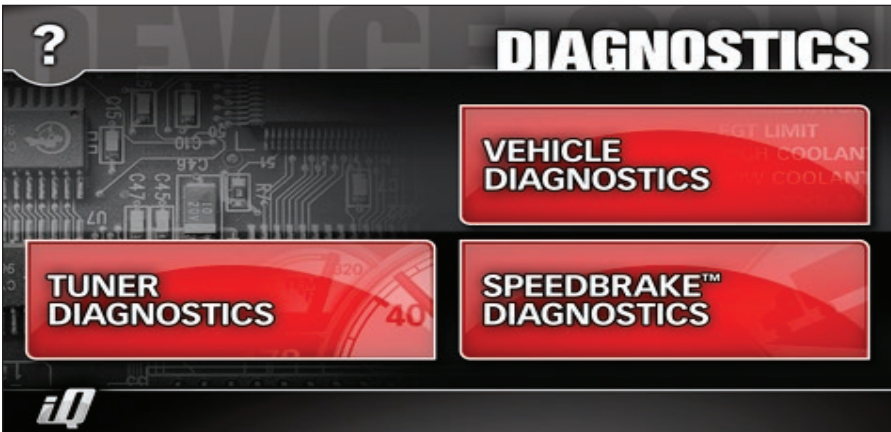
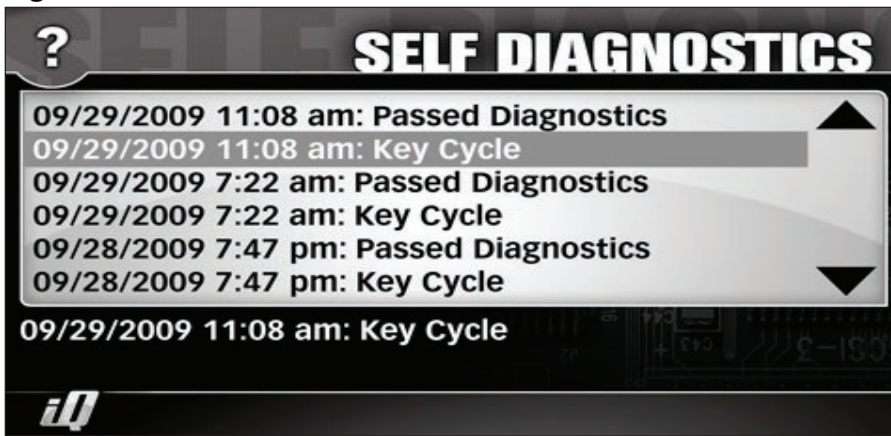

Figure 10.4



Diagnosing EconoMind error codes without Banks iQ.

If you feel that your Banks EconoMind Diesel Tuner is not functioning properly, some diagnostics can be performed. Your EconoMind Diesel Tuner is equipped with diagnostic features that will detect and display certain errors.

Remove the Banks EconoMind Diesel Tuner from its mounting location while keeping all connectors plugged in, and position it in such a way that you can view the end of the EconoMind housing that contains the LEDs from the driver's seat. Turn the vehicle key to the ON position.

Observe the two LEDs mounted on the end of the Banks EconoMind Diesel Tuner:

- A steady GREEN LED will illuminate if all wire connections are correct, the engine is running, and the engine coolant temperature is within its normal operating range.
- The GREEN LED will flash if all wire connections are correct, the engine is running, but the engine coolant temperature is not within its normal operating range. The GREEN LED will stop flashing once the engine coolant temperature is within its normal operating range.

• No LEDs will illuminate if the fuse on the EconoMind wiring harness is blown or the wiring harness is not properly connected. If the fuse and all connections are okay, contact Banks Technical Service.

• The RED LED will flash in a certain sequence if a connection is incorrect or if there is a problem with the system – this sequence will identify one or more diagnostic codes. A Banks EconoMind Diesel Tuner's diagnostic code is comprised of 2 digits. Each code is expressed in a sequence of 2 sets of the flashing red LED separated by a brief flashing of the green LED in between. Each set of a number of red LED flashes represents a digit. A longer flashing of the green LED separates the sequences. The LEDs will continue to flash to display all the errors, and then repeat. **Table 1** lists the common diagnostic codes. For example, if a faulty thermocouple is detected (code "2,3") by the Banks EconoMind Diesel Tuner, the following red and green LED flashing sequence is observed when the key is on:

- (1) Two times flashing RED LED
- (2) One time quick flashing GREEN LED
- (3) Three times flashing RED LED
- (4) One time longer flashing GREEN LED

The above flashing sequence will repeat continuously. When the problem is corrected, the diagnostic code will be eliminated and replaced by a steady green light.

NOTE: If multiple codes are set, they will be displayed in a series separated by the longer flashing green LED. When reading codes, make sure to watch the entire series until you see the first code repeat.

-END, SECTION 10-

Table 1 Banks EconoMind Diagnostic Codes

Code	Event	Course of Action
1,1	Fuel Rail Pressure (FPR) Input Voltage Out of Range	Turn ignition OFF and check the 24-Pin and 38-Pin connectors. Turn ignition back ON and re-check for presence of code.
1,2	Manifold Absolute Pressure (MAP) Input Voltage Out of Range.	Turn ignition OFF and check the 24-Pin and 38-Pin connectors. Turn Ignition back ON and re-check for presence of code.
1,3	EconoMind Switch Input Value Out of Range	Turn ignition OFF and make sure either Banks iQ or EconoMind switch is connected to EconoMind tuner. If EconoMind switch is connected (no Banks iQ), check 2-pin connection on tuner's in-cab cable. Turn ignition back ON and re-check for presence of code. I
1,4	(LB7) Barometric Pressure Input Voltage Out of Range	Turn ignition OFF and check the 24-Pin and 38-Pin connectors. Turn ignition back ON and re-check for presence of code.
	(LLY) Barometric Pressure CAN Signal Not Available	
2,1	Fuel Rail Pressure (FPR) Output voltage Out of Range.	Turn ignition OFF and check the 24-Pin and 38-Pin connectors. Turn ignition back ON and re-check for presence of code.
2,2	Manifold Absolute Pressure (MAP) Output Voltage Out of Range.	Turn ignition OFF and check the 24-Pin and 38-Pin connectors. Turn ignition back ON and re-check for presence of code.
2,3	Exhaust Gas Temperature (EGT) Sensor Open Circuit.	Turn ignition OFF and check both thermocouple ring-terminal connections. Turn ignition back ON and re-check for presence of code.
2,4	OBD Signal Malfunction	Turn ignition OFF and check OBD connector and cable. Turn ignition back ON and re-check for presence of code.
3,1	Crankshaft Position (CKP) Strand Fault or Internal Module Malfunction.	Turn ignition OFF and check the 24-Pin and 38-Pin connectors. Turn ignition back ON and re-check for presence of code.
3,2	Power Up Error or Internal Module Malfunction	Turn ignition OFF and check the 24-Pin and 38 Pin connectors. Turn ignition back ON and re-check for presence of code.
3,3	Low Battery Voltage or Internal Module Malfunction.	Turn ignition OFF and check the 24-Pin and 38-Pin connectors. Turn ignition back ON and re-check for presence of code.
3,4	CAN Communications Error with Vehicle.	Turn ignition OFF and check the 24-Pin and 38-Pin connectors. Turn ignition back ON and re-check for presence of code.
4,1	Injection Control Signal Fault or Internal Module Malfunction	Turn ignition OFF and check the 24-Pin and 38-Pin connectors. Turn ignition back ON and re-check for presence of code.
4,2	Transmission slippage Detected	Transmission is slipping excessively. Code will automatically clear once transmission stops slipping (repaired).
5,1	Internal Module Malfunction	Turn ignition off. Turn ignition back ON and re-check for presence of code.

If problem persists, call Gale Banks Engineering Tech Support.

Section 11

CLEARING LEARNED PARAMETERS

If the Banks EconoMind Diesel Tuner has been moved to a different vehicle, or you are instructed to do so by Banks Technical Staff, it is possible to reset all of the parameters that the EconoMind has 'learned'.

CAUTION: The following procedures can only be carried out with the engine OFF!

1. Turn the vehicle key to ON but **DO NOT** start the engine.

2. Fully depress the throttle pedal and then release it completely. Repeat 5 times. The GREEN LED will flash when this is completed successfully.

3. Turn the key OFF. Wait 30 seconds, or until the GREEN LED goes

off and stays off. Turn the key back to the ON position but **DO NOT** start the engine.

4. Fully depress the throttle pedal and then release it completely. Repeat 5 times

-END, SECTION 11-

Section 12

REMOVAL OF THE ECONOMIND DIESEL TUNER

If the Banks EconoMind Diesel Tuner should ever need to be removed from the vehicle, perform the following:

1. Disconnect the EconoMind's 38-pin connector from the factory harness.

2. Re-connect the vehicle's 38-pin connector back into the factory harness.

3. Disconnect the EconoMind's 24-pin connector from the factory harness.

4. Re-connect the vehicle's 24-pin connector back into the factory harness.

5. Disconnect the 2-ring terminals from the EGT thermocouple.

6. Disconnect the 3 small connectors on the 'In-Cab Cable' and gently pull the cable back through the firewall.

7. Remove the Banks EconoMind Diesel Tuner.

NOTE: Failure to follow the above instructions when removing the module will result in a "Check Engine" light on the dash and a Diagnostic Trouble Code being stored in the factory computer, in addition to the engine not running.

-END, SECTION 12-

Section 13

FILTER MAINTENANCE

OILED AIR FILTER ONLY

NOTICE: The Banks Ram-Air Oiled Air Filter comes pre-oiled and no oiling is necessary for initial installation. Use Banks Ram-Air Filter Cleaning System (part#90094), available from Gale Banks Engineering to service the Air Filter. Follow the instructions included with the cleaning system to clean and re-oil your Bank Ram-Air Oiled Air Filter.

1. PRE-CLEANING

Tap the element to dislodge any large embedded dirt, then gently brush with a soft bristle brush. *NOTE: If complete cleaning is not practical at this time, reoil the element and reinstall in your vehicle.*

2. SPRAY-ON CLEANING

Spray air-filter cleaner liberally onto the entire element and let soak for 10 minutes.

3. PAN CLEANING

Large air-filter elements can be rolled or soaked in a shallow pan of air-filter cleaner. Remove immediately and let soak for

approximately 10 minutes.

NOTICE: NEVER use gasoline, steam, caustic solutions, strong detergents, high-pressure nozzles, or cleaning solvents to clean the filter element. All of these can cause harm to the filter media as well as SHRINK and HARDEN the rubber end caps.

4. RINSING

Rinse off the element with low-pressure water. Tap water is okay. Always flush from the clean side to dirty side. This removes the dirt and does not drive it into the filter.

5. DRYING

Always dry naturally. After rinsing, shake off all excess water and let the element dry naturally.

6. AEROSOL OILING

After cleaning air filter always reoil before using. Spray air filter oil down into each pleat with one pass per pleat. Wait 10 minutes and re-oil any white spots still showing.

7. OILING HINTS

Never use a Banks Ram-Air filter without oil (the filter will not stop

the dirt without the oil). Use only air filter oil. Air-filter oil is a compound of mineral and animal oil blended with special polymers to form a very efficient tack barrier. Red dye is added to show just where you have applied the oil. Eventually the red color will fade but the oil will remain and filter the air. NEVER USE Automatic Transmission Fluid. NEVER USE Motor Oil. NEVER USE Diesel Fuel. NEVER USE WD40, LPS, or other light-weight oils.

8. REINSTALL

Reinstall your Banks Ram-Air filter element with proper care. Make sure the element seats properly in the filter case. Install the cover making sure it's in the right position. Tighten all the nuts, bolts, screws or clips to factory specifications.

9. DO NOT DISCARD

Affix the "Do Not Discard" sticker to the filter case (included with every Banks replacement element). Make sure you put the sticker in a highly visible place to alert your mechanic not to discard.

10. PERFORMANCE HINTS

Service every 50-100,000 miles on

street-driven applications. Service more often in offroad or heavy-dust conditions. If an air-filter restriction gauge is installed, then change the element when the air-filter restriction reaches 18"–H.O.

⚠ CAUTION: **Extremely fine dust from agriculture or offroad use will pull the oil from the element. Frequent reoiling of the element's clean side might be required. Completely service when practicable. For extra protection use an air-filter sealing grease on rubber ends of the element. Service only with air-filter cleaner and air-filter oil.**

DRY FILTER CLEANING

Clean every 50-100,000 miles on street-driven applications. Clean more often in offroad or heavy-dust conditions. If an air-filter restriction gauge is installed, then change the element when the air-filter restriction reaches 18"–H.O.

1. PRE-CLEANING

Carefully tap the air filter element to dislodge any large embedded dirt or debris.

2. CLEANING

Spray an appropriate DRY AIR-FILTER CLEANER SOLUTION liberally onto both sides of the entire filter element with the majority applied to the dirty side. Soak for 10 minutes. Do not allow the DRY AIR-FILTER CLEANER SOLUTION to dry on the air filter.

NOTICE: **NEVER use gasoline, steam, caustic solutions, strong detergents, high-pressure nozzles, or cleaning solvents to clean the filter element.** All of these can cause harm to the filter media as well as SHRINK and HARDEN the rubber end caps.

3. RINSING

Rinse the filter element with cool or warm (not hot) water from the clean side out in order to flush the dirt out of the filter. It may be necessary to use your fingers on the hose to apply light water pressure. Repeat steps 2 and 3, until the water flowing through the media is completely clear of any dirt and debris.

5. DRYING

After rinsing, gently shake off excessive

water and allow to dry naturally. Reinstall the filter onto the intake system, airbox or custom assembly once it is dry or just slightly damp. Follow all original installation instructions.

6. REINSTALL

Reinstall your Banks Ram-Air filter element with proper care. Make sure the element seats properly in the filter case. Install the cover making sure it's in the right position. Tighten all the nuts, bolts, screws or clips to factory specifications.

7. DO NOT DISCARD

Affix the "Do Not Discard" sticker to the filter case (included with every Banks replacement element). Make sure you put the sticker in a highly visible place to alert your mechanic not to discard.

8. PERFORMANCE HINTS

Service every 50-100,000 miles on street-driven applications. Service more often in offroad or heavy-dust conditions. If an air-filter restriction gauge is installed, then change the element when the air-filter restriction reaches 18"–H.O.

-END, SECTION 13-

Section 14

PLACEMENT OF THE BANKS POWER DECALS

Figure 14.1

