

**banks**

with Installation Instructions  
**Owner's Manual**

# **Banks Monster<sup>®</sup> Exhaust System**

**2017+ Ford Power Stroke 6.7L  
Turbo-Diesel F-250/F-350/F-450 Trucks**

THIS MANUAL IS FOR USE WITH SYSTEM 49794

**BANKS**

# General Installation Practices

1. Before starting work, familiarize yourself with the installation procedure by reading all of the instructions.
2. The exploded view (**Figure 1**, pages 4-5) provides only general guidance. Refer to each step and section diagram in this manual for proper instruction.
3. Throughout this manual, the left side of the vehicle refers to the driver's side, and the right side to the passenger's side.
4. Disconnect the negative (ground) cable from the battery (or batteries, if there are two) before beginning work.
5. Route and tie wires and hoses a minimum of 6" away from exhaust heat, moving parts, and sharp edges. Clearance of 8" or more is recommended where possible.
6. When raising the vehicle, support it on properly weight-rated safety stands, ramps or a commercial hoist. Follow the manufacturer's safety precautions. Take care to balance the vehicle to prevent it from slipping or falling. When using ramps, be sure the front wheels are centered squarely on the topsides. When raising the front of the vehicle, put the transmission in

park (automatic) or reverse (manual), set the parking brake, and block the rear wheels. When raising the back of the vehicle, be sure the vehicle is on level ground and the front wheels are blocked securely.

**CAUTION! Do not use floor jacks to support the vehicle while working under it. Do not raise the vehicle onto concrete blocks, masonry or any other item not intended specifically for this use.**

7. During installation, keep the work area clean. Do not allow anything to be dropped into intake, exhaust, or lubrication system components while performing the installation, as foreign objects will cause immediate engine damage upon start-up.

## **TOOLS REQUIRED:**

- 1/2" and 3/8" drive ratchets with inch and metric sockets and 1/2" and 3/8" drive extension
- Inch and metric combination or open-end wrenches
- Standard screwdriver
- Clean shop towels or rags
- Pry-bar

## **HIGHLY RECOMMENDED TOOLS AND SUPPLIES:**

- Penetrating oil or light lubricant spray



**Banks Ram-Air® Intake System  
(P/N 41824)**

- Increases your airflow over stock.
- Adds power, improves fuel economy, lowers EGTs and reduces smoke.

**Banks Monster Exhaust System  
Chrome Tip (P/N 49794)  
Black Tip (P/N 49794-B)**

- Provides increased air flow to the engine by increasing air density for more increased power, lower EGTs and improved fuel economy.

**Banks iDash 1.8 Gauge  
(P/N 66560)**

- Customizable gauge display
- Read Boost Pressure, EGT and so much more
- Avoid costly repairs by monitoring important sensors
- Display 2-8 values
- Read up to 80 OBDII Mode 01 values
- Over 300 parameters available
- View Data your dash does not display
- Displays accurate values your OEM dash gauges filter
- Includes patented OBDII Density (exclusive to Banks)
- Log up to 20 min/max values
- Optional Data-Logging records up to 100 values continuously
- Built-in Shift & RPM Light
- Connect multiple iDash 1.8 gauges
- Auto-Dimming Feature
- Fits standard 52mm (2-1/16 inch) gauge mounts
- Allows forced stationary regen on L5P Duramax

**Figure 1**

# General Assembly Diagram

<b>Item</b>	<b>Description</b>	<b>P/N</b>	<b>Qty.</b>
<b>1</b>	Gasket, Intermediate Pipe	93211	1
<b>2</b>	Intermediate Pipe	53975	1
<b>3</b>	Front Tailpipe	53999	1
<b>4</b>	Rear Tailpipe	53998	1
<b>5</b>	Exhaust band Clamp, 4"	52471	3
<b>6</b>	Tip, Tailpipe	52726	1

*Note: Tighten all Banks Exhaust band clamps to 50 ft lbs.*

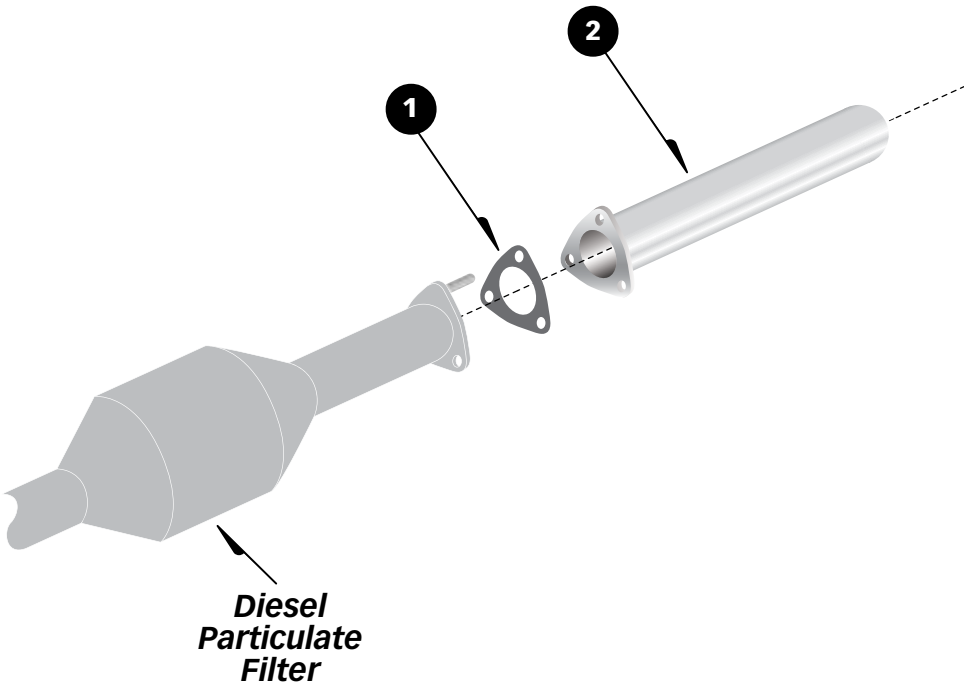

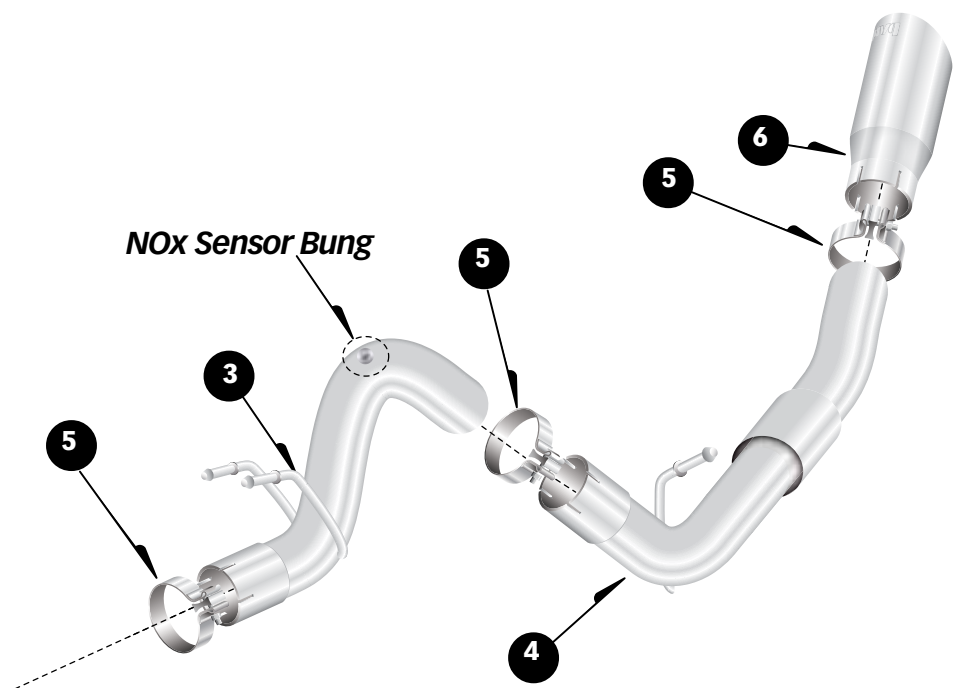

# Monster Exhaust System Installation

**1.** As a precaution, disconnect the ground of the battery (if there is more than one battery, disconnect both).

**2.** Raise the vehicle and support it with properly weight rated safety stands, ramps or a commercial hoist. Follow the manufacturer's safety precautions. Take care to balance the vehicle to prevent it from slipping or falling. When using ramps, be sure the front wheels are centered squarely on the topsides; place the transmission in park; set the parking brake and place blocks behind the rear wheels.

**⚠ CAUTION:** DO NOT WORK UNDER ANY VEHICLE SUPPORTED ONLY BY A JACK. SEVERE INJURY MAY RESULT.

**3.** Remove Factory NOx sensor with a 24 mm wrench and tie safely out of the way to prevent damage. See **Figures 2**.

**Figure 2**



**4.** Remove the factory tailpipe from the vehicle by disengaging the exhaust system hanger pins from the rubber hangers using a large screw-driver or pry bar.

**NOTICE:** Lubricating the rubber hangers with WD-40 or similar lubricant will ease removal of the hanger pins.

**5.** Remove the factory exhaust from the vehicle by removing the three (3) nuts from the factory exhaust flange located at the factory exhaust inlet.

**6.** Locate the supplied intermediate pipe and cut the intermediate pipe based on the following configurations. See **Table 1**. Cut the NON-flanged end of the intermediate pipe. See **Figure 3**.

**7.** Install the Banks intermediate pipe and 3-bolt gasket onto the headpipe.

**8.** Slide the supplied 4" exhaust hanger clamp onto the outlet of the Banks flanged intermediate pipe.

**9.** Route the Front Tailpipe over the rear axle housing. Insert the hanger pins into the factory rubber hanger. Install the Front Tailpipe onto the Banks Intermediate pipe outlet.

**10.** Install the 4" exhaust clamp onto the inlet of the Rear Tailpipe. Start the Rear Tailpipe hanger pin into the corresponding vehicle rubber hanger. Install the Rear Tailpipe over the outlet of the Front Tailpipe. Slide the 4" clamp into position that best supports the tailpipe assembly. Loosely snug the hanger clamp on the intermediate pipe outlet.

**Figure 3**

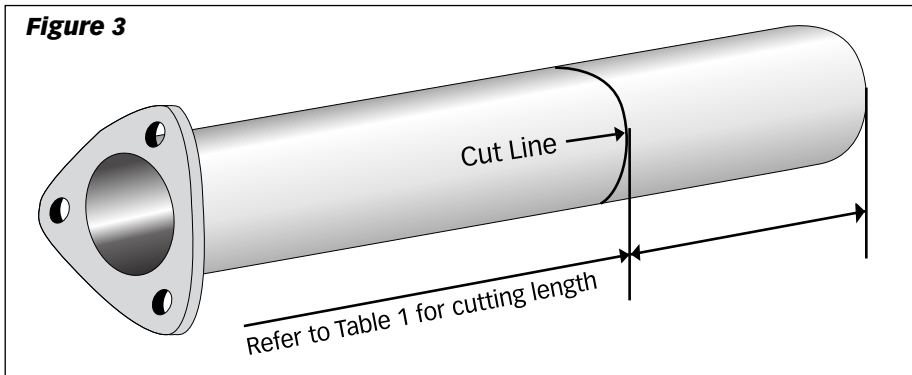

**Table 1.**

<b>2017+ Ford Power Stroke 6.7L</b>		
	Wheel Base	Cut this length from the Intermediate Pipe. See <b>Figure 2.</b>
Reg Cab/ Long Bed	141.6"	34.4
Super Cab/ Short Bed	148"	28.0
Crew Cab/ Short Bed	159.8"	16.2
Super Cab/ Long Bed	164.2"	11.8
Crew Cab/ Long Bed	176"	No Cut

**NOTICE:** Maintain an adequate air gap clearance of one (1) inch between the exhaust and the shock absorber and between the exhaust and the spare tire.

**11.** Install Banks Monster tailpipe tip with exhaust band clamp on the exhaust. Keep the wrapping on until installation is complete. Adjust the tip past the edge of the body or where aesthetically pleasing. Loosely snug the 4" clamp.

**NOTICE:** Minimum distance between exhaust tip and body is one (1) inch.

**12.** With everything positioned properly, begin to tighten the clamps starting with the ones closest to the turbo and working your way back. Tighten all clamps to 50 ft lbs.

**13.** Re-install factory NOx sensor into Banks exhaust bung. Tighten by hand until snug, then with a wrench: 1/8-1/4 turn.

**14.** Remove the protective covering from the tailpipe tip.

**CAUTION:** THE PROTECTIVE COVERING MAY IGNITE AND BURN IF NOT REMOVED PRIOR TO RUNNING THE ENGINE.

**15.** Your system includes two "Banks Power" logos designed to complement the Ford badging on your truck. See **Figure 4** to position the logos for a clean factory look.

**16.** Re-connect battery terminals if previously removed. Banks Monster Exhaust installation is now complete.

**Figure 4**

