

banks

with Installation Instructions

Manual

Banks Power Pack® System

**Including Banks Stinger® System
Banks TorqueTube System**

**2006-2015 Ford 6.8L V-10
Class-A Motorhome**

THIS MANUAL IS FOR USE WITH SYSTEMS 49170-49172, 49175, 49176, 49177

banks

General Installation Practices

1. For ease of installation of you Banks system, familiarize yourself with the procedure by reading the entire manual before starting work.
2. The exploded views provide only general guidance. Refer to each step and section diagram in this manual for proper instruction.
3. Throughout this manual, the left side of the vehicle refers to the driver's side, and the right side to the passenger's side.
4. Disconnect the ground cables from the battery before beginning work. If the vehicle has more than one battery, be sure that the engine primary battery is disconnected. This is necessary for safety and to ease the installation of the passenger side TorqueTube® exhaust manifold.
5. Route and tie wires and hoses a minimum of 6 inches away from exhaust heat, moving parts and sharp edges. Clearance of 8 inches or more is recommended where possible.
6. When raising the vehicle, support it on properly weight-rated safety stands, ramps or a commercial hoist. Follow the manufacturer's safety precautions. Take care to balance the vehicle to prevent it from slipping or falling. When using ramps, be sure the front wheels are centered squarely on the topsides; put the transmission in park; set the hand brake; and place blocks behind the rear wheels. If the vehicle is supported by a hoist, the front wheels may be removed for further accessibility.
7. During installation, keep the work area clean. If foreign debris is transferred to any Banks component. Clean it thoroughly before installing.

CAUTION! Do not use floor jacks to support the vehicle while working under it. Do not raise the vehicle onto concrete blocks, masonry or any other item not intended specifically for this use.

Notification

The Banks Ram-Air Filter comes pre-oiled and no oiling is necessary for initial installation. Service the filter as specified in the Cleaning and Oiling the Banks Ram-Air Filter Section of this manual.

Tools Required

- 5mm 6 point socket
- Saw or torch
- 10mm ratchet wrench
- 10mm swivel socket
- Clean shop towels or rags
- Pry bar or channel lock pliers
- 1/4" and 3/8" drive ratchets with metric sockets and a 1/4" drive extension
- Metric combination or open-end wrenches
- Standard and Phillips head screwdrivers
- Penetrating oil or light lubricant spray
- Standard and phillips head screwdrivers
- Torque wrench

Table of Contents

General Assembly	4
Section 1	6
TorqueTube Manifolds	
Section 2	10
Monster Exhaust Install	
Section 3	13
Ram Air Filter Install	
Section 4	14
Cleaning and Oiling the Banks Ram-Air Filter	
Bill of Materials	16
Ram Air Filter Install	

General Assembly

Figure 1A 2006-2010 Models See Bill of Materials on page 16

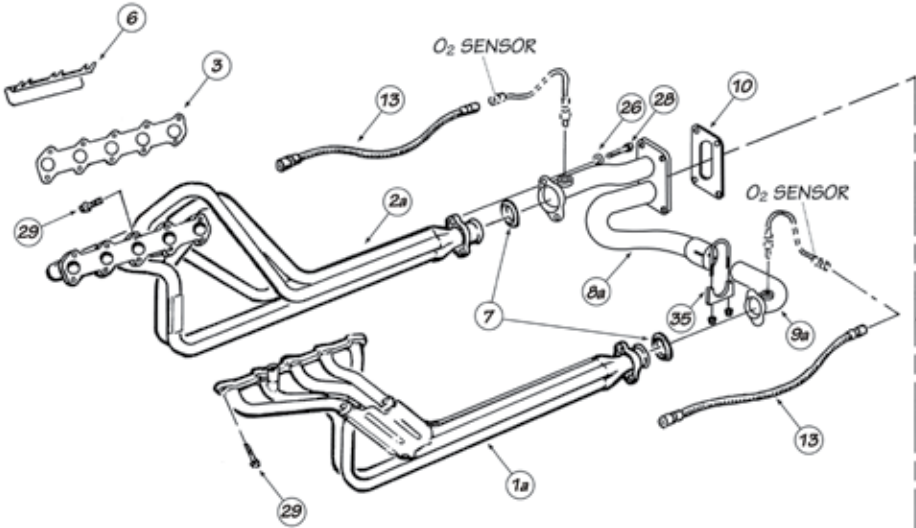

Figure 1B 2011 Models See Bill of Materials on page 16

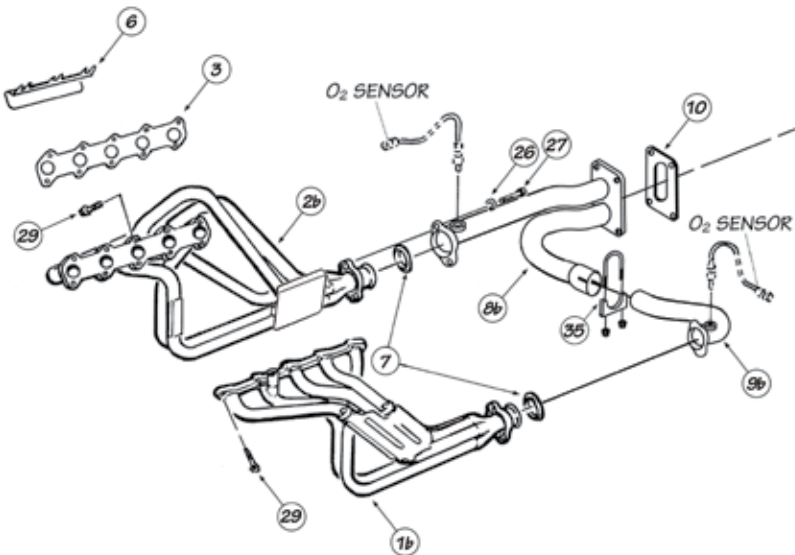
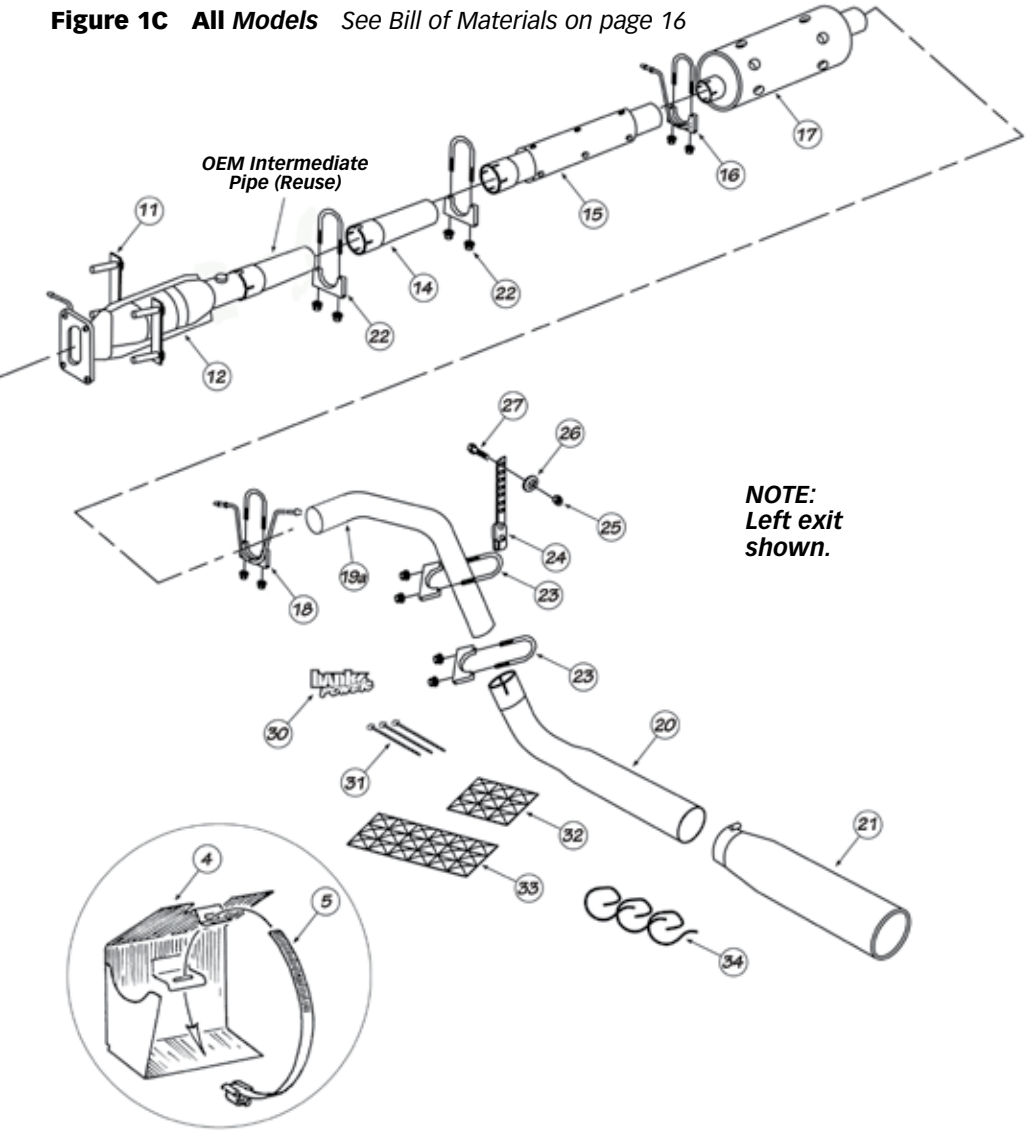

Figure 1C All Models See Bill of Materials on page 16



Section 1

TORQUETUBE MANIFOLDS

Skip to Section 2 for Stinger Install

TORQUETUBE INSTALL

1. With the motorhome safely raised, ground wire(s) disconnected, and precautions in place, remove the factory exhaust system.

2. To provide better access to the manifolds remove the front wheels from the motorhome. If the motorhome is equipped with inner front fender shields, remove them for improved access.

NOTE: Before removing the lug nuts, make sure a capable torque wrench is available to tighten the lug nuts to the manufacturer's torque specifications

3. The vehicle may have a bolted in crossmember between the leveling jacks at the front of the vehicle. This will need to be removed prior to removing the factory exhaust system and reinstalled after the Banks PowerPack system is place.

WARNING: Do not use the leveling jacks while the cross-member is removed.

4. Locate the oxygen sensors in the exhaust headpipes on each side of the engine, forward of the catalytic converters. Unplug the connectors and unscrew the oxygen sensors, keeping track of the left and right sensors. Be careful not to touch or contaminate the sensor.

5. Remove the factory hardware on the front 2-bolt headpipe flanges.

6. Disconnect the four (4) bolt flange at the front of the catalytic converter. Remove the factory Y-pipe from the vehicle. Retain the factory hardware for reassembly.

NOTE: Whenever possible, it is recommended that the catalytic converters be inspected. Restricted or damaged catalytic converters can

impede performance of your Banks PowerPack.

7. Pull out the dipstick and remove the small bolt that attaches the oil dipstick tube to the cylinder head. At the front of the vehicle, behind the front engine cover, remove the 2 screws that retain the dipstick tube to the radiator support. Near the exhaust manifold, pull the dipstick tube up out of the engine block. Check to see if there is an O-ring on the tube. If not, the O-ring may be stuck inside the hole in the engine block. This O-ring should be retrieved if necessary and placed back onto the tube before reinstalling it. Accessing the dipstick may be easier from the interior engine cover (doghouse).

8. To remove the exhaust manifolds, use a wrench or socket to back the nuts away from the manifolds at least one turn, then use a 5mm 6 point socket to remove each stud from the head. As an alternate method, take the nuts off the studs, and then remove the studs.

9. After the manifolds have been removed from the vehicle, remove any remaining studs from the heads. The studs must be removed from the heads in order to install the Banks TorqueTubes.

10. On the passenger side of the engine, loosen the three rearmost outside valve cover bolts. Slide the valve cover heat shield provided under the heads of the bolts and tighten. See **Figure 2**.

11. On some vehicles a wire loom bundle runs along the top of the frame rail adjacent to the side of the engine. In these instances this loom and any other wiring must be relocated away from the TorqueTube heat area. Pry the wire loom clips from the frame rail to provide enough slack in the

Figure 2

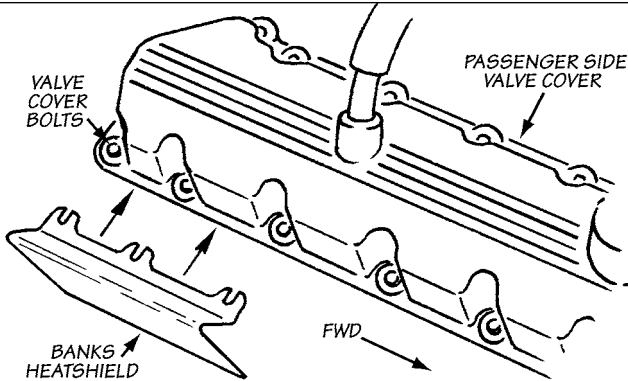

wire loom bundle so it may be routed and tied up against the underside of the floor of the coach. The wire loom bundle may be routed up braces adjacent to the upper engine area and along supporting members under the floor with the wire ties provided.

12. CAUTION: Make sure all ground cables are removed from vehicle's battery(s). Remove the starter wire battery cable from the starter motor. Install the starter heat shield onto the starter using the #52 hose clamp provided.

CAUTION: Make sure the heat shield does not come in contact with the positive terminal of the starter once the heat shield is tightened down. See Figure 3.

13. Inspect the exhaust mounting surfaces of the cylinder heads and clean any rust or carbon deposits, which would prevent the TorqueTubes from sealing. Be careful when doing this as the cylinder heads are aluminum, and can be easily damaged. Banks recommends the use of a plastic scraper. Zip-tie cables away from left-side Torque Tube. Wrap any hoses or harnesses with the supplied heat shield blanket. Secure the blanket to the hose with the supplied wire ties.

Figure 3

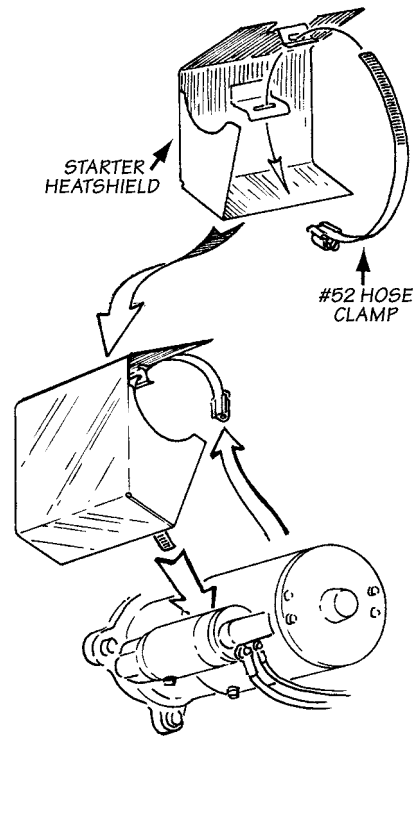

14. Place a small amount of anti-seize on the threads of each of the supplied TorqueTube bolts. Use the new gaskets provided when installing Banks TorqueTubes. The exhaust ports are off-centered so be sure The gaskets are rotated properly.

15. Lift the Banks TorqueTubes and gasket into place and install one or two bolts to hold them in position. Install the remaining bolts into the heads and tighten. Torque the 8mm head bolts to 20 ft-lbs.

16. Make sure the O-ring is on the dipstick tube, and slide the dipstick between the 3rd & 4th Torquetubes. Reinstall the dipstick into the hole in the engine block. Reattach the dipstick tube bracket to the cylinder head with the factory hardware. Reattach the bracket at the radiator support with the factory hardware and put the dipstick back in (See **figure 4**).

WARNING! The following step may require the use of a torch and/or saw. Proper safety equipment should be used. Failure to use proper safety equipment may

result in severe injury.

17. On some vehicles additional clearance may be necessary to install the right side Torque tube. The Undercarriage Power Platform may be slightly modified by cutting away the frame plate corner without disrupting structural integrity. From underneath the vehicle, measure by leaving 1/4" clearance around the nut and beam and mark the location. Using a reciprocating saw, cut the platform plate (See **figure 4b**).

18. If additional clearance at the front of the right side TorqueTube for the air conditioning hose is needed, very gently bend the line away from the TorqueTube until there is a minimum of 1" of clearance. Do not use a pry bar or other tool to bend it as this may damage the line. Wrap the air conditioning line with the heat shielding blanket provided, and tie it with the supplied wire ties.

19. If it was removed, reinstall the hydraulic jack crossmember at the front of the vehicle.

20. Place the new catalytic converter flange gasket onto the 2-bolt studplate

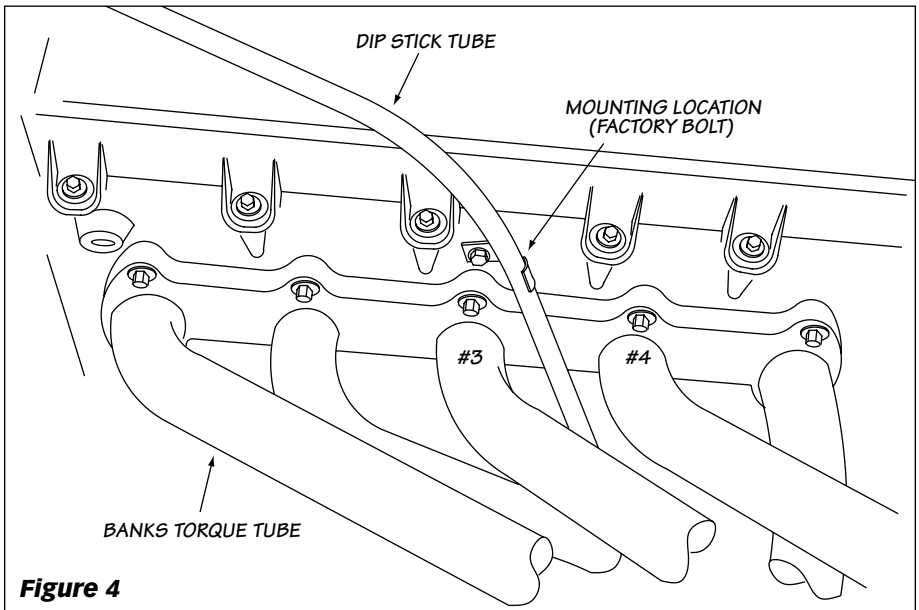
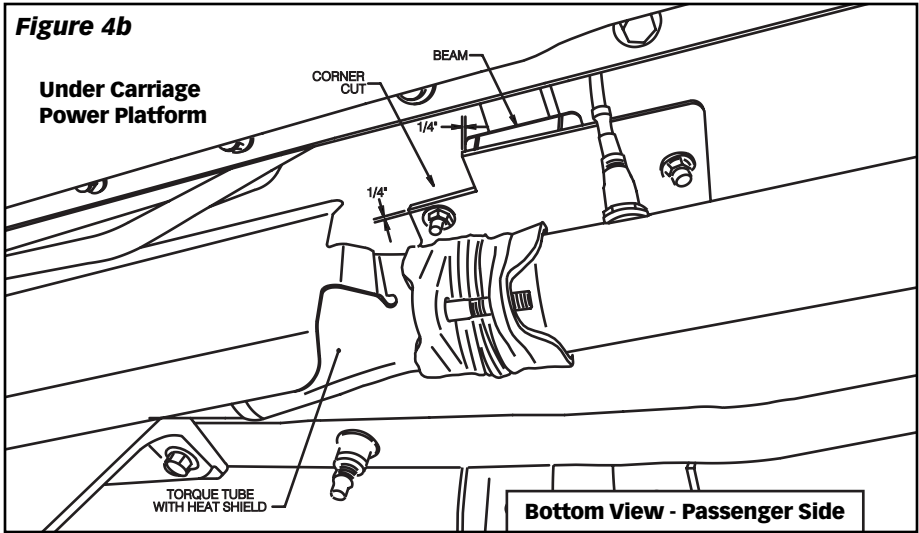

Figure 4

Figure 4b



on the catalytic converter flange. Install the Y-pipe onto the catalytic converter using the original hardware.

21. Place a conical seal into the flare at the right side of the Y-pipe, and attach the Y-pipe to the right side TorqueTube using the $\frac{3}{8}$ " x $1\frac{3}{4}$ " bolts and washers provided. Do not tighten the bolts yet.

22. Place a $2\frac{1}{2}$ " clamp onto the y-pipe extension outlet. Install the y-pipe extension outlet into the right-side y-pipe. Place the second conical seal onto the flare on the left-side of the y-pipe extension. Attach the y-pipe to the left side TorqueTube with the $\frac{3}{8}$ " x $1\frac{3}{4}$ " bolts and washers provided. Tighten and torque all $\frac{3}{8}$ " hardware to 35 ft-lbs.

23. Install and tighten the oxygen sensors into the threaded bungs provided on the Y-pipe & Y-pipe extension. Use a small amount of anti seize on the threads of the oxygen sensors. Be careful to not get any anti-seize on the sensor elements themselves.

24. For 2011 models skip to step 26,

For all other models supplied with Banks O2 sensor extension harness, remove the two index pins on the factory oxygen sensor connector and on the factory sensor extension

lead male connector by cutting or filing. Be careful not to damage the locking mechanism of the connectors. See **Figure 5.**

25. Plug the Banks oxygen sensor (O2) extension harness into the factory O2 harness where each sensor was previously connected. Plug the O2 sensor into the opposite end of Banks extension harness. Secure the leads away from any pipes or moving linkages with the wire ties provided.

26. Using the supplied heat shield blanket and steel ties, wrap the passenger side fuel lines between the frame and transmission. Wrap the parking brake cable on the rear of the transmission.

Figure 5

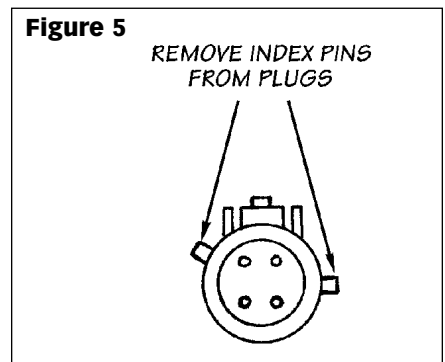

Section 2

MONSTER® EXHAUST INSTALL

1. Disconnect the negative (ground) cable from the battery (if there is more than one battery, disconnect both negative cables). Secure the cable so it cannot accidentally come in contact with the post.

2. Raise the vehicle and support it securely with properly weight-rated safety stands, ramps or a commercial hoist. Take care to balance the vehicle to prevent it from slipping or falling. When using ramps, be sure the wheels are centered squarely on the topsides. Place the transmission in park (automatic) or reverse (manual), set the parking brake and securely block the wheels that are on the ground.

CAUTION: DO NOT WORK UNDER ANY VEHICLE SUPPORTED ONLY BY A JACK. SEVERE INJURY MAY RESULT.

WARNING! The following step may require the use of a torch and/or saw. Proper safety equipment should be used. Failure to use proper safety equipment may result in severe injury.

3. Begin removing the factory exhaust starting at the muffler. Remove the muffler and tailpipe assembly by removing the clamps or cutting the through the pipe near the joints. Remove tailpipe hanger pin from the rubber hanger.

NOTE, to remove the factory exhaust, an oxy-acetylene torch can be used to heat the factory joints to allow the crimped pipes to separate.

4. Remove muffler's dual rear hanger pins and single front hanger from the rubber hangers. Remove the tailpipe and muffler.

5. Slide a 3" saddle clamp over the inlet of the Banks intermediate pipe (smaller pipe). Install the Banks intermediate pipe and clamp over the factory intermediate pipe outlet. If no

factory intermediate pipe is installed, align the Banks intermediate pipe notch with the catalytic converter pin. Snug the 3" clamp.

NOTE: all clamps should be positioned at the beginning of the slots (on the 1/2 circle punch) and evenly tightened.

6. Install a 3" saddle clamp onto the inlet of the Banks heat-shielded rear intermediate pipe. Install the Banks rear intermediate pipe onto the front intermediate pipe outlet. Snug the 3" clamp.

7. Install the front hanger clamp (single pin) onto the intermediate pipe outlet. Insert the hanger pin into the rubber hanger. Install the Banks Monster muffler onto the intermediate pipe outlet (see **Figure 6**).

8. Install the rear hanger clamp onto the Monster muffler outlet. Rotate the muffler such that the inlet is at the bottom of muffler and there is equal clearance between the frame and drive-shaft (see **Figure 6**).

9. Two (2) tailpipe options are available to provide either right-side (passenger) or left-side (driver) exit. Refer to the appropriate installation steps for your configuration.

10. Route the upper tailpipe into the muffler outlet. Depending on the storage box configuration, the upper tailpipe may need to be trimmed. Align the lower tailpipe along side the upper tailpipe until it is level and 1/2 to 2 inches below the bottom of the storage boxes. Be sure there is a minimum of 8" between the tip and ground. Mark the location of the upper tailpipe at the bottom of the swedge (see **Figure 7**). Trim the upper tailpipe.

11. Place a 3.5" saddle clamp on the lower tailpipe and assemble the lower tailpipe to the upper tailpipe. Snug the 3.5" clamp.

Figure 6 Left exit shown

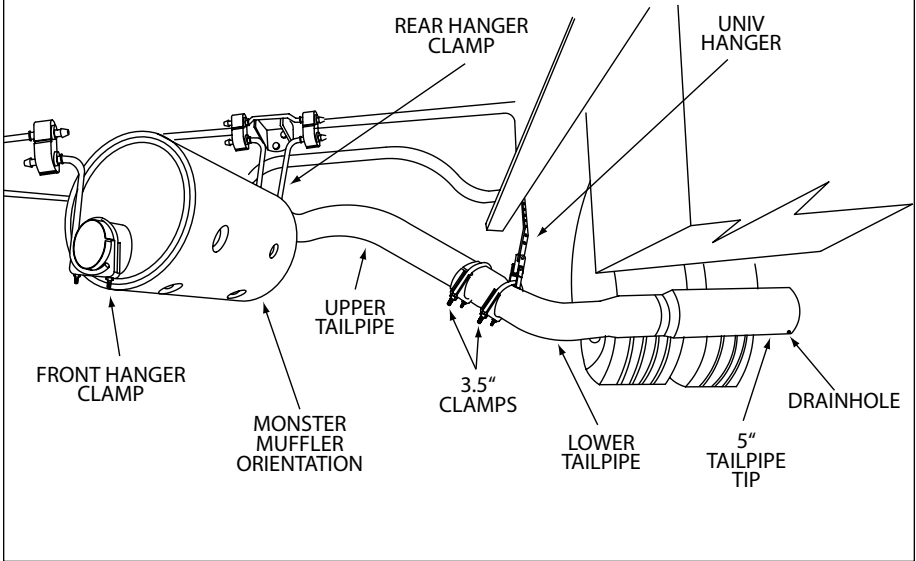
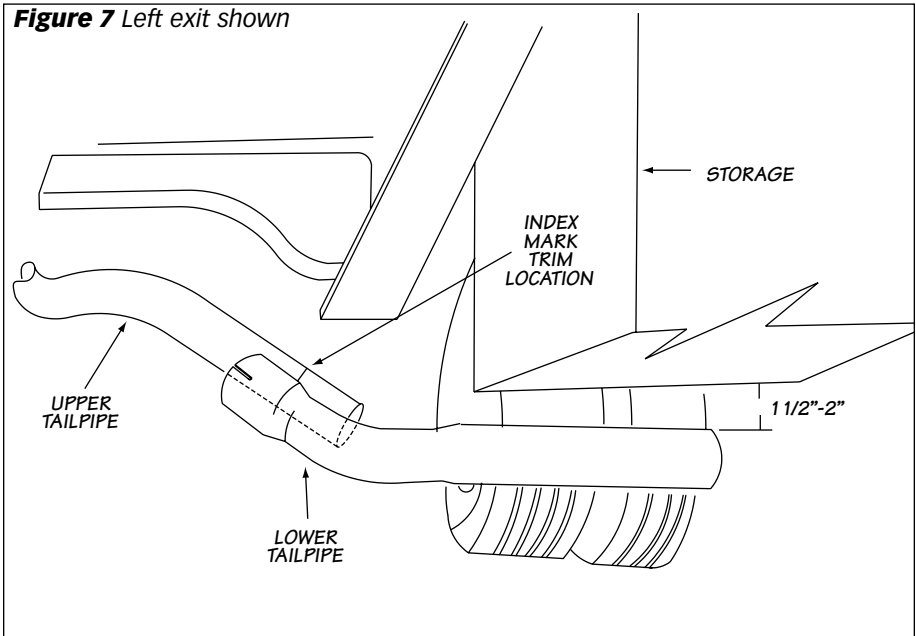

Figure 7 Left exit shown



12. Attach a 3.5" clamp to the universal hanger. Put the universal hanger onto the tailpipe. For the universal hanger, find a suitable hole in the frame rail directly over the tailpipe. Using the $\frac{3}{8}$ " hardware, support the universal hanger and tailpipe assembly level to the storage boxes.

13. Install the 5" dual wall tip onto the tailpipe outlet. Adjust the tip such that is a minimum of a 1-inch below the storage boxes. Be sure drainhole is facing down.

14. With the exhaust positioned properly, begin to tighten the clamps starting with the ones closest to the front of the vehicle and working your way back. Torque the $\frac{3}{8}$ " hardware and exhaust clamps evenly to 35 ft-lbs. Make sure that each slip is fully inserted (+/- $\frac{1}{4}$ "). All hanger pins should be facing forward (see **Figure 8**). Remove

the protective covering from the tailpipe tip.

CAUTION: The protective covering may ignite and burn if not removed prior to running the engine.

15. Your system includes two (2) Banks Power logos that can be placed on the front passenger and driverside panels in front of the front tires.

16. Re-connect negative battery cable(s). Start the engine and listen for exhaust leaks. Tighten the exhaust clamps as necessary. Whenever possible, tack-welding slip connections to prevent disengagement is recommended.

-END, SECTION 2-

Figure 8

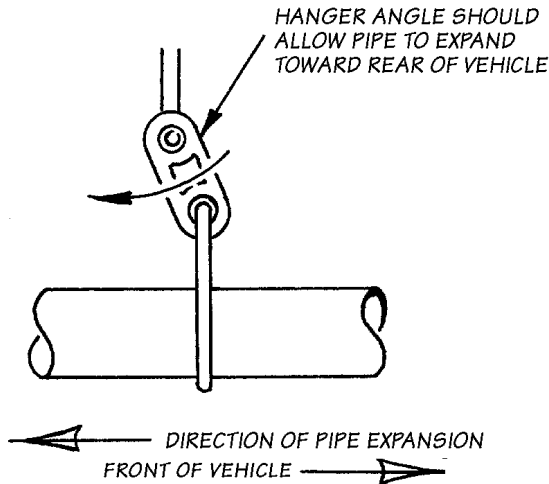

Section 3

RAM AIR FILTER INSTALL

1. Locate the engine air filter box by lifting the hood on the front of the motorhome. Remove the cover by releasing the four (4) clips on the sides of the housing and slide the cover toward the front of the motorhome.

2. Remove the old air filter element from the filter housing and replace it with the Banks Ram-Air filter element. Place the Banks filter element in the right orientation and check the filter seal is seating properly around the

housing to ensure no leakage. For proper maintenance and service on the Banks Ram-Air Filter, refer to **CLEANING AND OILING THE BANKS RAM-AIR FILTER.**

3. Slide the tabs on the cover into the slots on the air filter box. Press the cover down gently and re-attach the four (4) clips on the side to securely clamp the cover.

-END, SECTION 3-

Section 4

CLEANING AND OILING THE BANKS RAM-AIR FILTER

Notification

The Banks Ram-Air Filter comes pre-oiled and no oiling is necessary for initial installation.

Use Banks Ram-Air Filter cleaning system (part #90094), available from Gale Banks Engineering to service the Air Filter. Follow the instructions included with the cleaning system to clean and re-oil your Banks Ram-Air Filter.

1. PRE-CLEANING

Tap the element to dislodge any large embedded dirt, then gently brush with a soft bristle brush. *NOTE: If complete cleaning is not practical at this time, recoil the element and reinstall in your vehicle.*

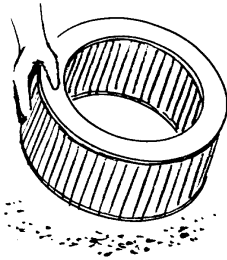

2. SPRAY-ON CLEANING

Spray Air-filter cleaner liberally onto the entire element and let soak for 10 minutes.

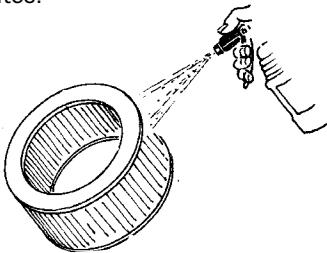

PAN CLEANING

Large air-filter elements can be rolled or soaked in a shallow pan of Air-filter cleaner. Remove immediately and let soak for approximately 10 minutes.

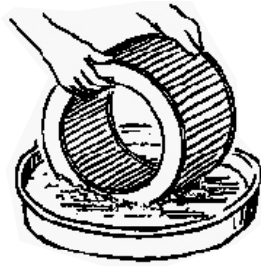

3. CLEANING HINTS

Use only Air-filter cleaner. No gasoline cleaning, No steam cleaning, No caustic cleaning solutions, No strong detergents, No high-pressure car wash, No parts cleaning solvents. Any of these No's can cause harm to the cotton filter media plus SHRINK and HARDEN the rubber end caps.

4. RINSE OFF

Rinse off the element with low-pressure water. Tap water is okay. Always flush from the clean side to dirty side. This removes the dirt and does not drive it into the filter.

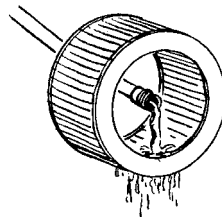

5. DRYING HINTS

Always dry naturally. After rinsing, shake off all excess water and let the element dry naturally. **DO NOT USE COMPRESSED AIR – DO NOT USE OPEN FLAME – DO NOT USE HEAT DRYERS!**

EXCESS HEAT WILL SHRINK THE COTTON FILTER MEDIA. COMPRESSED AIR WILL BLOW HOLES IN THE ELEMENT.

6. AEROSOL OILING

After cleaning air filter always reoil before using. Spray Banks Ram-Air filter oil down into each pleat with one pass per pleat. Wait 10 minutes and re-oil any white spots still showing.

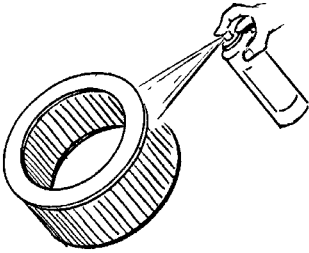

7. OILING HINTS

Never use a Banks Ram-Air filter without oil (the filter will not stop the dirt without the oil). Use only Banks Ram-Air filter oil. Air-filter oil is a compound of mineral and animal oil blended with special polymers to form a very efficient tack barrier. Red dye is added to show just where you have applied the oil. Eventually the red color will fade but the oil will remain and filter the air. **NEVER USE Automatic Transmission Fluid. NEVER USE Motor Oil. NEVER USE Diesel Fuel. NEVER USE WD40, LPS, or other light-weight oils.**

8. REINSTALL

Reinstall your Banks Ram-Air filter element with proper care. Make sure the element seats properly in the filter case. Install the cover making sure it's in the right position. Tighten all the nuts, bolts, screws or clips to factory specifications.

9. DO NOT DISCARD

Affix the "Do Not Discard" sticker to the filter case (included with every Banks replacement element). Make sure you put the sticker in a highly visible place to alert your mechanic not to discard.

10. PERFORMANCE HINTS

Service every 50-100,000 miles on street-driven applications. Service more often in offroad or heavy-dust conditions. If an air-filter restriction gauge is installed, then change the element when the air-filter restriction reaches 18"-H.O.

CAUTION! Extremely fine dust from agriculture or offroad use will pull the oil from the element. Frequent reoiling of the element's clean side might be required. Completely service when practicable. For extra protection use an air-filter sealing grease on rubber ends of the element. Service only with Air-filter cleaner and Air-filter oil.

-END, SECTION 4-

Bill of Materials See General Assembly on page 5

Item #	Description	Qty	P/N
1a	Left TorqueTube (For 2006-2010 Models)	1	53009
1b	Left Torquetube (For 2011 Models)	1	53014
2a	Right TorqueTube (For 2006-2010 Models)	1	53010
2b	Right TorqueTube (For 2011 Models)	1	53015
3	TorqueTube Gaskets	2	93087
4	Starter Heatshield	1	26085
5	#52 Hose Clamp	1	92853
6	Valve Cover Heatshield	1	26301
7	Conical Seals	2	93161
8a	Y-pipe Assy (For 2006-2010 Models)	1	53011
8b	Y-pipe Assy (For 2011 Models)	1	53018
9a	Y-pipe Extension (For 2006-2010 Models)	1	53012
9b	Y-pipe Extension (For 2011 Models)	1	53019
10	Y-pipe Gasket	1	93164
11	Factory Studplate, Nuts (not supplied)	2	
12	Factory Cat Converter (not supplied)	1	
13	O2 Sensor Extension (For 2006-2010 Models)	2	62200
14	Intermeditate Pipe	1	52961
15	Interm Pipe, w/ Heatshield	1	53120
16	Front Hanger Clamp	1	52963
17	Muffler, 3" in/ 3.5"out	1	52405
18	Rear Hanger Clamp	1	52964
19(a)	Upper Tailpipe, left exit	1	52965
19(b)	Upper Tailpipe, right exit	1	52967
20	Lower Tailpipe	1	52966
21	Tailpipe Tip 5" Dual Wall	1	52384
22	3" Saddle Clamp	2	52465
23	3.5" Saddle Clamp	2	52468
24	Universal Hanger	1	52193
25	Nut, 3/8" crimplock	1	91416
26	Washer, 3/8" USS	6	91403
27	Bolt, 3/8"-16x1"	1	91427
28	Bolt, 3/8"-16x1.75"	4	91430
29	Bolt, 8mm-1.25x30mm	20	91811
30	Banks Urocals	2	96009
31	Zip ties	20	62001
32	Heat Shield Blankets 6"x 7"	3	26000
33	Heat Shield Blankets 6"x 14"	3	26001
34	Steel Wire Ties	6	26013
35	2.5" Saddle Clamp	1	52461

Learn more about performance exhaust systems we have.