

MANUAL

**WITH INSTALLATION
INSTRUCTIONS**

banks

STINGER

S Y S T E M

FORD 460 EFI ENGINE

1987-96 STANDARD CAB PICKUPS

THIS MANUAL IS FOR USE WITH SYSTEMS 49207, 49250 and 49253

1987-96 EXTENDED/CREW CAB PICKUPS

THIS MANUAL IS FOR USE WITH SYSTEMS 49218, 49252 and 49254

banks

BANKS STINGER® SYSTEM FORD 460 EFI TRUCK

Dear Customer:

Your new Banks Stinger is a unique combination of air intake and exhaust components designed to make the most of your engine's power potential. By removing intake and exhaust restrictions, providing cooler intake air, and tuning the exhaust to create a scavenging effect, your engine can produce more power at a higher level of efficiency. If your driving habits remain the same, your fuel mileage should go up, and you can run on the same octane fuel you are accustomed to using.

GENERAL INSTALLATION PRACTICES

1. For ease of installation and trouble-free operation of your Banks Stinger® System, please read this entire 8-page owner's manual before starting any work. (If any pages are missing from this package, please call GALE BANKS ENGINEERING immediately for a replacement.) Become thoroughly familiar with all components & phases of the installation & determine what additional tools or materials you may need to complete the installation.

2. Any time the vehicle is raised off its wheels, it should be supported by jack stands or ramps of adequate capacity for the vehicle's weight. NEVER PERFORM ANY WORK UNDER A VEHICLE SUPPORTED ONLY BY ITS SERVICE JACK OR A HYDRAULIC JACK.

NOTIFICATION

The Banks Ram-Air Filter comes pre-oiled and no oiling is necessary for initial installation. Service the filter as specified in the Cleaning and Oiling the Banks Ram-Air Filter Section of this manual.

FIGURE 1

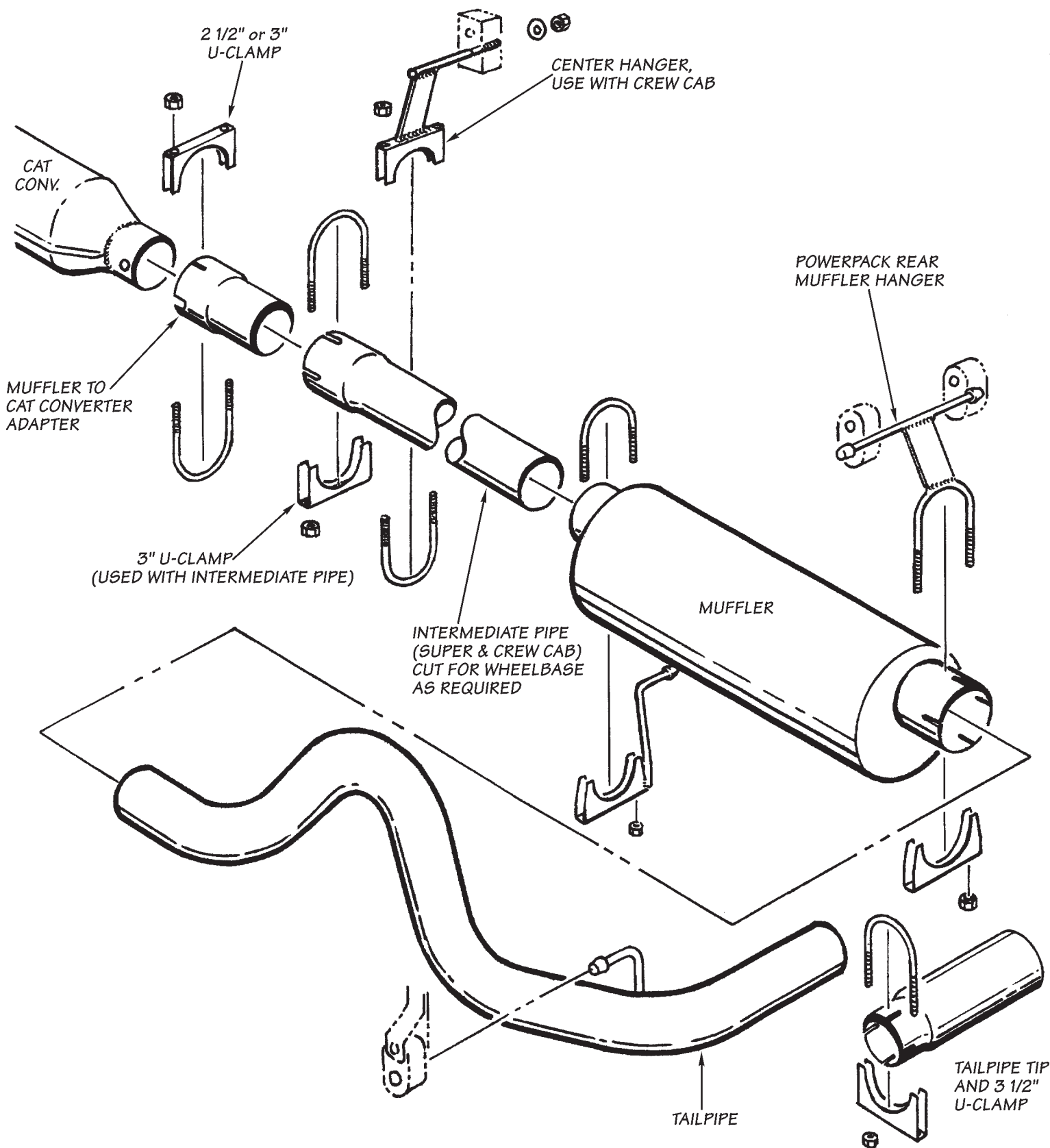

INSTALLATION INSTRUCTIONS

1. Raise vehicle. See safety precautions, page 2. If possible, support vehicle from chassis and allow rear axle to hang.

2. Remove muffler and tailpipes from over rear axle. If this assembly is to be saved intact, the vehicle must be raised high enough so the muffler/tailpipe can be lifted over the axle. If the tailpipes are not to be saved, cutting the pipes will allow the assembly to be removed more quickly.

To remove the exhaust piping from the hangers, squirt some WD40 or similar lubricant onto the lower end of the rubber hangers where the hanger rod protrudes through the rubber. Now use a pry bar to pop the rubber hangers off the rod.

3. Remove the intermediate pipe from between the muffler and catalytic converter. This will be a short stub adapter on short wheelbase models, or a pipe or pipe with hanger on longer wheelbase vehicles.

4. Install the converter-to-muffler adapter onto the catalytic converter outlet. Install a 3 x 3" adapter on converters with a 3" outlet, or a 2½" x 3" adapter on converters with a 2½" outlet. When the adapter is in place, install a 2½" or 3" exhaust U-clip to secure the adapter.

5. If the vehicle is a Standard Cab (not Super Cab or Crew Cab) model, install a catalytic-converter outlet adapter on the catalytic converter. Install a 3 x 3" adapter on converters with a 3" outlet, or a 2½ x 3" adapter on converters with a 2½" outlet. **See Figure 1.**

6. If the vehicle is anything other than the Standard Cab 133" wheelbase model, an extension pipe must be used between the catalytic converter and the muffler. Vehicles with catalytic converters having a 2½" converter outlet will require the 2½ x 3" adapter and the extension pipe. Most applications require that the extension pipe be cut to a specific length. The following chart lists the extension pipe and adapter requirements for the various cab/chassis applications.

7. Crew Cab models use an additional hanger to support the center of the extension pipe. A 3" clamp/hanger is supplied with the 41" extension pipe.

Cab/Chassis	Cat. Conv. Outlet Size	Pipe/Adapter	Modification
Std. Cab/Long Bed 133" wheelbase	3" dia.	3 x 3" Adapter	None
Std. Cab/Long Bed 133" wheelbase	2½" dia.	2½ x 3" Adapter	None
Super Cab/Long Bed 155" wheelbase	3" dia.	Extension Pipe	Cut off 13"
Super Cab/Long Bed 155" wheelbase	2½" dia.	Extension Pipe/ 2½ x 3" Adapter	Cut off 16"
Super Cab/Short Bed 139" wheelbase	3" dia.	Extension Pipe	Cut off 29"
Crew Cab/Long Bed 168" wheelbase	3" dia.	Extension Pipe	None
Crew Cab/Long Bed 168" wheelbase	2½" dia.	Extension Pipe/ 2½ x 3" Adapter	Cut off 3"
Crew Cab/Short Bed 152" wheelbase	3" dia.	Extension Pipe	Cut off 16"

Install this hanger clamp into the factory rubber hanger to support the pipe. Do not tighten at this time.

8. Install the muffler onto the catalytic converter or intermediate pipe. Hang the muffler by the front and rear hanger clamps in the factory rubber hangers. Leave clamps loose enough for adjustment.

9. Install the Stinger tailpipe over the axle and into the muffler outlet. Insert the pin on the tailpipe into the original factory rubber hanger.

10. Check the alignment of the muffler and tailpipe. Make sure tailpipe has adequate clearance to all chassis and suspension components (¾" minimum) to prevent rattles. When alignment looks good, tighten all clamps.

11. Lower the vehicle. Remove the plastic silencer from the engine air inlet hoses between the air cleaner housing and the throttle body.

12. Using a hacksaw, remove the tapered portions of the silencer by sawing as shown in **Figure 2**. Remove any plastic shavings after cuts are completed. Reinstall the modified silencer in the inlet air hoses.

13. Replace the original paper element type air filter with the low restriction reusable K&N filter provided. Make sure the filter is seated in the housing. See the filter service section of these instructions for filter maintenance and care.

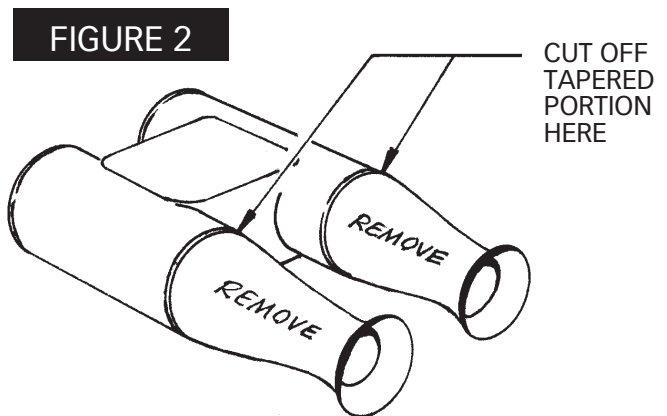

14. Install new Banks Ram-Air filter cover using four 6mm x 40mm metric hex bolts. Tighten bolts just enough for cover feet to contact housing base. Do not overtighten, as this can distort cover and base. Reinstall hoses and tighten clamps.

NOTE: All 1996 California-Only systems (P.N. 49253 & 49254) reinstall factory air filter cover.

15. Test drive the vehicle. Listen for any exhaust leaks and rattles. Correct leaks and rattles by tightening or repositioning exhaust piping as required. **NOTE:** The exhaust system may smoke somewhat at first as the grease used in the tube bending process burns off the pipes.

CLEANING AND OILING THE BANKS RAM-AIR FILTER

NOTIFICATION

The Banks Ram-Air Filter comes pre-oiled and no oiling is necessary for initial installation. Use Banks Ram-Air Filter cleaning system (part #90094), available from Gale Banks Engineering to service the Air Filter. Follow the instructions included with the cleaning system to clean and re-oil your Banks Ram-Air Filter.

1. PRE-CLEANING

Tap the element to dislodge any large embedded dirt, then gently brush with a soft bristle brush. *NOTE: If complete cleaning is not practical at this time, reoil the element and reinstall in your vehicle.*

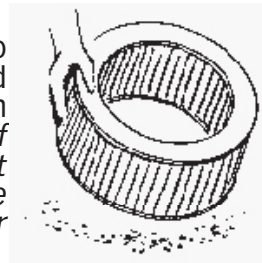

2. SPRAY-ON CLEANING

Spray air-filter cleaner liberally onto the entire element and let soak for 10 minutes.

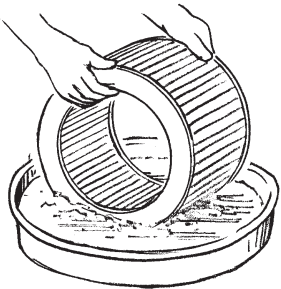
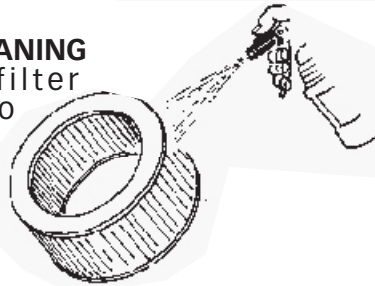

PAN CLEANING

Large air-filter elements can be rolled or soaked in a shallow pan of air-filter cleaner. Remove immediately and let soak for approximately 10 minutes.

3. CLEANING HINTS

Use only air-filter cleaner. NO gasoline cleaning, NO steam cleaning, NO caustic cleaning solutions, NO strong detergents, NO high-pressure car wash, NO parts cleaning solvents. Any of these NOs can cause harm to the cotton filter media plus SHRINK and HARDEN the rubber end caps.

RINSE OFF

Rinse off the element with low-pressure water. Tap water is okay. Always flush from the clean side to dirty side. This removes the dirt and does not drive it in to the filter.

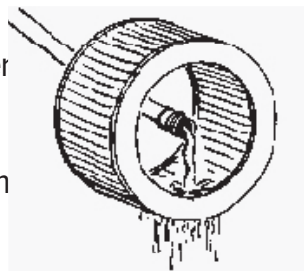

5. DRYING HINTS

Always dry naturally. After rinsing, shake off all excess water and let the element dry naturally. DO NOT USE COMPRESSED AIR – DO NOT USE OPEN FLAME – DO NOT USE HEAT DRYERS! EXCESS HEAT WILL SHRINK THE COTTON FILTER MEDIA. COMPRESSED AIR WILL BLOW HOLES IN THE ELEMENT.

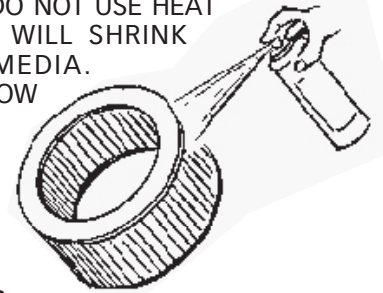

6. AEROSOL OILING

After cleaning air filter always reoil before using. Spray Banks Ram-Air filter oil down into each pleat with one pass per pleat. Wait 10 minutes and re-oil any white spots still showing.

7. OILING HINTS

Never use a Banks Ram-Air filter without oil (the filter will not stop the dirt without the oil). Use only Banks Ram-Air filter oil. air-filter oil is a compound of mineral and animal oil blended with special polymers to form a very efficient tack barrier. Red dye is added to show just where you have applied the oil. Eventually the red color will fade but the oil will remain and filter the air. NEVER USE Automatic Transmission Fluid. NEVER USE Motor Oil. NEVER USE Diesel Fuel. NEVER USE WD40, LPS, or other light-weight oils.

8. REINSTALL

Reinstall your Banks Ram-Air filter element with proper care. Make sure the element seats properly in the filter case. Install the cover making sure it's in the right position. Tighten all the nuts, bolts, screws or clips to factory specifications.

9. DO NOT DISCARD

Affix the "Do Not Discard" sticker to the filter case (included with every Banks replacement element). Make sure you put the sticker in a highly visible place to alert your mechanic not to discard.

10. PERFORMANCE HINTS

Service every 50-100,000 miles on street-driven applications. Service more often in offroad or heavy-dust conditions. If an air-filter restriction gauge is installed, then change the element when the air-filter restriction reaches 18"/H₂O.

CAUTION! Extremely fine dust from agriculture or offroad use will pull the oil from the element. Frequent reoiling of the element's clean side might be required. Completely service when practicable. For extra protection use an air-filter sealing grease on rubber ends of the element. Service only with air-filter cleaner and air-filter oil.

PARTS LIST

Banks Stinger System Ford 460 EFI Engine Std./Ext./Crew Cab Pickups

QTY.	DESCRIPTION	1987-93	1987-93	1993-96	1993-96	1996	1996
		Std. Cab PART#	Ext./Crew Cab PART#	Std. Cab PART# (*96 Excludes CA)	Ext./Crew Cab PART# (*96 Excludes CA)	Std. Cab PART# (CA Only)	Ext./Crew Cab PART# (CA Only)
1	ADAPTER, Cat. Conv. to Muffler	52601	52601	52604	52604	52604	52604
4	BOLT, 6mm x 1.00 x 40mm	91760	91760	91760	91760	•	•
1	CARD, Product Registration	96392	96392	96392	96392	96392	96392
1	CLAMP, Exhaust, 2½"	52461	52461	•	•	•	•
1	CLAMP, Exhaust, 3"	•	52465	52465	52465	52465	52465
1	CLAMP, Exhaust, 3½"	52467	52467	52467	52467	52467	52467
1	CLAMP, Hanger, 3"	52288	52288	52288	52288	52288	52288
1	CLAMP, Hanger, 3½"	52696	52696	52696	52696	52696	52696
1	CLAMP, Hanger, 3" w/Rod	•	•	•	52689	•	52689
1	CLAMP, Hanger, Rear	•	•	•	52289-00	•	52289-00
1	COVER, Banks Ram-Air	42520	42520	42520	42520	•	•
1	DECAL, Carb. "Rep. Part"	96024	96024	96024	96024	96024	96024
1	FILTER ELEMENT, Banks Ram-Air™	41508	41508	41508	41508	41508	41508
1	MUFFLER, Dynaflo™, Stainless w/heat shield.	52405	52405	52405	52405	52405	52405
1	NUT, 3/8" 16 Crimp Lock.	•	•	•	91416	•	91416
1	OWNERS MANUAL	96346	96346	96346	96346	96346	96346
1	PIPE, Intermediate	•	52289	•	52290	•	52290
1	PIPE, Tailpipe Extension, Chrome, 4 x 12"	52281	52281	52281	52281	52281	52281
1	PIPE, Monster™ Tailpipe, Stainless 3½"	52683	52683	52683	52683	52683	52683
3	PLAQUE, "Banks PowerPack"	96008	96008	96008	96008	96008	96008
1	SERVICE KIT, Air Filter	90094	90094	90094	90094	90094	90094
1	WARRANTY STATEMENT	96362	96362	96362	96362	96362	96362
1	WASHER, 3/8" SAE	•	•	•	91402	•	91402