

banks

with Installation Instructions

Manual

Banks PowerPack[®] System

Including:

Banks Stinger[®] System

1999-2004 Ford 6.8L V-10
F250/F350 Pickups and Excursions

THIS MANUAL IS FOR USE WITH SYSTEMS 49130-49139

BANKS

General Installation Practices

- 1.** For ease of installation of your Banks system, familiarize yourself with the procedure by reading the entire manual before starting work.
- 2.** The exploded views provide only general guidance. Refer to each step and section diagram in this manual for proper instruction.
- 3.** Throughout this manual, the left side of the vehicle refers to the driver's side, and the right side to the passenger's side.
- 4.** Disconnect the ground cables from the battery before beginning work. If the vehicle has more than one battery, be sure that the engine primary battery is disconnected. This is necessary for safety and to ease the installation of the passenger side TorqueTube® exhaust manifold.

5. Route and tie wires and hoses a minimum of 6 inches away from exhaust heat, moving parts and sharp edges. Clearance of 8 inches or more is recommended where possible.

6. When raising the vehicle, support it on properly weight-rated safety stands, ramps or a commercial hoist. Follow the manufacturer's safety precautions. Take care to balance the vehicle to prevent it from slipping or falling. When using ramps, be sure the front wheels are centered squarely on the topsides; put the transmission in park; set the hand brake; and place blocks behind the rear wheels. If the vehicle is supported by a hoist, the front wheels may be removed for further accessibility.

CAUTION! Do not use floor jacks to support the vehicle while working under it. Do not raise the vehicle onto concrete blocks, masonry or any other item not intended specifically for this use.

7. During installation, keep the work area clean.

Notification

The Banks Ram-Air Filter comes pre-oiled and no oiling is necessary for initial installation. Service the filter as specified in the Filter Maintenance Section of this manual.

Tools Required

- 1 1/4" wrench
- 5mm 6 point socket
- Chisel or hacksaw
- Saw or torch
- Clean shop towels or rags
- Pry bar or channel lock pliers
- 1/4" and 3/8" drive ratchets with metric sockets and a 1/4" drive extension
- Metric combination or open-end wrenches
- Standard and Phillips head screwdrivers
- Penetrating oil or light lubricant spray
- Standard and phillips head screwdrivers

Table of Contents

General Assembly	4
Section 1	6
TorqueTube Manifolds	
Section 2	10
Monster® Exhaust	
Section 3	11
Ram-Air® Intake	
Section 4	11
Filter Maintenance	
Section 5	12
OttoMind Engine Calibration Module Installation	

General Assembly

Figure 1

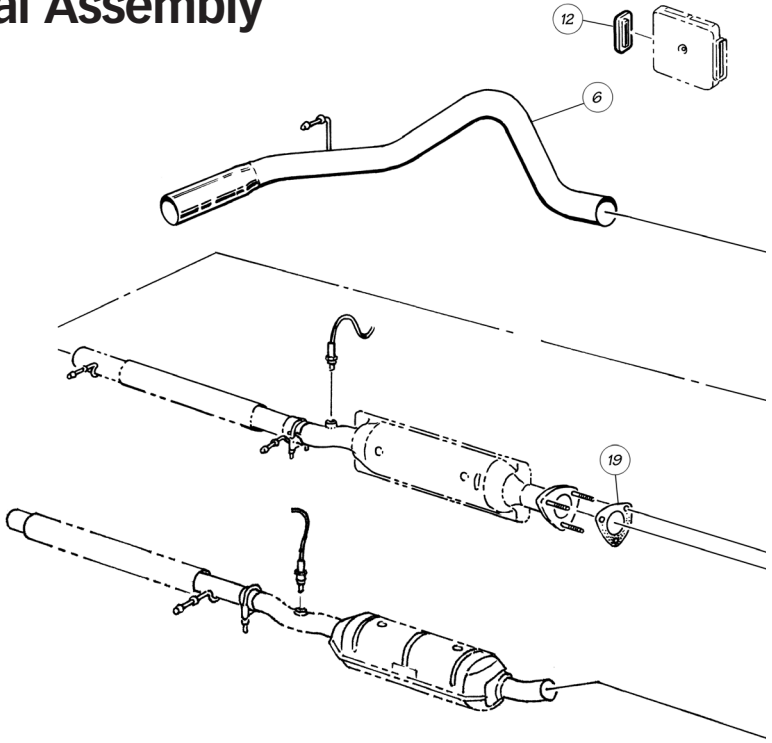

Item #	Part #	Description	QTY
1	53030	TORQUETUBE, Left	1
2	53031	TORQUETUBE, Right	1
3*	5313X	Y-PIPE	1
4	53131	Y-PIPE EXTENSION	1
5**	5243X	DYNAFLOW MUFFLER	1
6	52143	MONSTER TAILPIPE	1
7	26140	HEATSHIELD, Frame	1
8	26145	BRACKET, Heatshield	1
9	26085	HEATSHIELD, Starter	1
10	42018	AIR FILTER ELEMENT	1
11	42060	AIR FILTER HOUSING	1
12***	--	OTTOMIND	1
13	52465	CLAMP, Hanger, 3" (Excursion and crew cab models only)	1
14	52468	CLAMP, Exhaust, 3 1/2"	1
15	52461	CLAMP, Exhaust, 2 1/2"	1
16	92853	CLAMP, Hose, #52	1
17	93161	CONICAL SEAL, Exhaust Outlet	2
18	93086	GASKET, TorqueTube	2
19	93166	GASKET, Catalytic Converter (Early Pickup only)	1

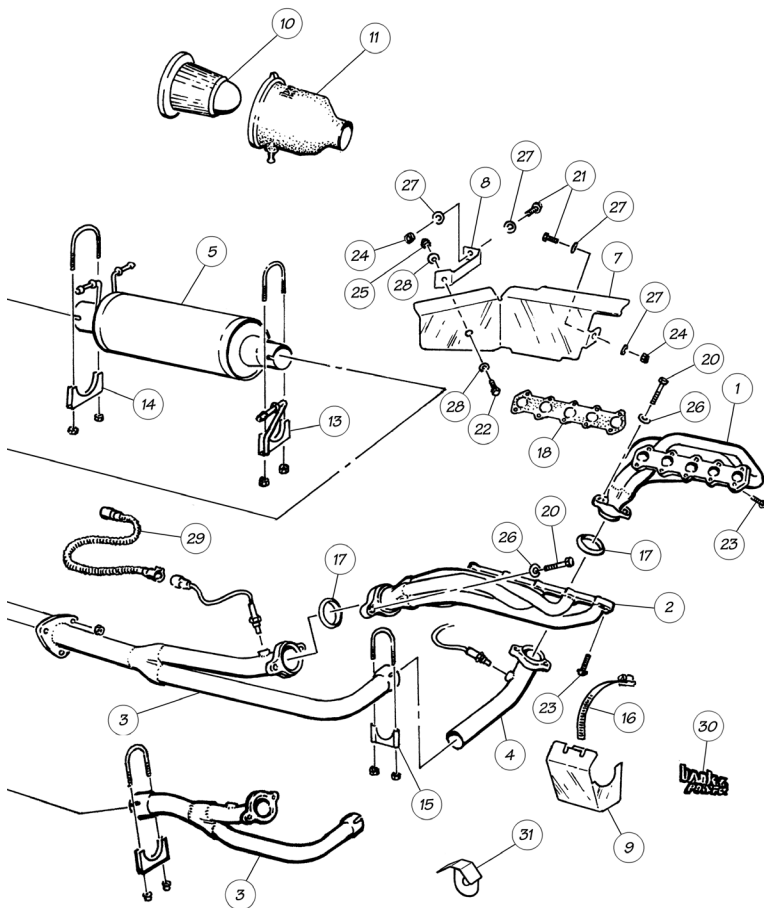

20	91430	BOLT, 3/8" 16 x 13/4" Hex	4
21	91228	BOLT, 5/16" - 18 x 1" Hex	2
22	91116	BOLT, 1/4" - 20 x 5/8" Hex	3
23	91811	BOLT, 8mm x 1.25 x 35mm	20
24	91212	NUT, 5/16" - 18 crimplock	2
25	91113	NUT, 1/4" - 20 crimplock	3
26	91402	WASHER, 3/8" SAE	4
27	91202	WASHER, 5/16" SAE	4
28	91103	WASHER, 1/4" USS	6
29	62195	WIRE EXTENSION, O ₂ Sensor	1
30	96009	UROCAL, "Banks Power"	2
31	26000	HEATSHIELD	1

* 49131-49134 & 49138 use P/N 53138, 49130, 49135 use P/N 53136

** 49134 & 49139 use P/N 52439, 49131-49132 & 49137 use P/N 52437

*** OttoMind P/N is vehicle specific

Section 1

TORQUETUBE MANIFOLDS

For Stinger installation, **proceed to step 26.**

1. Raise the vehicle using a hoist of a jack and properly rated jack stands. remove both front wheels.

2. Unbolt the front inner fender wells and remove from the vehicle. The left fender well will have various electrical connectors clipped to it that must be removed. The right fender well has a vacuum reservoir attached with three nuts. Once these components are detached from the fender wells and the fender wells themselves are removed, the components can remain in their place until the fender wells are reinstalled.

3. Locate the oxygen sensors in each exhaust headpipe, downstream of the factory exhaust manifolds. Unplug the connectors and remove both the oxygen sensors. Mark the sensors for correct reinstallation.

4. Disconnect the three-bolt flange at the front of the catalytic converter from the factory Y-pipe assembly. Disconnect the headpipes from the exhaust manifolds and remove the Y-pipe assembly from the vehicle.

5. On vehicles with EGR system: On the driver's side of the engine, unscrew the EGR tube from the exhaust manifold with a 1 $\frac{1}{4}$ " wrench and remove the EGR tube from the manifold.

6. Pull out the dipstick and remove the small bolt that attaches the oil pan dipstick tube to the cylinder head. Pull the dipstick tube up and out of the engine block. Check to see if there is an o-ring on the tube. If not, the o-ring may be stuck inside the hole in the engine block. This o-ring should be retrieved if necessary and placed back onto the tube before reinstalling it.

7. To remove the exhaust manifolds, use a wrench or socket to back the nuts away from the manifolds at least one turn, then use a 5mm 6 point socket to remove each stud from the head. As an alternate method, take the nuts off the studs, and then remove the studs.

8. After the manifolds have been removed from the vehicle, remove any remaining studs from the heads. The studs must be removed from the heads in order to install the Banks TorqueTubes.

9. Install the starter heatshield onto the starter using the #52 hose clamp provided. **See Figure 2.**

Figure 2

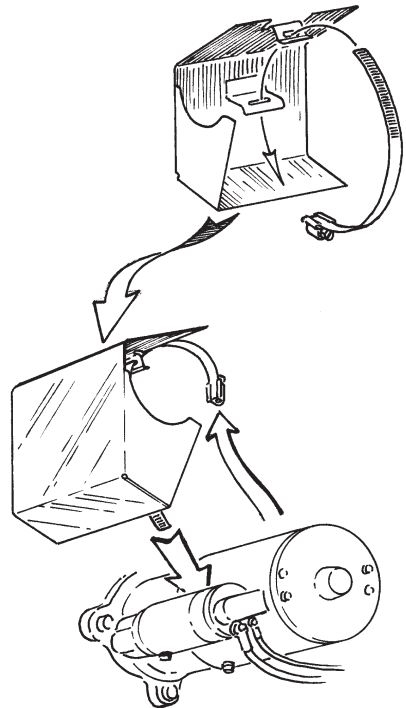

CAUTION: Make sure that the heatshield does not come in contact with the positive terminal of the starter once the heatshield is tightened down.

10. Inspect the exhaust mounting surfaces of the cylinder heads and clean away any deposits to assure proper sealing of the Banks TorqueTubes. Be careful when doing this as the cylinder heads are made from aluminum, and can be easily damaged. We recommend the use of a Scotchbrite® pad.

Note: On 2004 models, you will need to remove the rubber flap surrounding the passenger side motor mount. Using scissors, slit the flap and remove it from the motor mount.

11. Place a small amount of anti-seize on the threads of each of the supplied manifold bolts. Use the new gaskets provided when installing the TorqueTubes. Lift the Banks TorqueTube manifolds into place and install one or two bolts to hold them in position. **See Figure 1.**

12. Make sure the o-ring is on the dipstick tube, and reinstall it into the hole in the engine block. Reattach the dipstick tube bracket to the cylinder head with the original bolt.

13. If the vehicle has EGR, attach the EGR tube to the fitting in the Banks TorqueTube manifold. If necessary, loosen the fitting at the top of the EGR tube to allow the tube to be positioned properly.

14. Install the remaining bolts into the heads and torque to 18 ft-lbs. Use care to ensure that the threads of the bolts do not cross thread in the aluminum threads of the cylinder heads.

15. If additional clearance is needed between the front tube of the left manifold and the power steering

line, loosening the fitting on the power steering box and rotate the hose until at least 3 inches of clearance exists. Retighten the fitting. Install the supplied heat shield blanket over the hose and wire tie the hose away from the manifold.

For vehicle models earlier than 2000, proceed to step 19.

16. On 2000 and later vehicles, remove the factory muffler and tailpipe from the catalytic converter and intermediate pipe. Start from the rear of the rubber hangers, then remove the muffler and tailpipe. Heat the slip joints with a torch to allow them to separate, or cut through the piping. Do not cut or damage the catalytic converter outlet or intermediate pipe. Once the muffler and tailpipe have been removed, remove the catalytic converter from the vehicle. Save all hardware and hangers, as some may be reused.

Note: If you are not sure of the model year of your vehicle, check for the location of the 3-bolt converter inlet flange. If the flange is in front of the transmission crossmember, your vehicle is 2000 or later.

17. Measure and mark a point 8" back from the rear of the catalytic converter inlet flange on the top side of the catalytic converter inlet pipe. Cut through the pipe at this point square to the pipe centerline to remove the converter inlet flange leaving a section of the pipe and the hanger on the converter. **See Figure 3.** Deburr the cut pipe on the converter, then proceed to **step 20.**

18. Slip a 3" U-clamp over the outlet end of the Y-pipe, then slip the Y-pipe onto the cut inlet stub on the catalytic converter, but do not tighten the clamp. Position the catalytic converter and Y-pipe assembly in the vehicle

Figure 3

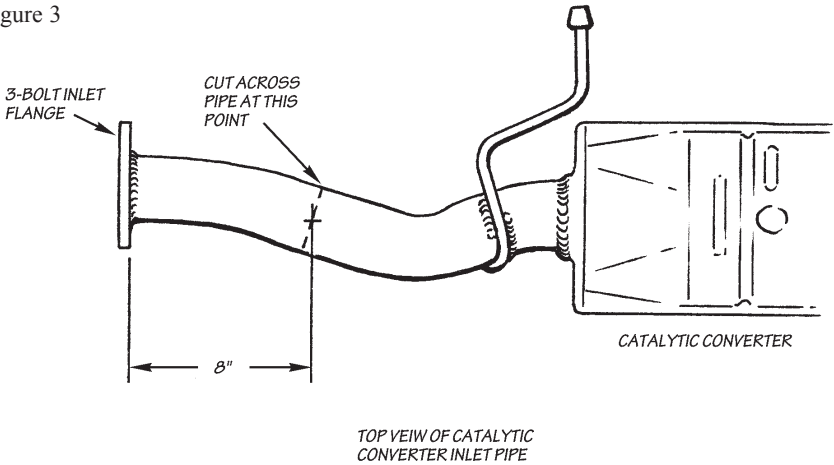

with the converter hanger pin in the rubber hanger. Place a conical seal into the flared end of the Y-pipe, and attach the Y-pipe to the right side TorqueTube manifold using the $\frac{3}{8}$ " x $1\frac{3}{4}$ " bolts and washers provided. Do not tighten the bolts yet. Proceed to **step 20**.

19. On 1999 vehicles, place the new catalytic converter flange gasket onto the studs on the catalytic converter flange. Install the Y-pipe onto the catalytic converter using the original hardware, and the pin hanger into the rubber hanger on the frame of the vehicle. Place a conical seal into the flare at the forward end of the Y-pipe, and attach the Y-pipe to the right side TorqueTube manifold using the $\frac{3}{8}$ " x $1\frac{3}{4}$ " bolts and washers provided. Do not tighten the bolts yet.

20. Slip a $2\frac{1}{2}$ " muffler clamp over the free end of the Y-pipe, and then slide the Y-pipe extension into the slip joint. With the slip joint fully seated, mark the extension pipe with a pen so that as the clamp is tightened, any slippage of the joint can be observed. Place the second conical seal onto

the flare on the extension, and attach the extension pipe to the left side TorqueTube with the $\frac{3}{8}$ " x $1\frac{3}{4}$ " bolts and washers provided. Tighten the $2\frac{1}{2}$ " clamp at the slip joint, observing the mark to be sure the joint stays fully seated as the clamp is tightened. Up to $\frac{1}{4}$ " slip is acceptable. Tighten the bolts at the manifold collectors.

Steps 21 and 22 are for 2-wheel drive vehicles only.

Steps 23-27 are for 4-wheel drive vehicles only.

21. Using the two $\frac{5}{16}$ " - 18 x 1" bolts, washers and nuts, bolt the left side heatshield and heatshield bracket to the frame. Bolt the bracket to the heatshield using the $\frac{1}{4}$ " - 20 x $\frac{5}{8}$ " bolt, washers and crimplock nut.

22. Using the blanket heatshield and wire ties provided, cover the brake line to protect it from heat.

23. Locate the vent tube from the front axle housing. Remove the retaining clip from frame at the end of the hose and pull the hose out of the crossmember. Secure the hose to the underside of the crossmember with

the 8" cable ties provided. From the outside of the frame rail, remove the bolt and captured nut from the sway bar bracket. Bolt the heatshield and heatshield bracket in place using the 5/16" - 18 x 1" bolt, washers and nylock nut at the forward tab location, 1/4" - 20 x 5/8" bolt, washers and crimplock nut and the factory bolt and captured nut in its original location.

24. On the right side of the vehicle, remove the front hub actuator line from its clip on the inside of the shock tower. Using the cable ties provided, tie the actuator line to the brake line. Using the blanket heatshield and wire ties provided, cover both the actuator and the brake line.

25. Locate the right front sway bar link. Remove the link from the vehicle by loosening the through bolts at the upper and lower mounting locations of the link. Save hardware for reuse in **step 27**.

Note: The upper through bolt is pressed into the link.

26. Remove the upper bolt from the link using a light press or similar device. Install the supplied heatshield between the bolt head and stock heatshield. Reinstall the upper bolt into the link using a light press or similar device.

27. Reinstall the link and hand-tighten the through bolts. Orient the heatshield to shield the top of the link as shown in **Figure 4**. Tighten through bolts to 85 ft-lbs.

28. Install and tighten the oxygen sensors into the threaded bungs provided on the Y-pipe and extension. Use a small amount of anti seize on the threads of the oxygen sensors. Be careful to not get any anti-seize on the sensor elements themselves.

29. Reconnect the left side oxygen

Figure 4

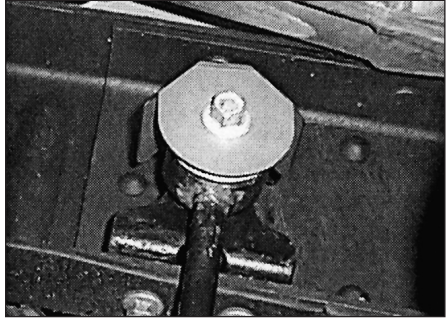

sensor to the vehicle wiring harness. On the right side an extension will be required. On the connector of the oxygen sensor and on the male connector on the sensor extension lead, remove the two index pins on the connector shell, by cutting or filing. Be careful not to damage the locking mechanism of the connectors. See **Figure 5**. Plug the oxygen sensor lead into the extension and the extension into the vehicle wiring harness. Secure the leads away from any pipes or moving linkages with the cable ties provided.

30. Reinstall the front inner fender wells. Be sure to reattach the vacuum reservoir and all the wiring clips previously removed. Reinstall the front wheels.

-END, SECTION 1-

Figure 5

REMOVE INDEX PINS
FROM PLUGS

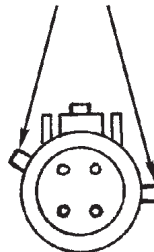

Section 2

MONSTER® EXHAUST

DO NOT CUT FACTORY INTERMEDIATE PIPE AS IT WILL BE REUSED

31. Disconnect and remove the factory tailpipe and muffler from the rear of the catalytic converter. Start from the rear and work forward, prying the pins from the rubber hangers, removing the tailpipe, then the muffler. If the slip joints will not come apart, use a torch to heat the connections until they separate, or cut the pipes apart with a saw or torch. If cutting the pipe from the rear of the catalytic converter, be careful to not cut the catalytic converter portion of the pipe. Save all hardware and hangers as some items will be reused in the PowerPack installation.

32. Using a chisel or hacksaw, remove the locating tab from the intermediate pipe.

33. On Excursions only: To allow for a proper fit, the factory muffler heatshield on the vehicle crossmember may need to be removed or trimmed. Unbolt the heatshield and the hanger assembly to remove the entire heatshield and heatshield bracket. Reinstall the factory muffler hanger bracket.

34. For Crew Cab installation: Remove the hanger located near the front of the muffler by unbolting it from the frame. Reinstall this hanger approximately 18" forward of its previous position, in the two available holes on the frame rail. Insert the pin of the 3" hanger clamp provided into the rubber hanger. Slide the Dynaflow muffler into place aligning the notch in the muffler with the pin on the Factory intermediate pipe. Lightly tighten the hanger clamp.

For Standard Cab and Extended Cab installations: Remove the hanger located near the front of the muffler by unbolting it from the frame. Because the location of the Banks Dynaflow muffler will be slightly forward from the factory muffler position, this hanger will not be reused. Slip a 3"

exhaust clamp over the inlet of the muffler and slide the muffler into place on the end of the Factory intermediate pipe.

For Excursion installation: Slip the inlet of the muffler onto the factory intermediate pipe. Install the hanger clamp into the rubber hanger on the vehicle and lightly tighten the clamp.

35. Slip the 3½" exhaust clamp over the outlet of the muffler. Install the Monster tailpipe up and over the axle and insert it into the muffler outlet. Insert the tailpipe hanger pins into the rubber hangers. Position the tailpipe and muffler such that the hangers are level with the ground and are hung slightly forward. See **Figure 6**. Once the muffler and tailpipe are properly positioned, tighten all the clamps to 35 ft-lbs. Torque ¾" hardware to 35 ft-lbs, 5/16" hardware to 20 ft-lbs, and ¼" hardware to 10 ft-lbs.

36. Lower the vehicle and reconnect the battery cables. Start the engine and listen for any exhaust leaks. Tighten bolts or clamps to correct any leaks or make adjustment as required. It is recommended that tack welds be placed on all slip connections to prevent slippage.

Note: The vehicle exhaust may smoke upon initial start-up. This is normal, as grease used in the tube-bending process burns out of the pipes.

-END, SECTION 2-

Figure 6

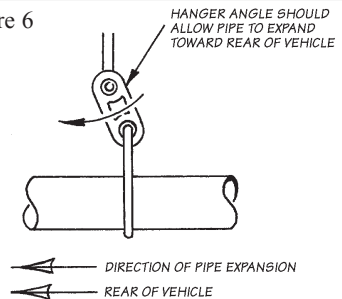

Section 3

RAM-AIR® INTAKE

37. Unlatch the clamp that holds the two halves of the air filter housing together and remove the original filter. Remove the forward half of the housing by pulling the housing up so that the feet disengage from the rubber mounting grommets.

38. Place the Banks Ram-Air filter element into the forward half of the

filter housing. Install the housing into its original location. Make sure that the mounting feet fully engage the rubber grommets. Lubricate the grommets with WD-40 or similar product, as the fit of the filter housing may be quite snug. Reassemble the housing making sure the two halves are properly seated together and latch the clamp.

-END, SECTION 3-

Section 4

FILTER MAINTANCE

Notification

The Banks Ram-Air Filter comes pre-oiled and no oiling is necessary for initial installation. Service the filter as specified in this Section of the manual.

39. Service Banks Ram Air Filter every 50-100,000 miles on street-driven applications. Service more often in off-road or heavy-dust conditions. If an air-filter restriction gauge is installed, then clean the element when the air-filter restriction gauge enters the restrictive red zone. See **Figure 7**.

40. Use Banks Ram Air Filter cleaning system (part # 90094), available from Gale Banks Engineering to service the Air Filter. Follow the instructions included with the cleaning system to clean and re-oil your Banks Ram

Air Filter. No gasoline cleaning, No steam cleaning, No caustic cleaning solutions, No strong detergents, No high pressure car wash, No parts cleaning solvents. Any of these No's can cause harm to the cotton filter media plus SHRINK and HARDEN the rubber end caps.

CAUTION! Extremely fine dust from agriculture or off-road use will pull the oil from the element. Frequent re-oiling of the element's clean side might be required. Completely service when practicable. For extra protection use an air-filter sealing grease on rubber ends of the element. Service only with Banks Ram-Air-filter cleaner and Banks Ram-Air-filter oil.

-END, SECTION 4-

Figure 7 Typical air-filter restriction gauge

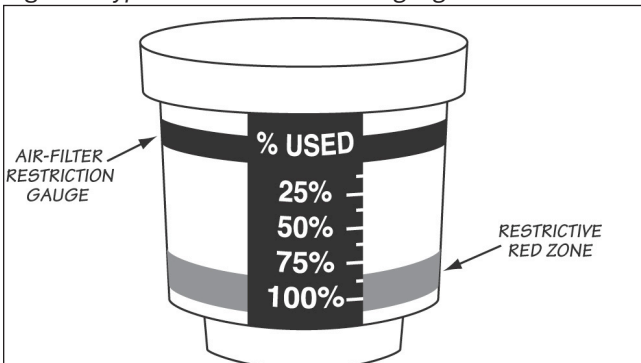

Section 5

OTTOMIND ENGINE CALIBRATION MODULE INSTALLATION

41. Be certain battery ground cables have been disconnected.

42. Locate the engine control unit (ECU) under the dash toward the left-hand side of the vehicle. It will be housed in a black plastic box bolted to the side of the vehicle. Loosen the bolt attaching the electrical connector to the ECU on the engine compartment side. This will be the connector closest to the left front fender.

43. Loosen the two 7mm hex bolts on the rear portion of the black plastic box. Remove the box and ECU from the vehicle together. Pull the ECU out of the plastic box.

44. Note the code printed on the plastic cap on the back of the ECU. This code should compare to the code printed on the Banks OttoMind® box label. Pry the plastic cap from the rear of the ECU using a small screwdriver, exposing the printed circuit board edge connector inside. Retain the plastic cap. The connector will be coated with grease and a clear silicone type coating which must be completely removed before installing the Banks OttoMind engine calibration module.

45. Using a 5.5mm nut driver, loosen and remove the six bolts that hold the case of the ECU together. Open the case of the ECU, being careful not to lose the plastic spacer or damage any circuitry inside the ECU.

46. Clean BOTH sides of the connector. First, clean the white grease off with a tissue. Next, scrape the clear silicone type coating from the connector fingers with the abrasive square provided. It is very important to clean both sides of the board in order to have a good connection between the ECU and the Banks OttoMind

module. It is only necessary to clean the connector fingers. Be careful not to damage any circuit traces on the board further inside the ECU.

47. Orient the module so that its edges line up with the edges of the ECU case. If the edges do not line up, the module is rotated 180 degrees off. Place the OttoMind module over the connector, and press firmly to set the connection. **DO NOT FORCE** the OttoMind onto the connector, as damage may result to either the ECU or the module. If the module does not install with firm pressure, check the orientation and try again.

48. Using a band saw or hack saw cut a portion of the black plastic case away allowing the OttoMind to reside in its proper location. See **Figure 8**. Reinstall the ECU with the black plastic box, making sure the ground tab is still in place at the lower mounting point. Reattach the wiring harness to the ECU and tighten the retaining bolt. Reconnect the batteries.

49. Check the operation of the OttoMind and ECU. The vehicle may not start if the coating on the ECU connector is not completely removed or if there is a mismatch of codes. A quick indication of module connections that are not cleaned properly is that the "Wait to Start" indicator will fail to light and the "Check Engine" warning indicator will stay lit after the key is switched on. If the engine fails to start, re-clean the ECU connector, reinstall the module and try again. If the problem persists, contact customer service at Gale Banks Engineering to confirm that the ECU and OttoMind codes match.

-END, SECTION 5-

Figure 8

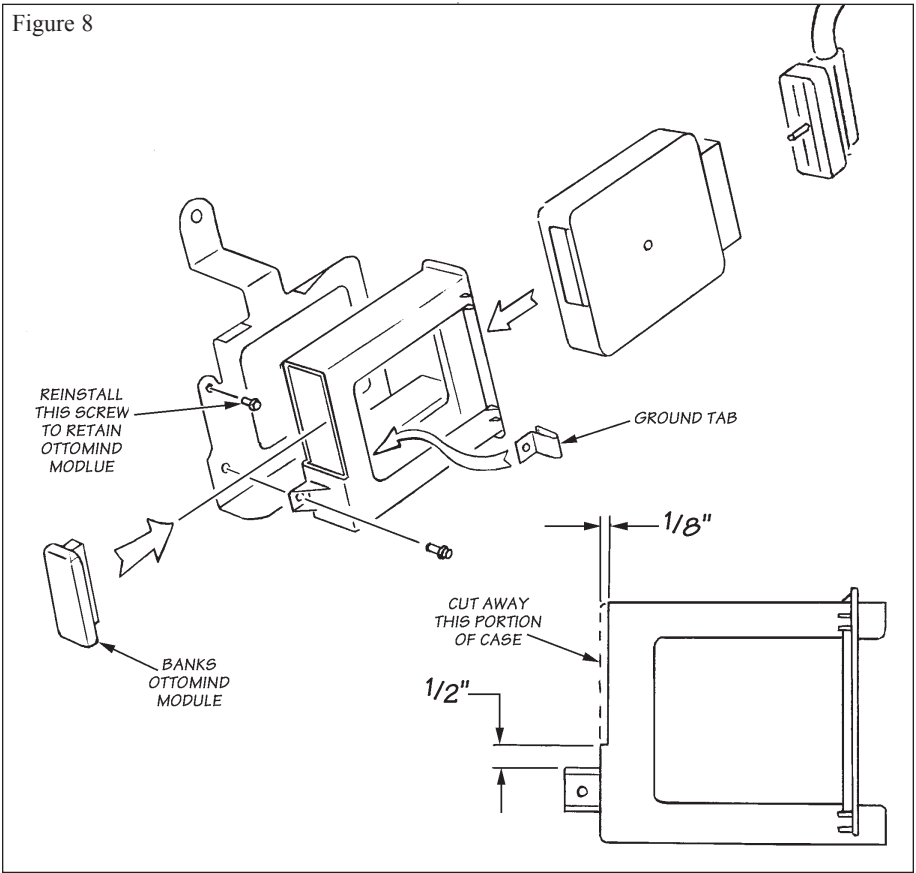

Figure 9

TYPICAL LEFT FENDER



.75



TYPICAL RIGHT FENDER



.75

