

**banks**

with Installation Instructions  
**Owner's Manual**

**Banks Monster<sup>®</sup>  
Exhaust 5" System**

**2017-2019 Chevy/GMC 6.6L L5P Duramax**

THIS MANUAL IS FOR USE WITH SYSTEM 48996, 48996-B  
DCLB, CCSB, CCLB, INCLUDING DUALY MODELS

**banks**

# General Installation Practices

1. Before starting work, familiarize yourself with the installation procedure by reading all of the instructions.
2. The exploded view (**Figure 2**) provides only general guidance. Refer to each step and section diagram in this manual for proper instruction.
3. Throughout this manual, the left side of the vehicle refers to the driver's side, and the right side to the passenger's side.
4. Disconnect the negative (ground) cable from the battery (or batteries, if there are two) before beginning work.
5. Route and tie wires and hoses a minimum of 6" away from exhaust heat, moving parts and sharp edges. Clearance of 8" or more is recommended where possible.
6. When raising the vehicle, support it on properly weight-rated safety stands, ramps or a commercial hoist. Follow the manufacturer's safety

precautions. Take care to balance the vehicle to prevent it from slipping or falling. When using ramps, be sure the front wheels are centered squarely on the topsides; put the transmission in park; set the hand brake; and place blocks behind the rear wheels.

**CAUTION! Do not use floor jacks to support the vehicle while working under it. Do not raise the vehicle onto concrete blocks, masonry or any other item not intended specifically for this use.**

7. During installation, keep the work area clean. Do not allow anything to be dropped into intake, exhaust, or lubrication system components while performing the installation, as foreign objects will cause immediate engine damage upon start-up.

## Tools Required:

- 1/2" and 3/8" drive ratchets with standard and metric sockets and 1/2" and 3/8" drive extension
- Standard and metric combination or open-end wrenches
- Standard screwdriver
- Clean shop towels or rags
- Pry-bar
- Reciprocating saw

## Highly recommended tools and supplies:

- Penetrating oil or light lubricant spray
-



## **WARNING!**

**READ AND UNDERSTAND OWNER'S MANUAL PRIOR TO USE. FAILURE TO FOLLOW WARNINGS COULD RESULT IN **SERIOUS INJURY** OR **DEATH**.**

### **NORMAL OPERATION**

Do not park, idle, or drive your vehicle on dry grass or other dry ground cover. The emission system heats up the engine compartment and exhaust system, creating a risk of fire.

The normal operating temperature of the exhaust system is very high. Never work around or attempt to repair any part of the exhaust system until it has cooled. Use special care when working around the diesel oxidation catalytic converter or diesel particulate filter. The diesel oxidation catalytic converter and the diesel particulate filter heat up to very high temperatures after only a short period of engine operation and remain hot after you switch the engine off.

Stay clear of the exhaust tailpipe after prolonged driving. Hot exhaust gasses and coming in contact with the tailpipe and/or tailpipe tip can burn you badly.

### **REGENERATION**

Do not park or idle your vehicle over dry leaves, dry grass or other combustible materials. The regeneration process creates very high exhaust gas temperatures and the exhaust will radiate a considerable amount of heat during and after regeneration and after you have switched the engine off. This is a potential fire hazard.

The normal operating temperature of the exhaust system is very high. Never work around or attempt to repair any part of the exhaust system until it has cooled. Use special care when working around the diesel oxidation catalytic converter or diesel particulate filter. The diesel oxidation catalytic converter and the diesel particulate filter heat up to very high temperatures after only a short period of engine operation and remain hot after you switch the engine off.

Stay clear of the exhaust tailpipe during regeneration. Hot exhaust gasses and coming in contact with the tailpipe and/or the tailpipe can burn you badly.

**Figure 1** Banks Monster Exhaust, General Assembly

Item #	Description	Part #	QTY
1	Front Tailpipe	53787	1
2	Rear Tailpipe	53786	1
3	Tip, Tailpipe	52734/52735	1
4	Exhaust Clamp 5"	52473	2
5	Exhaust Clamp 4"	52471	1
6	Banks Urocals	96009	2
7	M14x12 Plug	62248	1
8	M16x12 Plug	62249	1
9	M16 Washer	62250	1

**Figure 2**

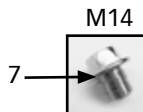
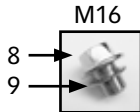
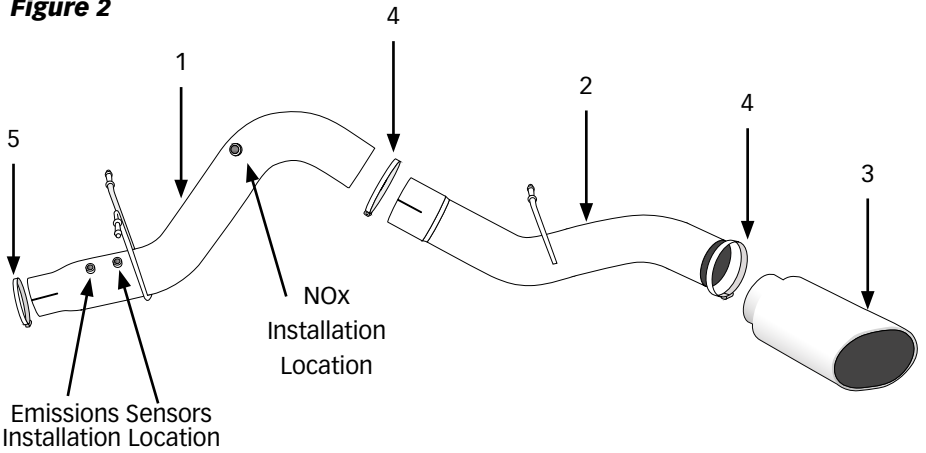

NOTE: No washer required.

# Monster Exhaust System Installation

**1.** As a precaution, disconnect the ground of the battery (if there is more than one battery, disconnect both).

**2.** Raise the vehicle and support it with properly weight rated safety stands, ramps or a commercial hoist. Follow the manufacturer's safety precautions. Take care to balance the vehicle to prevent it from slipping or falling. When using ramps, be sure the front wheels are centered squarely on the topsides; place the transmission in park; set the parking brake and place blocks behind the rear wheels.

**3.** Remove the NOx sensor from the over axle pipe using a 24mm wrench. For short bed models, remove the 2 emissions sensors using a 17mm wrench. Hang the sensors out of the way. They will be reinstalled into the Banks Monster Exhaust.

**CAUTION: DO NOT WORK UNDER ANY VEHICLE SUPPORTED ONLY BY A JACK. SEVERE INJURY MAY RESULT.**

**WARNING! The following step will require the use of a saw. Proper safety equipment should be used. Failure to use proper safety equipment may result in severe injury.**

**4.** The factory exhaust pipe will be cut behind the Factory Diesel Particulate Filter (DPF). Measure from front face of exhaust hanger towards the DPF. See **Figure 3**. Take time when measuring and cutting the factory pipe to ensure the proper location and a straight cut. Improper cut will result in poor fitment of the Banks Monster Exhaust.

**Figure 3**

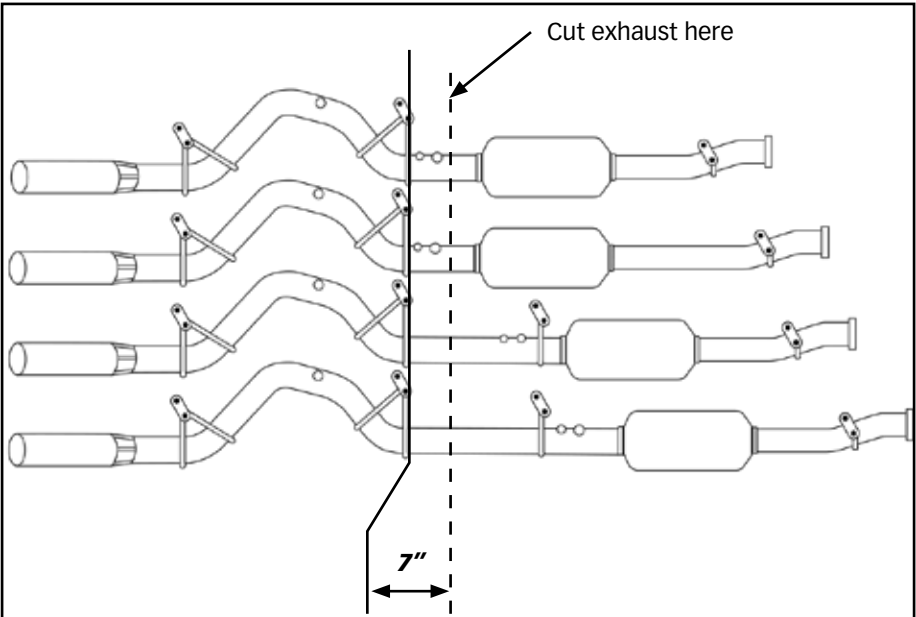

**5.** Remove the factory tailpipe from the vehicle by disengaging the exhaust system hanger pins from the rubber hangers using a large screw-driver or pry bar.

*NOTE: Lubricating the rubber hangers with WD-40 or similar lubricant will ease removal of the hanger pins.*

**6.** Slide a 4" exhaust clamp onto the front of the Banks front tailpipe. Install the front tailpipe onto the cut factory pipe. Loosely snug the 4" clamp.

**7.** Engage the OE rubber hangers onto the hanger clamp pins.

**8.** Install a 5" exhaust clamp onto the inlet of the Rear Tailpipe. Install the Rear Tailpipe onto the outlet of the Front Tailpipe. Insert the Rear Tailpipe hanger pin into the factory rubber hanger. Rotate the tailpipe until the hanger pin is parallel with the frame mounted pin. Loosely snug the 5" clamp.

*NOTE: Maintain an adequate air gap clearance of one (1) inch between the exhaust and the shock absorber and between the exhaust and the spare tire.*

**9.** Reinstall the NOx sensor into the new Front Tail pipe using a 24mm wrench.

**10. Long bed models:** Use the supplied plugs to seal the oem ports on the Banks front tailpipe.

*NOTE: The supplied sealing washer must be installed onto the larger 16mm plug before installing to prevent the plug from bottoming out.*

**11. Short bed models:** Reinstall the 2 emission sensors into the new front tailpipe using a 17mm wrench. Adjust the tube as needed to align with the sensors.

**12.** Install Banks Monster tailpipe tip with exhaust band clamp on the exhaust. Keep the wrapping on until installation is complete.

Be sure the exhaust tip is fully installed against the welded hard stop on the rear tailpipe (See **Figure 4**).

**⚠ CAUTION:** Failure to install the exhaust tip completely against the hard stop may result in the exhaust tip falling off while driving.

**Figure 4**

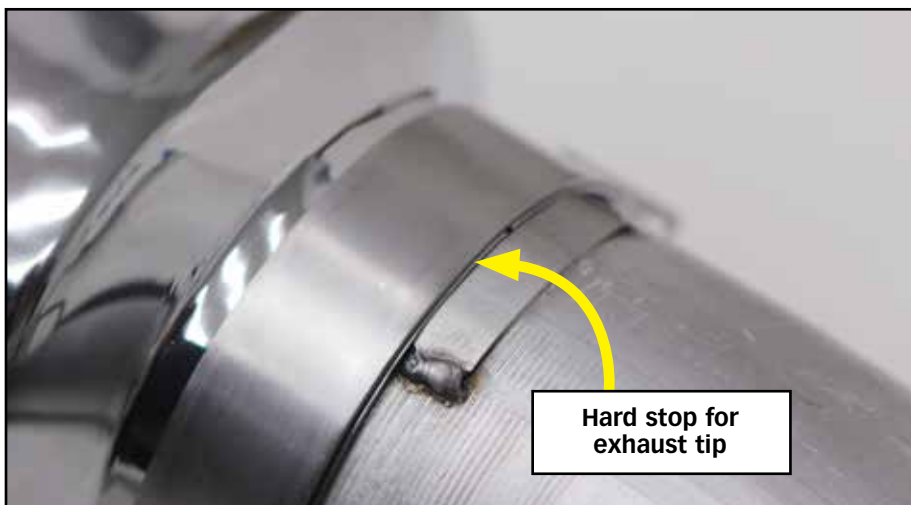

*NOTE: Maintain an adequate air gap clearance of one (1) inch between the exhaust and the shock absorber and between the exhaust and the spare tire.*

**13.** Adjust each of the pipes to ensure that all of the hanger pins are parallel with the frame mounted pins and that the rubber hangers are all positioned slightly forward (See **Figure 5**). This allows the hangers to be properly positioned once the exhaust system reaches operating temperature.

**14.** **Figure 6** illustrates the proper location of an exhaust clamp on a tubing joint.

**15.** With everything positioned properly, begin to tighten the clamps starting with the ones closest to the turbo and working your way back. Tighten all clamps to 50 ft-lbs.

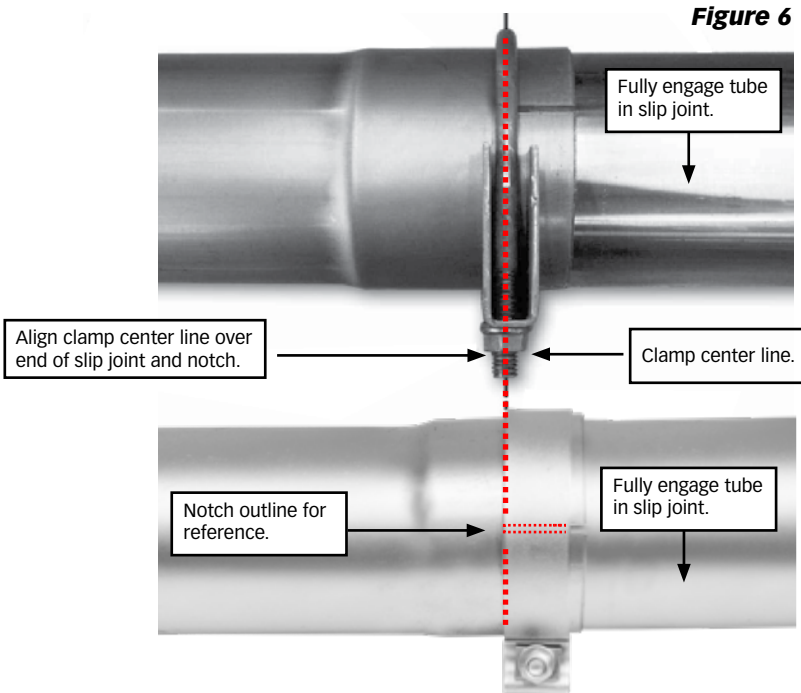
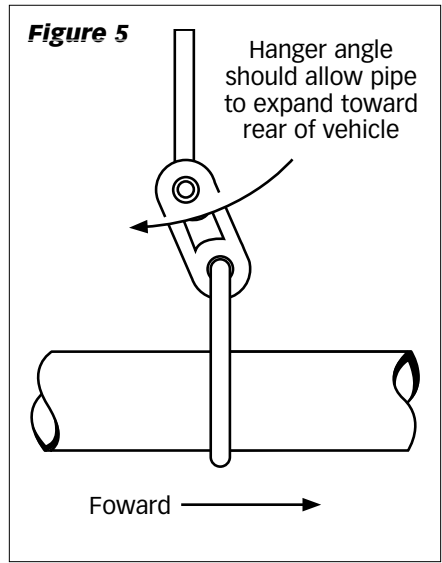

**16.** Remove the protective covering from the tailpipe tip.

**CAUTION: The protective covering may ignite and burn if not removed prior to running the engine.**

**17.** Your system includes two (2) Banks Power decals designed to complement the Duramax emblems on the vehicle's front doors. (See **Figure 7**).

**18.** Re-connect the negative battery cable. Start the engine and listen for exhaust leaks. Tighten the exhaust clamps as necessary. Whenever possible, tack weld slip connections to prevent disengagement is recommended. The Banks Monster Exhaust installation is now complete.

**Figure 7**

