

banks[®]

with Installation Instructions
Owner's Manual

**Banks Monster[®]
Exhaust System**

2017+ Chevy/GMC 6.6L L5P Duramax

THIS MANUAL IS FOR USE WITH SYSTEM 48947, 48947-B, RCLB, DCSB, DCLB,
CCSB, CCLB INCLUDING DUALY MODELS

banks

General Installation Practices

1. Before starting work, familiarize yourself with the installation procedure by reading all of the instructions.

2. The exploded view (**Figure 1**) provides only general guidance. Refer to each step and section diagram in this manual for proper instruction.

3. Throughout this manual, the left side of the vehicle refers to the driver's side, and the right side to the passenger's side.

4. Disconnect the negative (ground) cable from the battery (or batteries, if there are two) before beginning work.

5. Route and tie wires and hoses a minimum of 6" away from exhaust heat, moving parts and sharp edges. Clearance of 8" or more is recommended where possible.

6. When raising the vehicle, support it on properly weight-rated safety stands, ramps or a commercial hoist. Follow the manufacturer's safety precautions. Take care to balance the vehicle to prevent it from slipping or

falling. When using ramps, be sure the front wheels are centered squarely on the topsides; put the transmission in park; set the hand brake; and place blocks behind the rear wheels.

CAUTION! Do not use floor jacks to support the vehicle while working under it. Do not raise the vehicle onto concrete blocks, masonry or any other item not intended specifically for this use.

7. During installation, keep the work area clean. Do not allow anything to be dropped into intake, exhaust, or lubrication system components while performing the installation, as foreign objects will cause immediate engine damage upon start-up.

Tools Required:

- 1/2" and 3/8" drive ratchets with standard and metric sockets and 1/2" and 3/8" drive extension
- Standard and metric combination or open-end wrenches
- Standard screwdriver
- Clean shop towels or rags
- Pry-bar
- Reciprocating saw

Highly recommended tools and supplies:

- Penetrating oil or light lubricant spray

Figure 1 Banks Monster Exhaust, General Assembly

Item #	Description	Part #	QTY
1	Intermediate Pipe	53778	1
2	Front Tailpipe	53777	1
3	Rear Tailpipe	53760	1
4	Tip, Tailpipe	52726/52727	1
5	Exhaust Clamp	52476	2
6	Hanger Clamp	53779	1
7	Exhaust Band Clamp	52471	1
8	Banks Urocals	96009	2
9	M14x12 Plug	62248	1
10	M16x12 Plug	62249	1
11	M16 Washer	62250	1

Figure 2

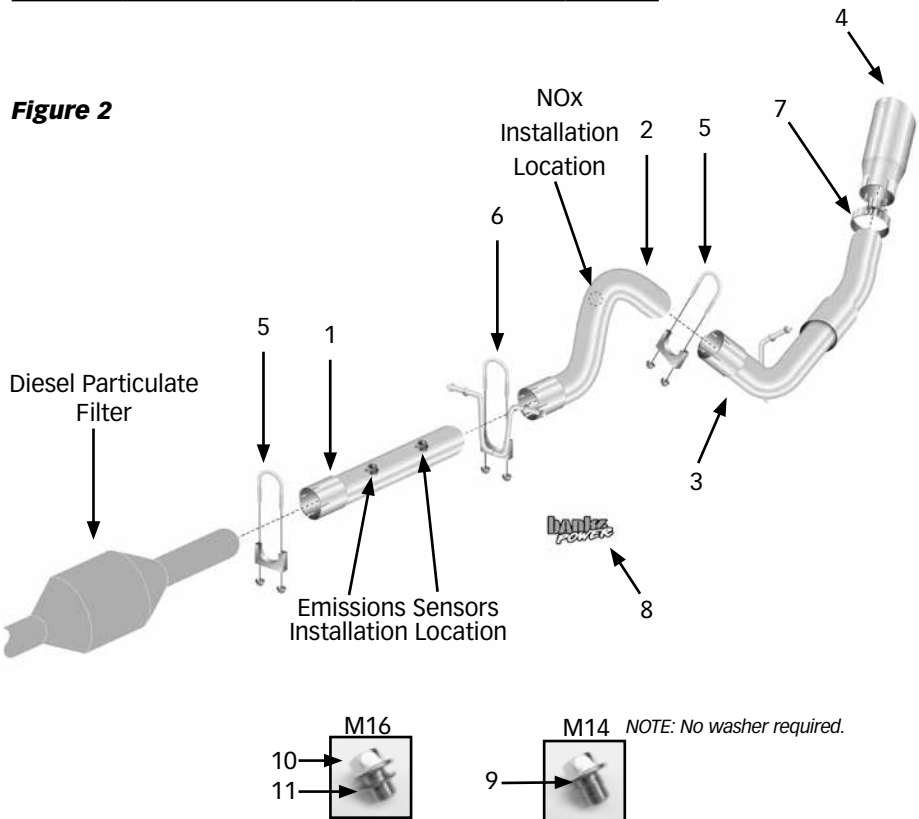

Monster Exhaust System Installation

1. As a precaution, disconnect the ground of the battery (if there is more than one battery, disconnect both).

2. Raise the vehicle and support it with properly weight rated safety stands, ramps or a commercial hoist. Follow the manufacturer's safety precautions. Take care to balance the vehicle to prevent it from slipping or falling. When using ramps, be sure the front wheels are centered squarely on the topsides; place the transmission in park; set the parking brake and place blocks behind the rear wheels.

3. Remove the NOx sensor from the over axle pipe using a 24mm wrench. For short bed models, remove the 2 emissions sensors using a 17mm wrench. Hang the sensors out of the way. They will be reinstalled into the Banks Monster Exhaust.

CAUTION: DO NOT WORK UNDER ANY VEHICLE SUPPORTED ONLY BY A JACK. SEVERE INJURY MAY RESULT.

WARNING! The following step will require the use of a saw. Proper safety equipment should be used. Failure to use proper safety equipment may result in severe injury.

3. The factory exhaust pipe will be cut behind the Factory Diesel Particulate Filter (DPF). Measure from front face of exhaust hanger towards the DPF. See **Figure 3**. Take time when measuring and cutting the factory pipe to ensure the proper location and a straight cut. Improper cut will result in poor fitment of the Banks Monster Exhaust system.

Figure 3

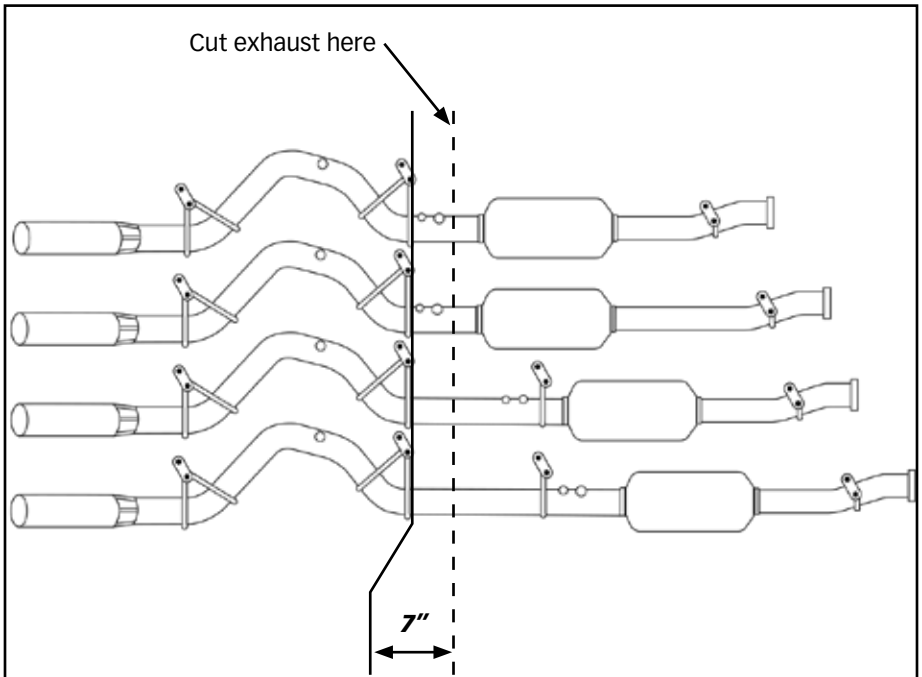

4. Remove the factory tailpipe from the vehicle by disengaging the exhaust system hanger pins from the rubber hangers using a large screw-driver or pry bar.

NOTE: Lubricating the rubber hangers with WD-40 or similar lubricant will ease removal of the hanger pins.

6. Slide a 4" exhaust clamp onto the front of the Banks intermediate pipe. Install the intermediate pipe onto the cut factory pipe. Slide the 4" clamp and position as shown in **Figure 4**. Loosely snug the 4" clamp.

7. Slide the 4" exhaust hanger clamp onto the front of the Banks Front Tailpipe.

8. Route the Front Tailpipe over the rear axle housing and install onto the intermediate pipe outlet. Engage the OE rubber hangers onto the hanger clamp pins. Be sure that the two pipes are completely engaged. Loosely snug the 4" exhaust clamp.

*NOTE: The front tail pipe must be angled towards the center of the truck as shown in **Figure 4** for the rear tailpipe to exit in the right location.*

Figure 4

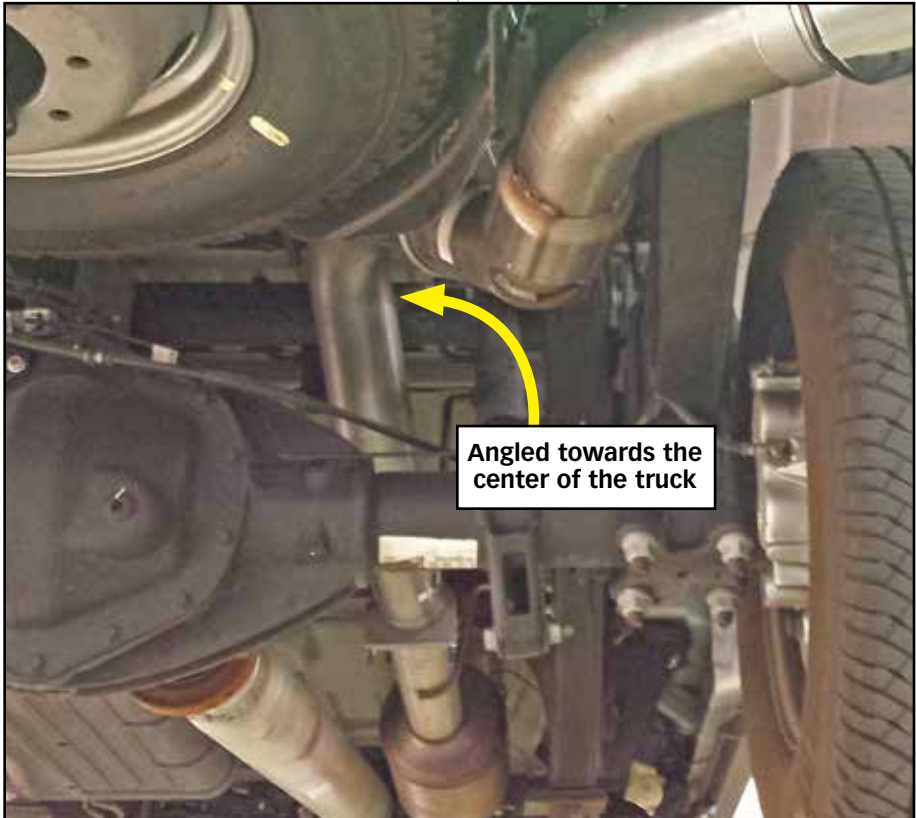

9. Install a 4" exhaust clamp onto the inlet of the Rear Tailpipe. Install the Rear Tailpipe onto the outlet of the Front Tailpipe. Insert the Rear Tailpipe hanger pin into the factory rubber hanger. Rotate the tailpipe until the hanger pin is parallel with the frame mounted pin. Slide the 4" clamp and position as shown in **Figure 5**. Loosely snug the 4" clamp.

NOTE: Maintain an adequate air gap clearance of one (1) inch between the exhaust and the shock absorber and between the exhaust and the spare tire.

10. Reinstall the NOx sensor into the new Front Tail pipe using a 24mm wrench.

11. For long bed models, use the supplied plugs to seal the oem ports on the Banks Intermediate Pipe.

NOTE: The supplied sealing washer must be installed onto the larger 16mm plug before installing to prevent the plug from bottoming out.

12. For short short bed models, reinstall the 2 emission sensors into the new intermediate pipe using a 17mm wrench. Adjust the tube as needed to align with the sensors.

13. Install Banks Monster tailpipe tip with exhaust band clamp on the exhaust. Keep the wrapping on until installation is complete. Adjust the tip past the edge of the body or where aesthetically pleasing. Loosely snug the 4" clamp.

NOTE: Maintain an adequate air gap clearance of one (1) inch between the exhaust and the shock absorber and between the exhaust and the spare tire.

Figure 5

Align clamp center line over end of slip joint and notch.

Fully engage tube in slip joint.

Clamp center line.

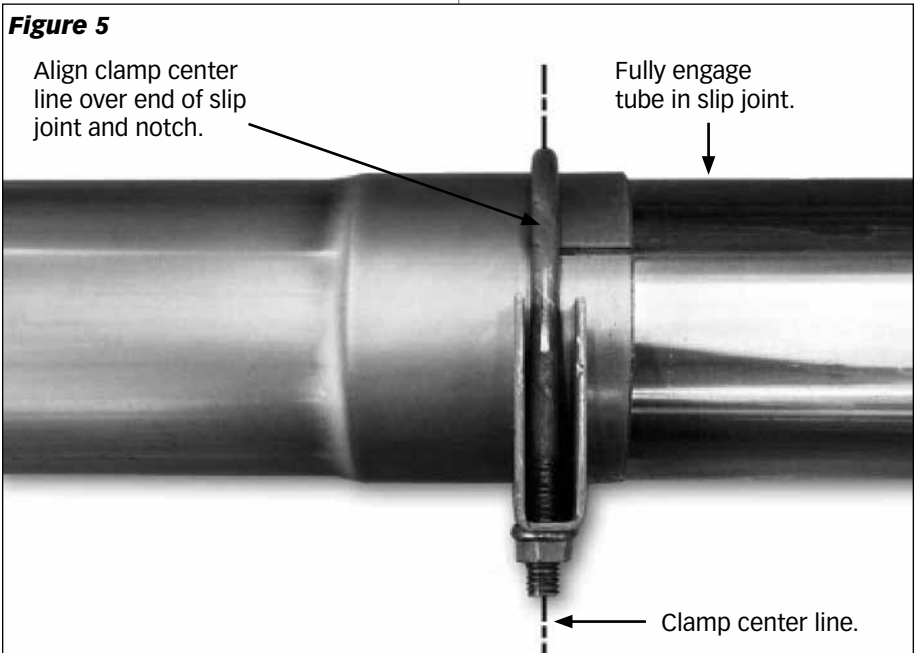

14. Adjust each of the pipes to ensure that all of the hanger pins are parallel with the frame mounted pins and that the rubber hangers are all positioned slightly forward (See **Figure 6**). The amount of forward angle on the rubber hangers should increase the farther downstream the hanger is positioned. This allows the hangers to be properly positioned once the exhaust system reaches operating temperature.

15. **Figure 5** illustrates the proper location of an exhaust clamp on a tubing joint. Tighten the clamp until the tube begins to deform.

NOTE: The clamps only need to be tight enough to form a seal and hold the pipes together. Over tightening the clamps may cause the system to leak due to the pipe being crimped.

16. Remove the protective covering from the tailpipe tip.

CAUTION: The protective covering may ignite and burn if not removed prior to running the engine.

