

**banks**<sup>®</sup>

# Owner's Manual with Installation Instructions

## **Banks Big Hoss<sup>®</sup> Intake Manifold System**

**2003-2007 (235, 250, 305 and 325 HP)  
Dodge Cummins 5.9L (24-valve) ISB Pickup Trucks**

THIS MANUAL IS FOR USE WITH KITS 42747

**banks**

## Also Available from Banks Power



### **Banks iQ System (P/N 61148-61149)**

- 5" touchscreen interface that can control the Banks Diesel Tuner on the fly.
- Interchangeable gauge display, read and clear codes, monitor engine diagnostics, log data, time your vehicles runs and much more

### **Banks Monster® Exhaust System**

**Single (P/N 48640-48643, 48700, 48701, 48708)**

**Duals (P/N 48702-48707, 48709)  
Sport (P/N 48777-48780)**

- Increases exhaust flow, cuts backpressure, lowers exhaust gas temperatures (EGTs) and increases power

### **Banks Ram-Air Intake System (P/N 42145)**

- Increases your airflow over stock.
- Adds power, improves fuel economy, lowers EGTs and reduces smoke

### **Banks Ram-Air Intake Super-Scoop (P/N 42190-42191)**

- Adds cooler denser air to the Ram-Air Intake housing, further increasing fuel economy, reducing smoke and lowers EGTs

### **Banks Monster-Ram (P/N 42765-42766)**

- Increased flow from intercooler
- Raises boost without increasing backpressure at the turbine

### **Banks Techni-Cooler® System (P/N 25980-25981)**

- Provides increased air flow to the engine by increasing air density for more increased power, lower EGTs and improved fuel economy

### **Banks Exhaust Brake (P/N 55222-55229)**

- Increases the stopping power of your truck and extends the service life of your brakes

### **Banks SmartLock (P/N 55270)**

- Reduces wear on transmission
- Locks Torque Converter and raises trans-line pressure
- Works with Banks Exhaust Brake

### **Banks Billet Torque Converter (P/N 72515)**

- Higher torque capacity over stock
- Lockup clutch is slip-resistant so transmission fluids stay cooler and transmission life is prolonged

### **Banks Bullet (P/N 66522-66523)**

- Adds power safely to your vehicle
- Displays critical engine functions
- Engine safeguards
- Change power levels on-the-fly

### **Boost and Pyro Gauges (P/N 64507)**

- Keep your engine safe by monitoring vital engine parameters

**Banks BigHead® Actuator  
(P/N 24331)**

- Achieves a higher peak boost over stock and gives you precise boost control that gives you crisp acceleration and more mid-range pulling power

**Banks Diesel Tuner  
EconoMind w/switch  
(P/N 63725, 63793, 63795, 64507)**

**EconoMind w/iQ  
(P/N 63807, 63808, 63817, 63818)**

**Six-Gun w/switch  
(P/N 61022, 63797)**

**Six-Gun w/iQ  
(P/N 63809, 63819)**

- Adds power safely to your vehicle
- Engine and transmission safeguards
- Change power levels on-the-fly

**Thermocouple**

- Add a temperature limiting function to your Diesel Tuner

**Banks Speed-Loader  
(P/N 62981)**

- Furthers the power output of the Banks Six-Gun and provides EGT limiting safety

**Banks Stinger Systems  
(P/N 49692-49699, 49708-49711, 49716-49721)**

**Contains:**

- Ram-Air Intake system
- Monster Exhaust (single or dual)
- EconoMind Tuner w/ Banks iQ
- Big Head Wastegate Actuator

**Banks PowerPack Systems  
(P/N 49700-49707, 49712-49715, 49722-49727)**

**Contains:**

- Ram-Air Intake system
- Monster Exhaust (single or dual)
- EconoMind Tuner w/ Banks iQ
- Big Head Wastegate Actuator
- Monster-Ram
- Techni-Cooler System

**Banks Six-Gun Bundle  
(P/N 49728-49735, 49744-49747, 49752-49757)**

**Contains:**

- Ram-Air Intake system
- Monster Exhaust (single or dual)
- Six-Gun Tuner w/ Banks iQ
- Big Head Wastegate Actuator

**Banks Big Hoss Bundle  
(P/N 49736-49743, 49748-49751, 49758-49763)**

**Contains:**

- Ram-Air Intake system
- Monster Exhaust (single or dual)
- Six-Gun Tuner w/ Banks iQ
- Big Head Wastegate Actuator
- Monster-Ram
- Techni-Cooler System

# Section 1

## SYSTEM DESCRIPTION

### Table of Contents

<b>Section 1</b> .....	<b>4</b>
System Description	
<b>Section 2</b> .....	<b>4</b>
Cylinder Head Preparation	
<b>Section 3</b> .....	<b>5</b>
Bandsaw Rough Cut	
<b>Section 4</b> .....	<b>6</b>
Machining Manifold Face	
<b>Section 5</b> .....	<b>8</b>
Drilling and Tapping	
<b>Section 6</b> .....	<b>8</b>
Port Matching	
<b>Section 7</b> .....	<b>10</b>
Intake Manifold to Cylinder Head Assembly	
<b>Bill of Materials</b> .....	<b>13</b>

The Banks Big Hoss Intake Manifold and Techni-cooler system is intended for the driver who wants engine performance levels well above and beyond those which can be achieved by only bolt-on external components. The system dramatically increases airflow and air density by removing intake restrictions while reducing charge-air temperature. This provides increased performance with a given boost or even greater performance at elevated boost levels. The intake manifold portion of the system may be purchased separately for customers who already have the Banks Techni-cooler installed in their vehicle. The Big Hoss manifold is ideal for custom and competition installations where extensive cylinder head and injection modifications are planned.

Installation of the Banks Big Hoss intake manifold dramatically reduces intake air restrictions through the removal of the internal intake manifold portion of the cylinder head and the

elimination of the separate elbow casting. Furthermore, the removal of the cast-on intake manifold allows the engine assembler access to the intake ports for the optional porting and blending of the intake runners.

### Important

Installing the Banks Big Hoss manifold requires removing the cylinder head, disassembly and removal of all injection and valve train components, sawing off the intake portion of the cylinder head, and re-machining the head to accept the manifold. Persons performing this work should be familiar with engine disassembly and assembly procedures, and should have a shop manual for the engine and vehicle to be modified. Access to a machine shop with an industrial band saw and vertical milling machine is required. A block and head surfacer may be used for the flange finishing operations. A machining drawing for the milling and tapping operations is provided for your machinist.

-END, SECTION 1-

# Section 2

## CYLINDER HEAD PREPARATION

The cylinder head must be removed from the engine and completely stripped of all valve train and fuel injection components. Remove the intake inlet elbow and manifold cover plate from the intake side of the head. The head should be thoroughly cleaned and inspected

for any defects or damage (cracks, leaks, or porosity) that would make it unsuitable for high performance use. See shop manual for disassembly and inspection procedures, repair or replace the head as is necessary.

-END, SECTION 2-

## Section 3

### BANDSAW ROUGH CUT

All position references for bandsawing and machining are measured from the front cylinder headbolt dowel hole (right front hole) next to the thermostat pocket. Viewing the head from above, locate this hole and the row of head bolts down the right side of the head. (7 total) From the centerline of this row of head bolt holes, measure  $6 \frac{1}{4}$  inches toward the intake side and scribe a line the length of the head. (See **Figure 1**) This should place the line about  $\frac{1}{4}$  inch away from the outer edge of the rocker cover rail flange on the intake gasket surface. This will be the bandsaw cut line to remove the bulk of the cast-on intake manifold trough.

Tape a piece of heavy cardboard to the head gasket surface of the cylinder head to protect it from scratches caused by the saw table. A guide bar may be clamped to the saw table to align with exhaust port gasket face as the head is moved forward. Cut the intake trough from the head just outside the scribe line. This cut will leave approximately .220 inch of material on the intake face of the head for machining.

-END, SECTION 3-

**Figure 1**

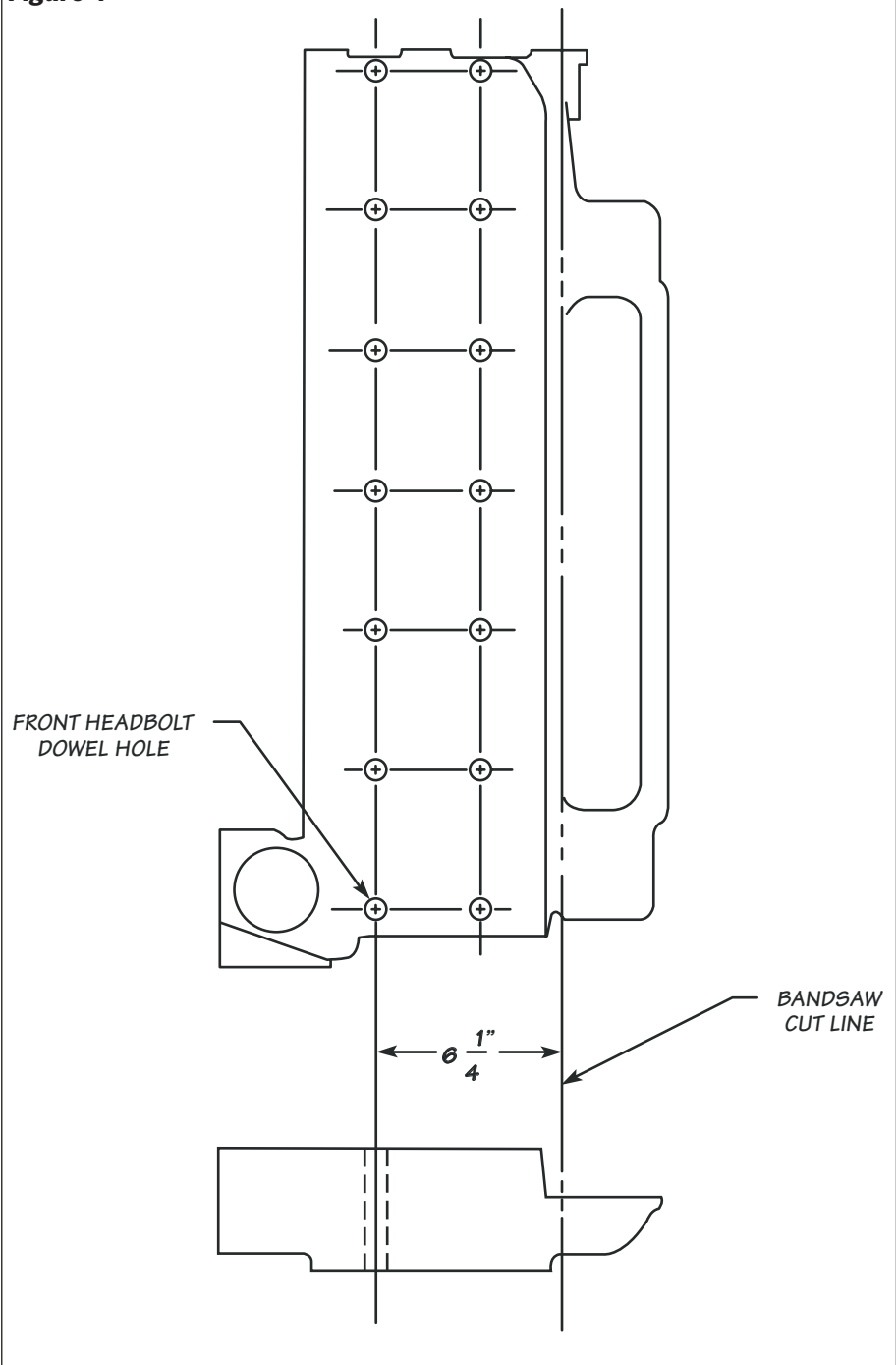

## Section 4

### MACHINING MANIFOLD FACE

Figure 2

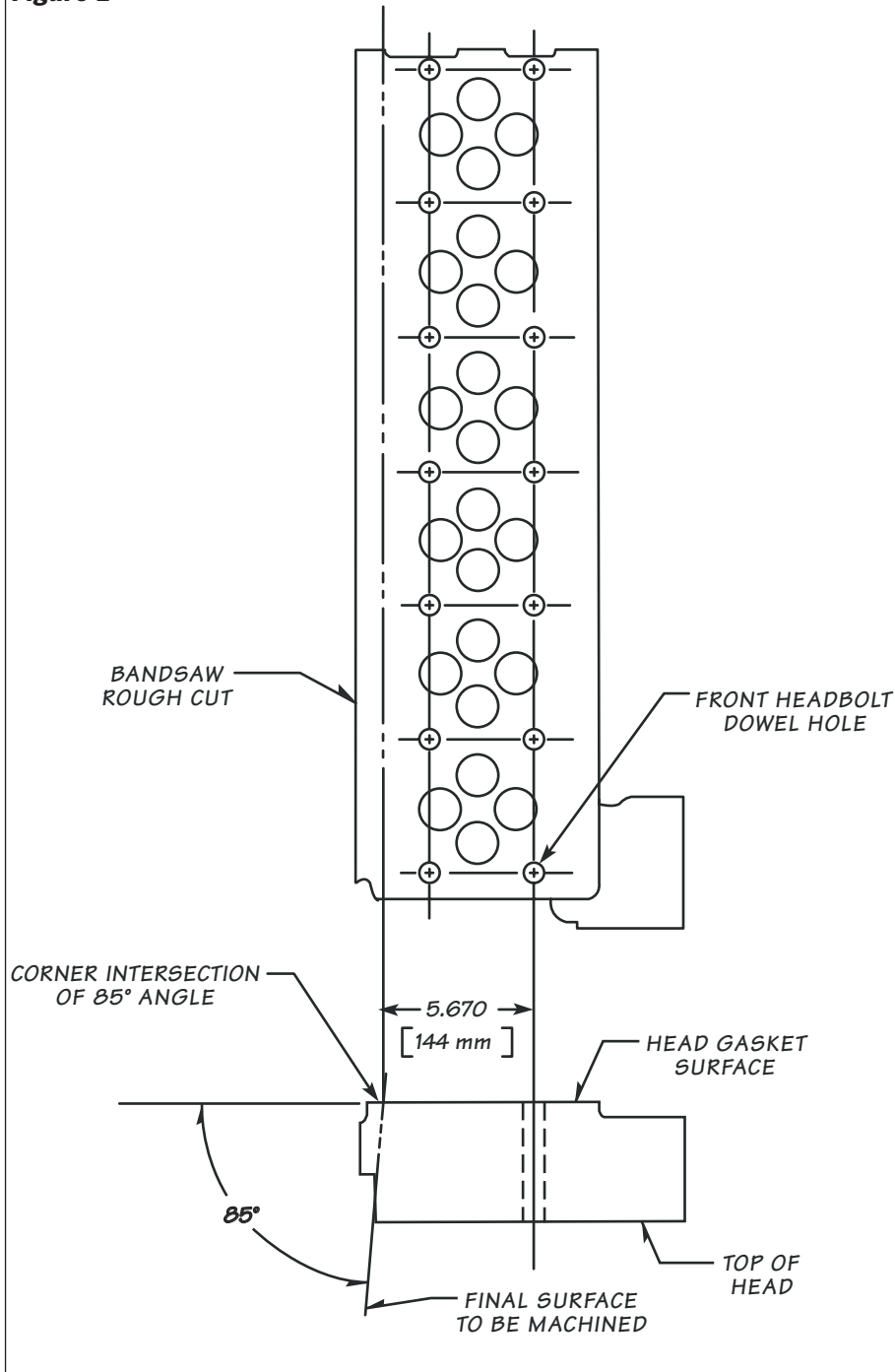

Turn the cylinder head over so the head gasket surface faces up. Once again locate the front head bolt dowel hole and corresponding row of seven head bolt holes. From an accurate location of the centerline of this row of head bolt holes, measure and scribe a reference line the length of the head 5.670 inches [144mm] toward the intake port side of the head. This line will be the corner intersection of the head gasket surface and the new intake manifold seal surface. (See **Figure 2**)

The intake manifold seal surface must be machined at an 85° angle to the head gasket surface (5° off a vertical when installed on the engine). The machining may be done using a block/head surfacer or a milling machine with enough table travel to cover the length of the head. The cut will likely require a number of passes to reach the finished dimension at the 85° angle. (See **Figure 3**) The finished surface cut should come to or be just below the rocker cover gasket rail surface on the intake face of the head. 100% clean-up of the as-cast head below the rocker cover rail flange is not required.

-END, SECTION 4-

Figure 3

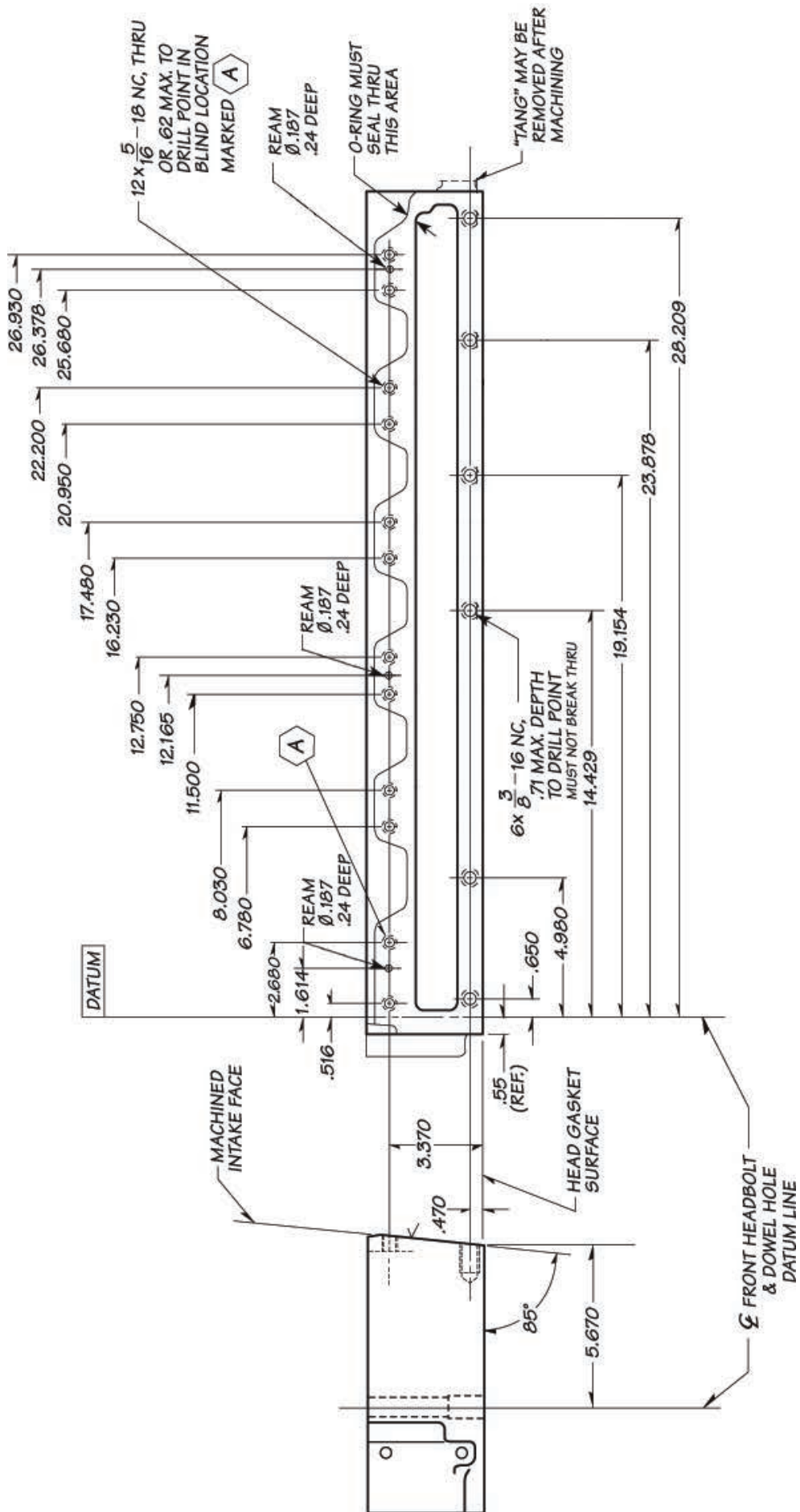



## Section 5

### DRILLING AND TAPPING

The layout for the drilled and tapped holes on the machined intake face is referenced from the centerline of the front head bolt and the head gasket surface of the head. **Figure 3** shows the locations of the upper and lower bolt hole rows, as well as the three (3) dowel pin holes.

**IMPORTANT:** Note that all hole centerlines are SQUARE TO THE HEAD GASKET SURFACE of the head. Not the angled surface that was milled. It may be desirable to

mill a ¼ inch diameter flat spot at each hole location to prevent the tapdrill from walking off center. All but one of the upper row of twelve 5/16-18 tapped holes are drilled and tapped through the outer wall of the rocker cover rail. The lower row of six 3/8-16 tapped holes must not exceed the indicated tap drill depth to prevent the holes from breaking through into the water jackets. Before drilling, verify that your head has enough material to accommodate the indicated tap

drill depth. These holes must be bottom-tapped to provide the proper bolt thread engagement.

The dowel pin holes may be drilled or drilled undersize and then reamed (this is the preferred method). The dowel pins provide alignment and allow the manifold to expand with temperature change while maintaining proper top-to-bottom position.

-END, SECTION 5-

## Section 6

### PORT MATCHING

No further machining operations are required for manifold installation however the milled intake surface opening on the head should be ground to match the manifold opening for optimum airflow. The milled surface on the head should be sprayed with layout dye and the three (3) dowel pins supplied tapped into place. Dowel pins should protrude no further than .200 above the milled surface.

Install the O-ring in the groove on the intake manifold flange face. Take care that the O-ring does not get stretched or twisted.

Coat the exposed surface of the O-ring with enough white grease so it will leave an imprint of its position when bolted to the cylinder head. Temporarily bolt the manifold to the cylinder head with 8-10 bolts (See **Figure 4** for bolt locations), washers must be in place on long bolts to draw bolts against manifold.

Using a sharp scribe, reach through the 4-inch diameter

hose inlet and scribe a line on the head at the head-to-manifold junction at all places where the milled head surface hangs into the manifold opening. A piece of stiff welding rod ground to a sharp point or a hook scribe may be used to reach farther into the manifold. Once the head has been marked as far as possible through the manifold opening, remove the manifold from the head and observe the O-ring imprint on the head surface to determine where you can safely grind head material away near the O-ring groove.

We suggest you keep your grinding no closer than .050 to the inner edge of the O-ring groove. Pay particular attention to the O-ring sealing at the upper rear corner of the cylinder head intake opening where the O-ring has a very narrow sealing path. The sharp tang which is left on the outside of the head at the rear may be cut off flush with the rear of the intake manifold flange.

If additional cylinder head porting and valve work is to be done, it should be completed at this time. Once all headwork is completed, the head may be cleaned, reassembled, and reinstalled on the engine per the service manual reassembly procedure.

*NOTE: Some cylinder head gaskets have tabs, which extend out from the head-to-block junction on the intake side of the engine. These tabs should be bent down after the head is installed to clear the bottom of the intake manifold.*

The three throttle control bosses on the top/front of the intake manifold may be cut off if removal is required for a second injection pump as part of a dual pump kit. This modification should be done prior to intake manifold installation

-END, SECTION 6-



Figure 4

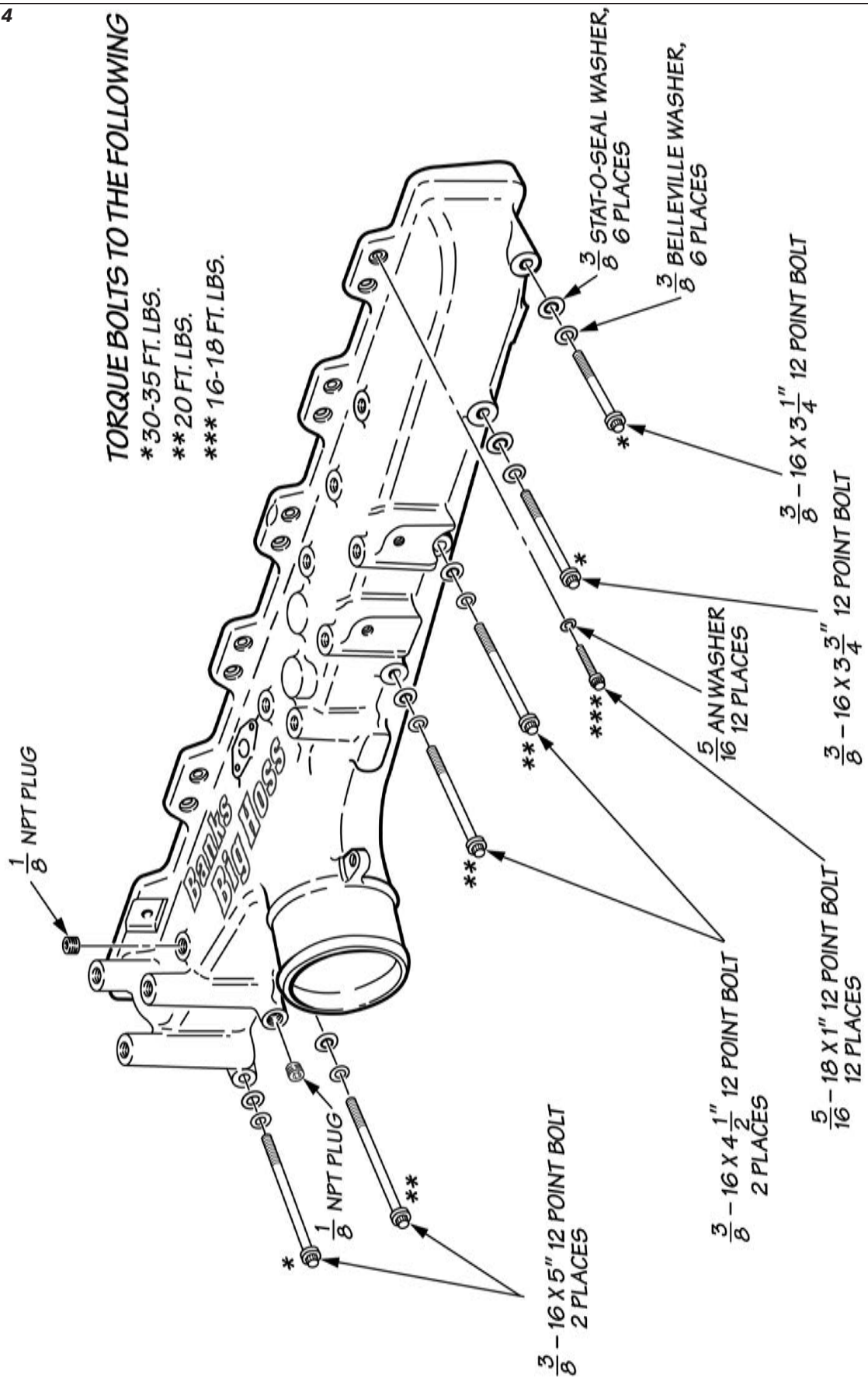

## Section 7

### INTAKE MANIFOLD TO CYLINDER HEAD ASSEMBLY

**1.** If not previously installed, tap the three (3)  $\frac{3}{16}$  x  $\frac{3}{8}$  dowel pins into holes on the cylinder head intake flange face. Dowel pins must not protrude more than .200 inch from the milled surface of the head.

**2.** Install the o-ring into the groove on the intake manifold. Remove any excess grease from the o-ring that may be left from the port-matching imprint procedure. Take care that the o-ring does not get stretched or twisted during installation.

**3.** Install manifold, bolts and washers as shown in **Figure 4**. Place a  $\frac{5}{16}$  AN washer on each of the  $\frac{5}{16}$ -18 x 1" upper manifold bolts. Apply Teflon sealant to the first 5-6 threads of each bolt and install manifold with o-ring against cylinder head, lightly snug all bolts.

**4.** Place a  $\frac{3}{8}$ -inch conical (Belleville) washer on each of the six  $\frac{3}{8}$  inch lower manifold bolts. (Dished side faces away from bolt head). Apply a drop of oil on the o-ring of each  $\frac{3}{8}$  Stat-O-Seal washer and slide washers against the conical washers on the lower manifold bolts.

**5.** Working from the center outward, install the lower manifold bolts and torque the inner bolts to 20 ft. lbs. Torque the two outer bolts on the longer side and the outer bolt on the short side to 30-35 ft. lbs. Torque upper manifold bolts to 16-18ft. lbs. See **Figure 4**.

**6.** Install fuel rail with three M8 x 40 mm hex bolts. Lightly snug the bolts.

**7.** Install high-pressure injector nozzle lines and clamp brackets. Apply Teflon sealant to the first 5-6 threads of the four factory clamp bracket bolts, install bolts but leave bolts loose. Tighten nozzle lines at head and fuel rail, then tighten bracket bolts and fuel rail bolts. Torque bolts to 12-14 ft. lbs..

**8.** Lightly oil o-ring on factory MAP/TEMP sensor and install in bore on top of manifold. Apply a very small amount of Teflon sealant to the two factory mounting screws and tighten.

**9.** Install two socket head  $\frac{1}{8}$  NPT pipe plugs in ports on intake manifold. Both ports are located near the front of the manifold, one on the top and one on the side. A mechanical boost gauge

or other boost-sensing device may be connected to either port. Use Teflon sealant on the pipe threads.

**10.** Reconnect electrical wire looms to injector plugs and engine sensors. Reroute engine wire looms if necessary. Unused intake heater wiring should be removed. An M6 x 12mm hex bolt and M6 lock washer is provided to anchor the factory wire loom clamp to the front flange of the intake manifold next to the head. An additional M6 x 35mm hex bolt, M6 lock washer, and 1" x  $\frac{1}{4}$  I.D. spacer are provided to anchor the factory wire loom clamp to the bottom of the intake manifold behind the fuel filter.

**11.** Mount the fuel filter assembly bracket to the side of the manifold using the factory bolts and reconnect the low pressure fuel lines. Reinstall the high-pressure fuel line from the fuel injection pump to the fuel rail and tighten.

**12.** On vehicles where the throttle controller was originally bolted to the cylinder head, proceed to **step 13**. On all other installations, install the coarse threaded end of a  $\frac{1}{4}$  X 1  $\frac{1}{4}$  stud in the front "ear" on the 4-inch diameter inlet hose joint of the Big Hoss intake manifold. Temporarily use two  $\frac{1}{4}$ -28 hex jam nuts tightened against each other on the fine threads to tighten the stud. Once tight, remove the nuts and proceed to **step 17**.

**13.** Reinstall the throttle controller assembly on the three bosses at the top/front of the intake manifold using the factory bolts. From inside the cab, check that the throttle pedal moves smoothly through its full travel.

**14.** Install an M6 spring clip nut on the upper rear throttle controller cover tab (see **Figure 5**). Reinstall plastic throttle controller cover using all but one

**Figure 5**



plastic fastener where the clip nut was installed.

**15.** Bend dipstick tube as required allowing dipstick tube bracket to be fastened to the clip nut on the throttle controller with an M6 x 50mm hex bolt and 1-inch long spacer. Install bolt with M6 split lock washer and  $\frac{1}{4}$  SAE washer thru spacer into clip nut on controller and tighten. (See **Figure 6**)

**16.** If the Big Hoss intake manifold is being installed along with a Banks Techni-Cooler charge air-cooler in a Dodge pickup, install the Techni-Cooler kit at this time, then continue with these instructions at the point where the boost tube is to be installed in the Techni-Cooler kit. Once the boost tube and related hardware is installed, complete any remaining steps in the Techni-Cooler kit.

**17.** Thread a  $\frac{1}{4}$ -28 hex jam nut onto each of the four  $\frac{1}{4}$ -inch rod-end bearing. Thread a  $\frac{1}{4}$ -inch rod-end bearing into each end of the two  $\frac{3}{8}$  x 5-inch long hex links. These links will span each side of the 4-inch dia. inlet hose joint on the intake manifold to prevent the boost tube from blowing out under high boost conditions.

**18.** The links and bearing should be adjusted to approximately a  $6\frac{3}{4}$ -inch center-to-center distance. This will provide an average of  $\frac{1}{8}$  to  $\frac{1}{4}$ -inch gap at the hose joint between the manifold and the boost tube. If you are fabricating a boost tube for a custom installation, locate bolt tabs on the boost tube to provide the  $\frac{1}{8}$  to  $\frac{1}{4}$ -inch gap at the hose joint. Once adjusted, tighten the jam nuts against the links.

**19.** Install the 4-inch dia. x  $3\frac{1}{2}$ -inch long silicone hose onto the

**Figure 6**



inlet hose nipple on the intake manifold. Push the hose on the nipple until it comes against the stop bead on the manifold. Slide two 4.25-inch hose clamps over the hose, but do not tighten. Push the boost tube into the hose until it contacts the manifold nipple, then pull it out  $\frac{1}{8}$  to  $\frac{1}{4}$  inch to provide the recommended gap.

**20.** Tighten the hose clamps, make sure the clamps are positioned behind, not over, the hose bead part of the manifold and boost tube hose nipples.

**21.** Insert a  $\frac{1}{4}$ -20 x 12 pt. bolt thru a rod-end bearing in one of the link assemblies and thread it into the rear "ear" on the 4-inch inlet hose joint on the Big Hoss manifold and tighten.

**22.** Install the remaining link assembly on the front "ear" on the Big Hoss manifold using either a  $\frac{1}{4}$ -20 x  $\frac{3}{4}$  12pt. bolt, or, if a stud was installed in **step 12**, by passing the rod-end over the  $\frac{1}{4}$  X  $1\frac{1}{4}$  - inch stud and using

the third  $\frac{3}{8}$  x 5-inch hex link as a nut on the stud and tighten. See **Figure 7** and **8**.

**23.** Bolt the free end of each link assembly to the upper side of the two tabs on the boost tube using a pair of  $\frac{1}{4}$ -28 x 1 hex bolts,  $\frac{1}{4}$ -inch AN washers, and  $\frac{1}{4}$ -28 Nylock nuts.

**24.** If the dipstick was mounted to the top of the throttle controller in steps 15, the installation of the Big Hoss manifold is complete. Otherwise, bend the dipstick tube as required to allow the dipstick tube bracket to be bolted to the top of the vertical hex link. Install a  $\frac{1}{4}$ -28 x 1" hex bolt, a  $\frac{1}{4}$ -inch split lock washer, and two  $\frac{1}{4}$ -inch SAE washers thru the dipstick tube bracket and into the hex link, then tighten the bolt. This completes the installation of the Big Hoss intake manifold.

-END, SECTION 7-

**Figure 7**

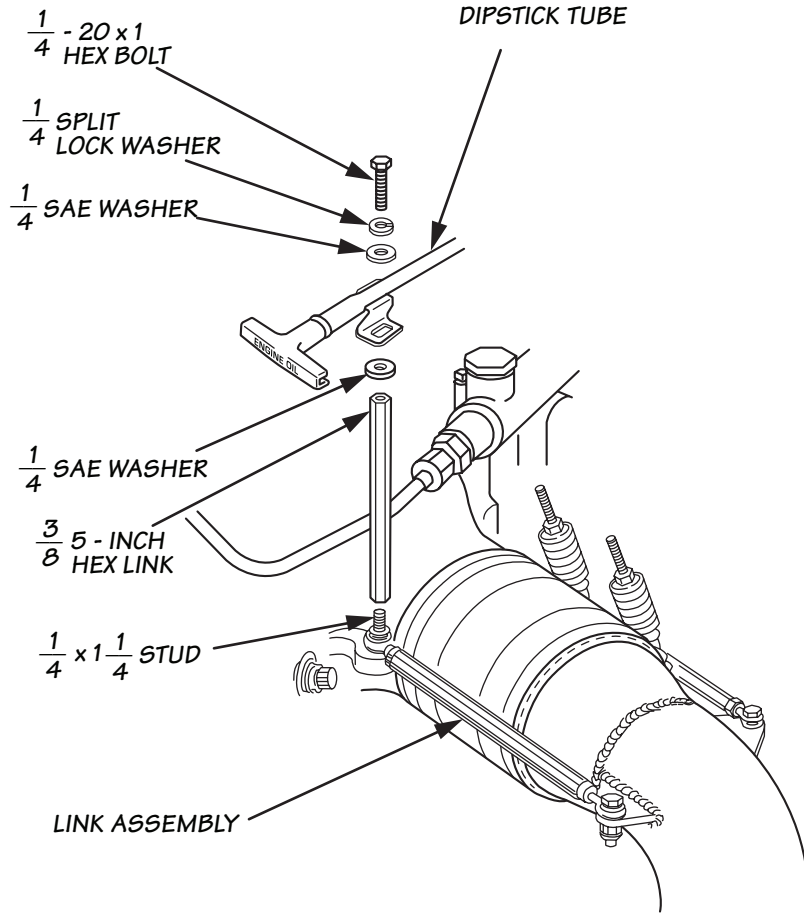

**Figure 8**

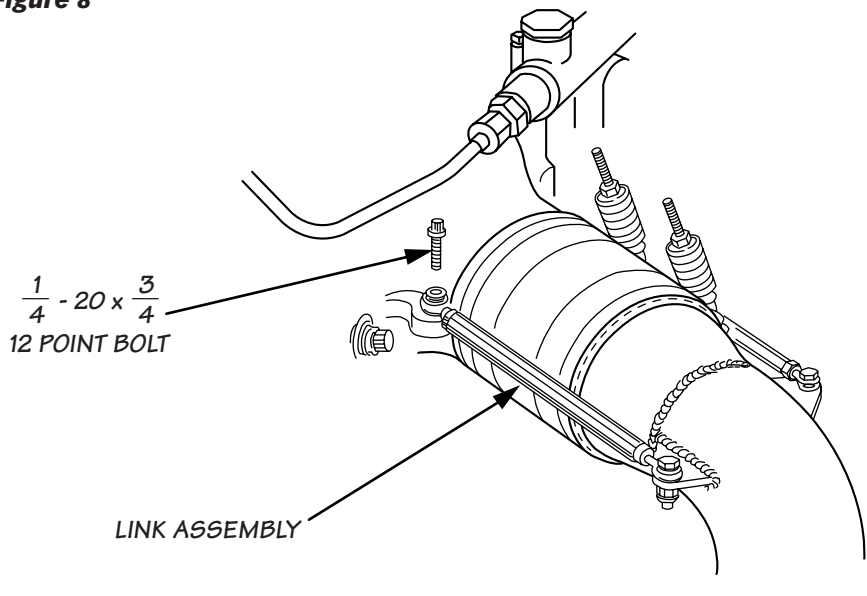

# Bill of Materials

Item	Part No.	Qty.	Description
1	42748	1	Intake Manifold
2	41315-09	2	Tab-Boost Tube
3	90040	1	Sealant, PTFE paster
4	92780	4	Rod end bearing, 1/4 - 28 R.H. Male shank x 1/4 dia. hole.
5	92898	2	Hose Clamp, T-bolt, 4.00 to 4.50 dia. range, stainless
6	93820	1	O-Ring, 3/32 x 20.0" I.D., Nitrile 70 durometer
7	94320	1	Hose, silicon, 4.00 I.D. x 3.5 long, 5-ply Aramid, black
8	35290	2	Spacer, 1/2 O.D. x 1/4 I.D. x 1.00 long, steel, zinc plated
9	91101	2	Washer, 1/4" AN, SS
10	91111	2	Nut, 1/4 - 28, nylock
11	91126	4	Jam Nut (thin hex), 1/4 - 28, zinc plated
12	91127	2	Bolt, 1/4 - 20 x 3/4, 12 point, Gold Zinc
13	91140	2	Bolt, 1/4 - 28 x 1", hex head, zinc plated
14	92760	1	Stud, 1/4 X 1 1/4"
15	91201	12	Washer, 5/16" AN, SS
16	91230	12	Bolt, 5/16 - 18 x 1.00, 12 point, zinc plated
17	91413	6	Washer, Stat-o-seal, 3/8"
18	91414	6	Washer, 3/8 belleville (0.4131 I.D. x 0.63 O.D.), zinc plated
19	91481	1	Bolt, 3/8 - 16 x 3.25, 12 point, zinc plated
20	91483	1	Bolt, 3/8 - 16 x 3.75, 12 point, zinc plated
21	91485	2	Bolt, 3/8 - 16 x 4.50, 12 point, zinc plated
22	91487	2	Bolt, 3/8 - 16 x 5.00, 12 point, zinc plated
23	91695	3	Washer, M6, split lock, zinc plated
24	91738	1	Bolt, M6 x 1.0 x 12mm, hex head, 8.8, zinc plated
25	91743	1	Bolt, M6 x 1.0 x 35mm, hex head, 8.8, zinc plated
26	91746	1	Bolt, M6 x 1.0 x 50mm, hex head, 8.8, zinc plated
27	91773	1	Speed Nut, U-clip, M6 x 1.0, for 3.2mm panel thickness
28	91814	3	Bolt, M8 x 1.25 x 40mm, hex head, 8.8, zinc plated
29	91938	3	Dowel Pin, 3/16 dia. x 3/8 long
30	92251	2	Pipe Plug, 1/8" NPT, socket head, zinc plated
31	92760	3	Link