

**banks**

with Installation Instructions  
**Owner's Manual**

**Banks Big Hoss<sup>®</sup>  
Intake Manifold  
System**

**2001-2007 Chevy/GMC Duramax Turbo-Diesel  
Engines**

THIS MANUAL IS FOR USE WITH KITS 42733

**BANKS**

# General Installation Practices

**THIS IS A HIGH PERFORMANCE PRODUCT. USE AT YOUR OWN RISK.**

**Do not use this product until you have carefully read the following agreement.**

**This sets forth the terms and conditions for the use of this product. The installation of this product indicates that the BUYER has read and understands this agreement and accepts its terms and conditions.**

## Disclaimer of Liability

Gale Banks Engineering Inc., and its distributors, employees, and dealers (hereafter "**SELLER**") shall in no way be responsible for the product's proper use and service. The **BUYER** hereby waives all liability claims.

The **BUYER** acknowledges that he/she is not relying on the **SELLER's** skill or judgment to select or furnish goods suitable for any particular purpose and that there are no liabilities which extended beyond the description on the face hereof and the **BUYER** hereby waives all remedies or liabilities, expressed or implied, arising by law or otherwise, (including without any obligations of the **SELLER** with respect to fitness, merchantability, and consequential damages) whether or not occasioned by the **SELLER's** negligence.

The **BUYER** is responsible to fully understand the capability and limitations of his/her vehicle according to manufacturer specifications and agrees to hold the **SELLER** harmless from any damage resulting from the failure to adhere to such specifications. The **SELLER** disclaims any warranty and expressly disclaims any liability

for personal injury or damages. The **BUYER** acknowledges and agrees that the disclaimer of any liability for personal injury is a material term for this agreement and the **BUYER** agrees to indemnify the **SELLER** and to hold the **SELLER** harmless from any claim related to the item of the equipment purchased. Under no circumstances will the **SELLER** be liable for any damages or expenses by reason of the use or sale of any such equipment. The **BUYER** is responsible to obey all applicable federal, state, and local laws, statutes, and ordinances when operating his/her vehicle, and the **BUYER** agrees to hold **SELLER** harmless from any violation thereof. The **SELLER** assumes no liability regarding the improper installation or misapplication of its products. It is the installer's responsibility to check for proper installation and if in doubt, contact the manufacturer. The **BUYER** is solely responsible for all warranty issues from the automotive manufacturer.

## Limitation of Warranty

Gale Banks Engineering Inc. (hereafter "**SELLER**"), gives Limited Warranty as to description, manufacturing quality and fitness only. The **SELLER** shall be in no way responsible for the product's open use and service and the **BUYER** hereby waives all rights except those expressly written herein. This Warranty shall not be extended or varied except by written instrument signed by **SELLER** and **BUYER**.

Please see enclosed warranty information card, for warranty information regarding your product. The **SELLER** assumes no responsibility whatsoever for the **BUYER's** installation and application of the products. All products that are in question of Warranty must be returned shipping prepaid to the **SELLER** and

must be accompanied by a dated proof of purchase receipt. All Warranty claims are subject to approval by Gale Banks Engineering Inc. Under no circumstance shall the **SELLER** be liable for any labor charged or travel time incurred in diagnosis for defects, removal, or reinstallation of this product, or any other contingent expense. Under no circumstances will the **SELLER** be liable for any damage or expenses incurred by reason of the use or sale of any such equipment.

## Table of Contents

<b>General Installation Practices</b> .....	<b>2</b>
<b>General Assembly</b> .....	<b>4</b>
<b>Bill Of Materials</b> .....	<b>6</b>
<b>Section 1</b> .....	<b>7</b>
System Description	
<b>Section 2</b> .....	<b>8</b>
Component Relocation	
<b>Section 3</b> .....	<b>9</b>
Preliminary	
<b>Section 4</b> .....	<b>10</b>
Engine Valley Component Subassembly	
<b>Section 5</b> .....	<b>14</b>
Manifold Sub Assembly	
<b>Section 6</b> .....	<b>15</b>
Install Manifolds on Cylinder Heads	

# General Assembly

Figure 1

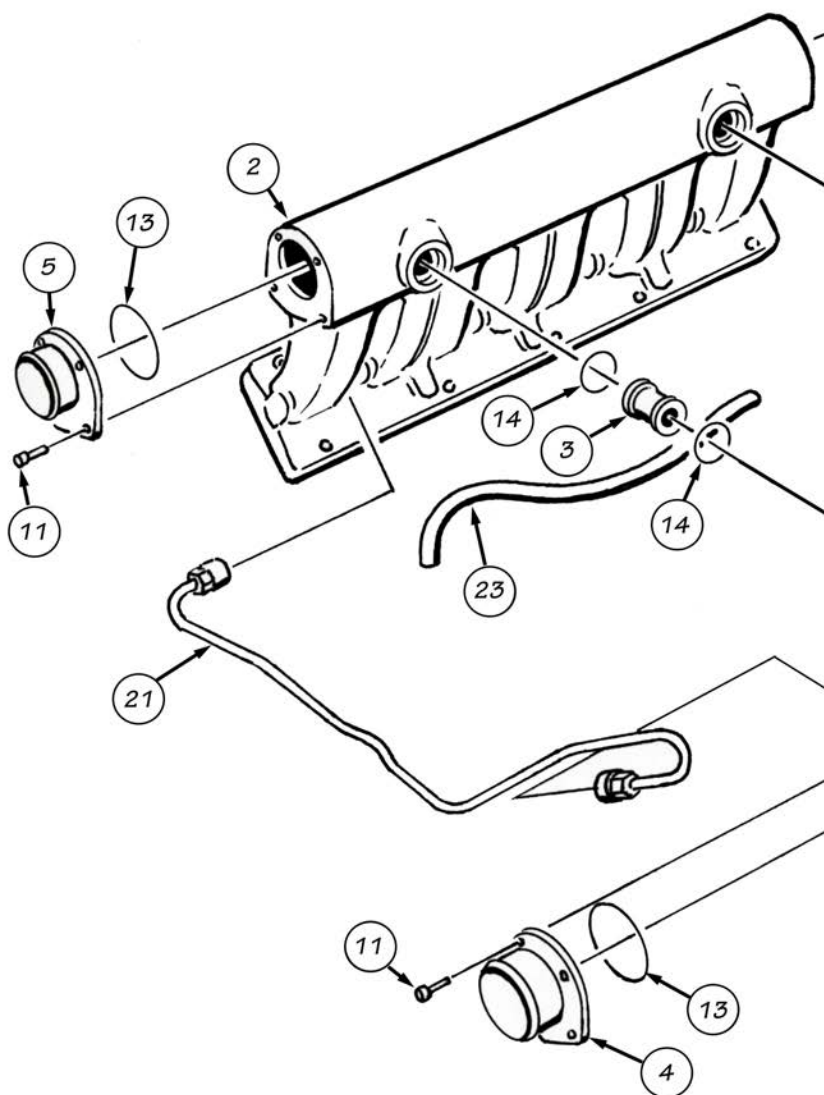

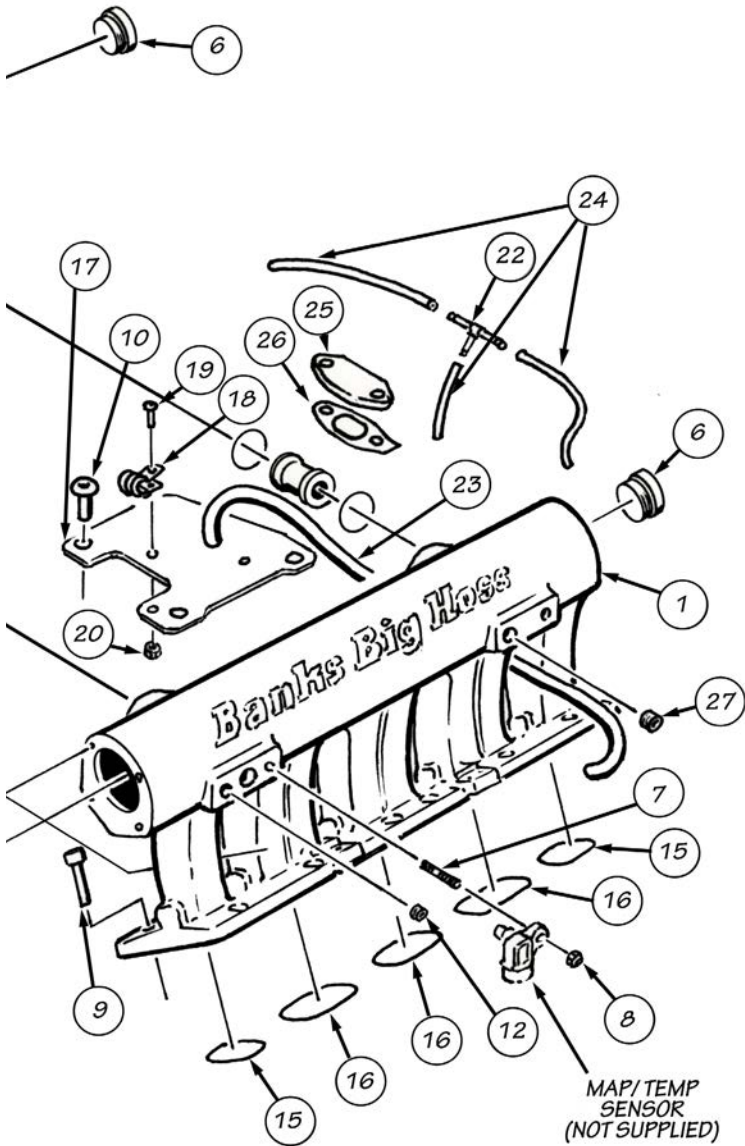

# Bill of Materials

Manifold Assembly			
Item	Description	P/N	Qty.
1	Manifold Left	42734	1
2	Manifold Right	42735	1
3	Crossover spool	42736	2
4	Manifold Inlet, Left	42752	1
5	Manifold Inlet, Right	42753	1
6	Flush head Plug	92276	2
7	Stud M6 x 1.0 x 23.5	91467	1
8	Nut, M6 x 1.0, nylock	91771	1
9	Bolts, M8 x 1.25 x 30 shcs	91558	22
10	Bolts, M12 x 1.75 x 16 button head	91572	3
11	Bolts, 1/4-20 x 3/4 shcs	91134	8
12	Pipe Plug, 1/8-27 NPT, socket head	92251	5
13	O-ring, 1/16 x 2.989 ID	93811	2
14	O-ring, 1/4 x 1.109 ID	93813	4
15	O-ring, 3/32 x 1.612 ID	93814	4
16	O-ring, 3/32 x 2.487 ID	93815	6
17	Plate, fuel Return Mount	43301	1
18	Loop Clamp, cushion	62069	3
19	Screw, 10-32 x 5/8, pan head	91869	3
20	Nut, 10 - 32 nylock	91910	3
21	Fuel Line, HPCR Crossover	43210	1
22	Barb Tee, 1/8 Hose barb	92008	1
23	Hose, 5/16 ID oil/fuel SAE 30R7	94097	1
24	Hose, 1/8 ID fuel return with fabric overbraid	94093	1
25	Plate, Oil Drain Bock-Off	24064	1
26	Gasket, Oil Drain, GM P/N 97208191	93039	1
27	Pipe Plug, 1/4 -18 NPT, socket head	92257	2

# Section 1

## SYSTEM DESCRIPTION

The Banks manifolding will increase airflow by streamlining the air entry into the cylinder head ports and providing a plenum and runner system. This allows increased performance with a given boost or even greater performance at elevated boost levels.

The Banks Big Hoss manifold is ideal for competition installations where extensive cylinder head and injection modifications are planned.

The Banks Big Hoss Intake Manifold is intended for use with custom-built twin turbo systems in which the factory turbo has been removed from the rear valley area of the engine. Because this Big Hoss Manifold System is not intended to fit a particular vehicle or chassis, design and fabrication of all turbo and accessory mount components, as well as turbo selection, is up to the installer.

-END, SECTION 1-

# Section 2

## COMPONENT RELOCATION

Installing the Banks Big Hoss Intake Manifolding requires relocating the turbochargers and all intake, exhaust and cooling system components from the top of the engine. The coolant outlet tube, oil fill tube, crankcase breathers, fuel lines, belt driven engine accessories, wires looms and other components will have to be modified and/or

relocated to accommodate the Banks Big Hoss manifold. A shop manual should be consulted as necessary for information regarding the disassembly, assembly and safety of fuel injection and other engine components.

-END, SECTION 2-



# Section 3

## PRELIMINARY

This manifold installation procedure assumes that the cylinder heads are assembled with all port and valve work completed, and are installed and torqued, ready for manifold installation. Because of the custom nature of this application, the installer should test fit all components and related systems prior to performing a final assembly of the intake manifolding. If the original coolant outlet/thermostat housing "Y" casting is to be retained, modifications to this casting and the thermostat cover will need to be considered to clear the manifold castings.

Once the manifold castings are bolted in place, it becomes somewhat difficult to access and make system connections under the plenums in the valley area. Preplan your work and make as many of your required system connections in the valley before installing

the manifold halves. Pre-assemble and install any fuel and oil hoses that tie outside components to the valley area.

The fuel injection pump should be installed along with inlet and return adapter fittings in the pump ports. Injectors should be installed in the cylinder heads.

Install a turbocharger oil supply adapter fitting (not supplied) in the boss in the engine valley along with any related plumbing (hose with divider "T" and branch lines to provide oil to the turbochargers) as this area becomes inaccessible once the manifolds are installed. Fitting or hose end used for oil supply should be a 90° elbow style to point forward to clear fuel return cluster panel.

-END, SECTION 3-

**Figure 2**

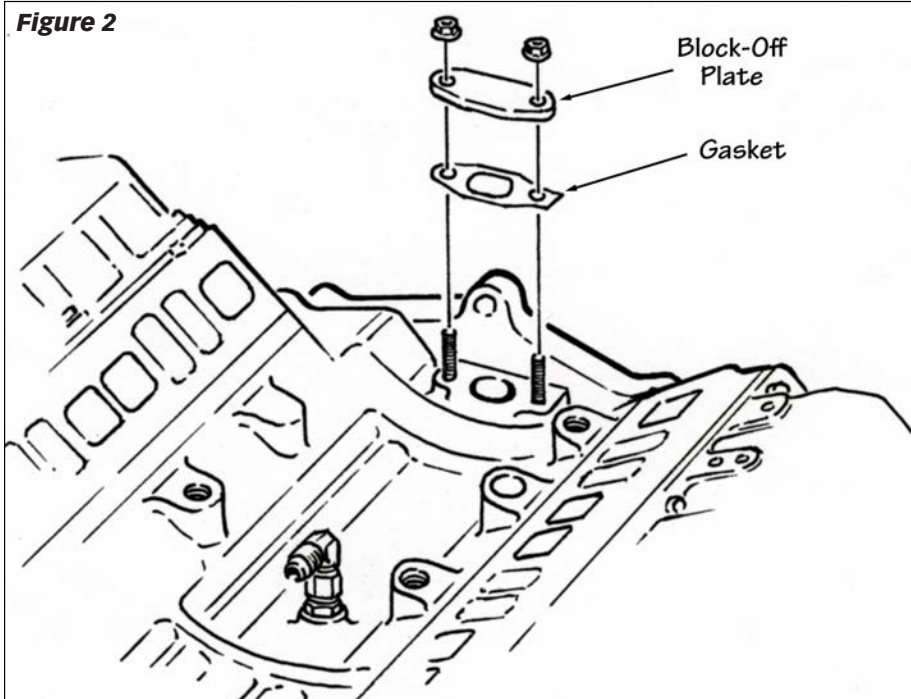

# Section 4

## ENGINE VALLEY COMPONENT SUBASSEMBLY

1. Install oil return block-off plate and gasket over original oil return port at rear of valley area if the port is not used. Secure with original M8 studs and nuts. See **Figure 2**.

2. Identify factory fuel return line tube cluster with fuel temperature sensor. Using a tubing cutter, cut and discard the fuel pump return line with the "T" as shown. See **Figure 3**. With

**Figure 3**

CUT LINE

FORM BARB ON  
CUT END OF TUBE

$1 \frac{7}{8}$

FRONT  
OF ENGINE

RETURN LINE  
MAY BE BENT  
REARWARD IF  
DESIRED

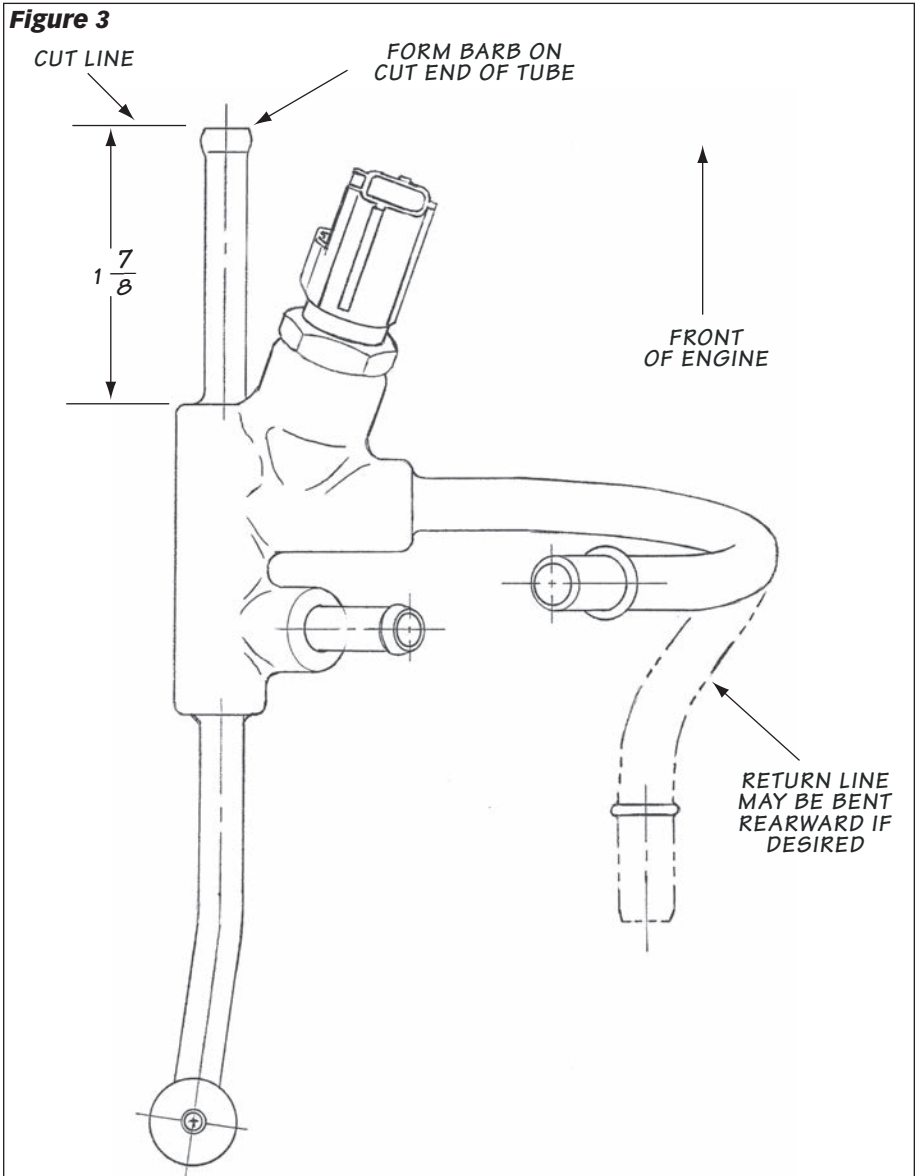

the sensor removed, Deburr cut end of tube on the cluster, rinse assembly with solvent and blow dry. Reinstall sensor

**3.** Using a 45° double flaring tool, perform the first operation of a 5/16"

tube dia. double flare on the cut end of the pump return tube. Compress the tube with the flaring tool just enough to create a "bulge" to act as a hose barb so a 5/16" dia. hose may be installed and clamped.

**Figure 3**

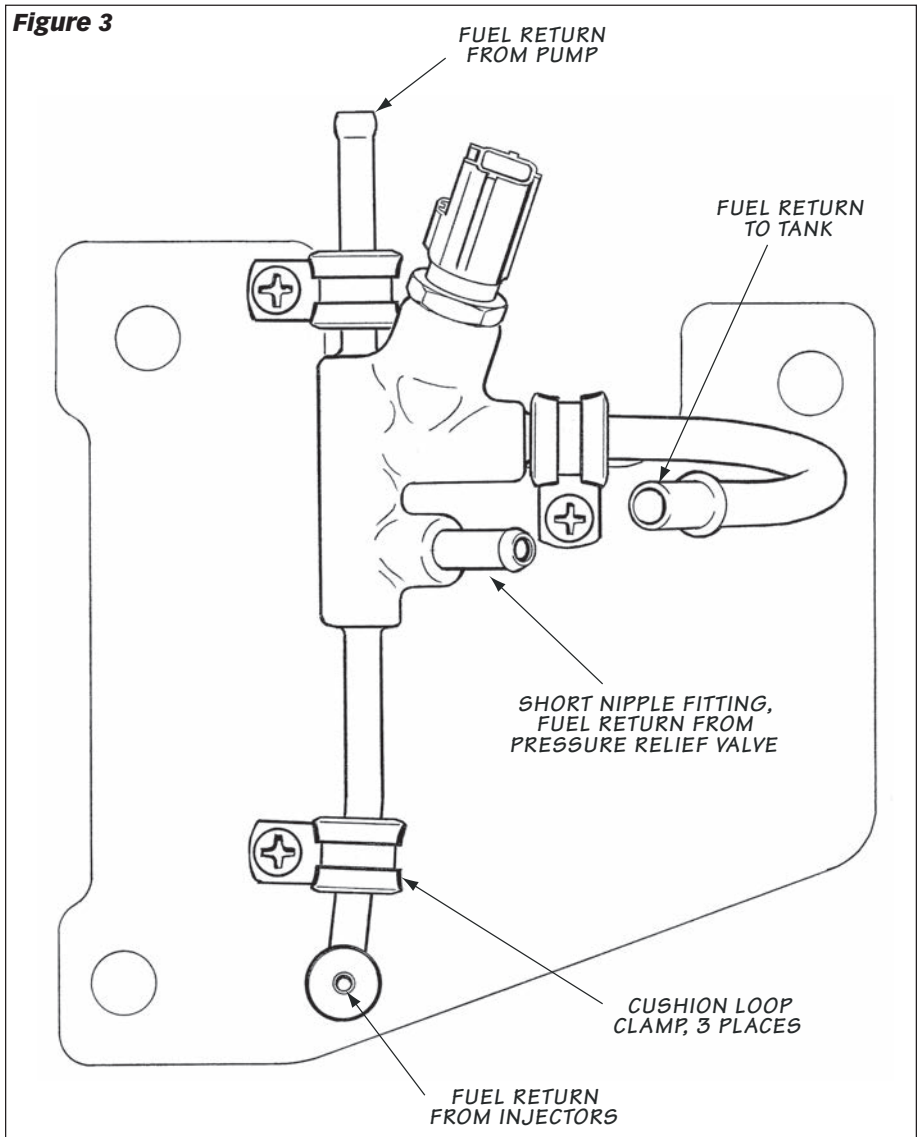

**4.** Mount fuel return line tube cluster to support panel using three 10-32 x  $\frac{5}{16}$  pan head screws, 10-32 Nylock nuts, and  $\frac{3}{8}$  I.D. cushion loop clamps. See **Figure 4**.

**5.** Install assembled support panel in rear of engine valley on existing turbo mounting bosses using three M12 x 1.75 x 16 mm button head socket screws.

**6.** Cut and install a  $\frac{5}{16}$ " dia. by 18-inch long fuel hose between the return fitting on top of the fuel pump and the return cluster tube that was cut. Re-use two spring-band clamps from the original fuel return hose assembly and slide over fuel hose. Clamp into place. See **Figure 5** and **6**.

**7.** Install one end of the remaining  $\frac{5}{16}$ " dia. fuel hose on the short nipple fitting on the fuel return cluster using another original fuel return spring band clamp. See **Figure 5**.

**8.** Cut a 3" long piece of  $\frac{1}{8}$ " dia. fuel hose and install it on the  $\frac{1}{8}$ " dia. hose nipple on the fuel return tube cluster. See **Figure 5**.

**9.** Install the side nipple of a  $\frac{1}{8}$ " plastic barb tee in the 3" piece of hose installed in the previous step. See **Figure 5** and **6**.

-END, SECTION 4-

**Figure 5**

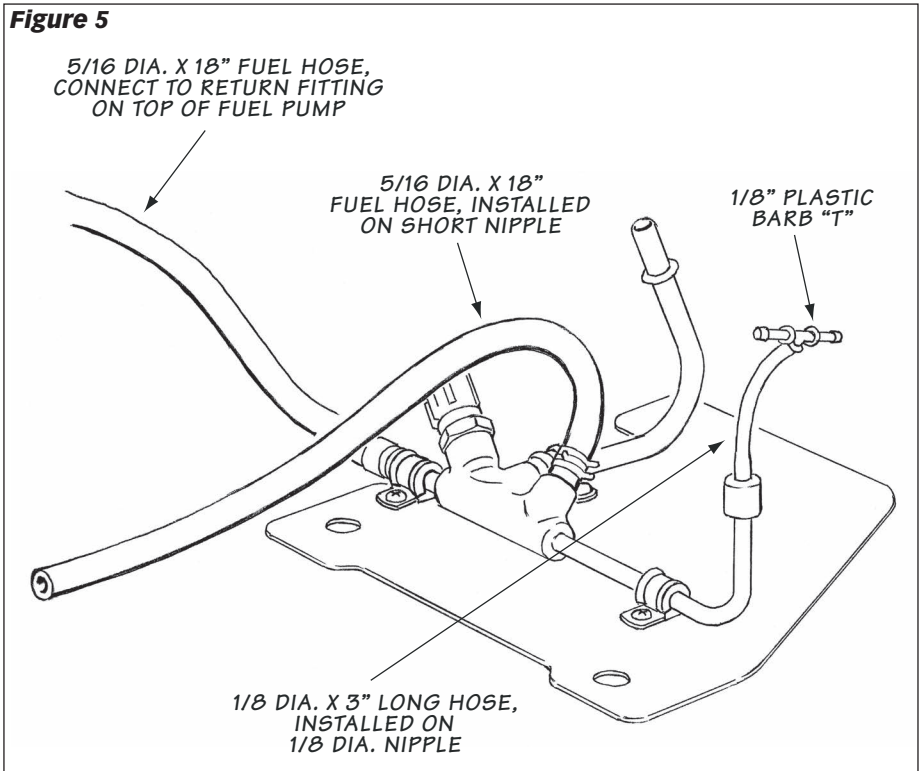

**Figure 6**

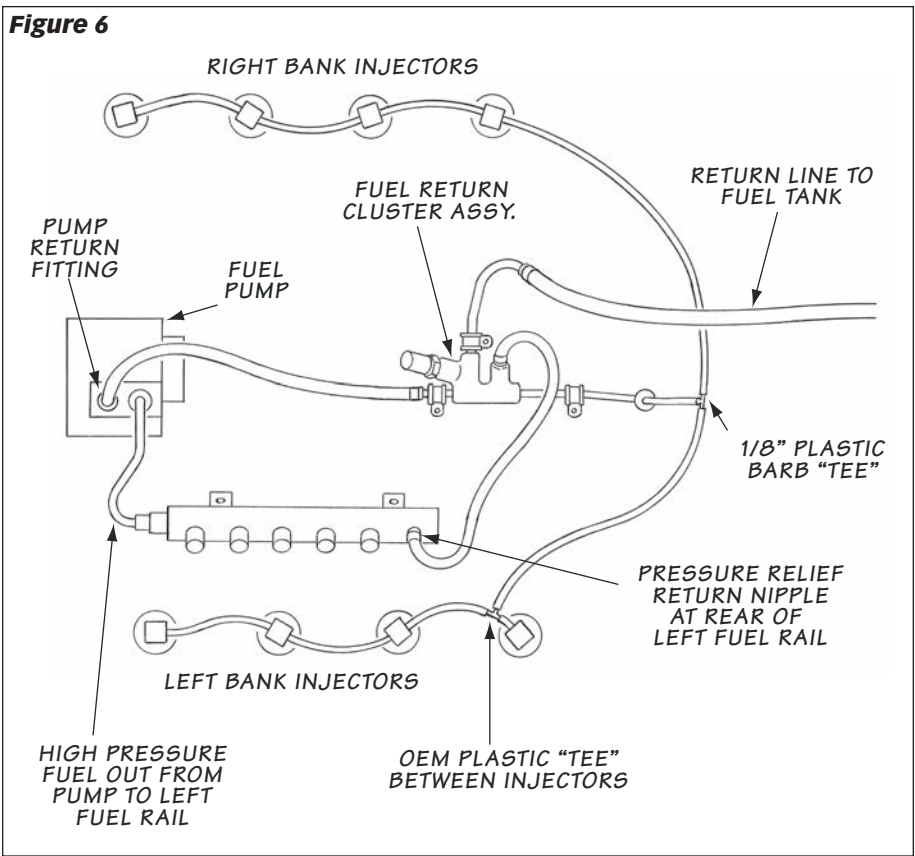

# Section 5

## MANIFOLD SUB ASSEMBLY

- 1.** Inspect manifolds for any chips or debris that may have been left from machining or handling. Spray inside of manifolds with parts cleaners or solvent if required.
- 2.** Lightly oil the o-rings on two- 20 SAE socket head hydraulic plugs and install a plug in the back end of each of the manifold castings. Tighten the plugs using a  $\frac{3}{4}$  inch Allen wrench. See **Figure 7**.
- 3.** Install an M6 x 1.0 x 24mm stud in the front plenum boss on the left hand manifold. Apply Loctite to the short

thread end of the stud and tighten into the manifold. See **Figure 7**.

- 4.** Install left and right inlet nipple flanges and  $\frac{1}{16}$  x 2.989 I.D. o-rings to the front of each manifold using four  $\frac{1}{4}$ -20-x  $\frac{3}{4}$  socket head cap screws per flange. A small dab of gasket sealant or RTV may be used to hold o-ring in place during assembly.

*NOTE: Suggest using Dow-Corning No. III valve lubricant with silicone.*

-END, SECTION 5-

# Section 6

## INSTALL MANIFOLDS ON CYLINDER HEADS

*NOTE: Normally manifolds install with their inlet flanges facing forward, however they may be reversed for special applications.*

**1.** Two balance tube spools with o-ring seals interconnect the manifold plenums. These spools are supplied blank (no drilled thru-hole) and may be drilled out as desired. Different turbocharger performance characteristics may require different balance hole sizes to dampen intake pulsation and maintain the same boost levels in both banks of the engine. We suggest you start by drilling a  $\frac{1}{2}$  diameter hole through each spool and enlarge the hole if testing dictates.

**2.** Install two  $\frac{3}{32}$ " x 1.612" diameter and three  $\frac{3}{32}$ " x 2.487" diameter o-rings in the grooves on each manifold mounting flange. The small o-rings go in the grooves around the end runners of each manifold.

*NOTE: Dow-Corning III, or a small dab of gasket sealant or RTV may be used to hold the o-rings in place in the manifold flange grooves. See **Figure 7**.*

**3.** Install two  $\frac{1}{8}$ " x 1.109" diameter o-rings in the grooves on each balance tube spool. Apply a light oil on all four o-rings and insert both balance tubes into the machined bosses on one of the two manifold plenums. See **Figure 7**.

**4.** Engage the free ends of the balance tube spools into the bosses on the opposite side manifold and push the manifolds together until the spools seat in the manifolds. Carefully set the paired manifolds on the cylinder head faces while guiding loose fuel and oil lines through the openings between the manifold runners. This works best with an assistant helping. See **Figure 7**. Check that the o-rings stayed in place.

**5.** Install eleven M8 x 1.25 x 30mm socket head bolts through each manifold base flange into heads. Leave bolts finger tight. Balance tube spools will be free to slide within their bores, but not to the extent that their o-rings will not seal.

**6.** Tighten the bolts on the right hand manifold first. A ball-drive hex wrench and L-hex wrench work best in tight places. An 8mm box wrench around the shaft of a long 8mm ball handle can be used to feed through the runners on the manifolds for more torque. Once the right manifold bolts are tight, tighten the left side.

**7.** Install the right and left fuel rails on the intake manifold base flanges using the original M8 bolts. Fuel rails mount on the rear set of the double bolt pattern. The right hand rail has the fuel pressure sensor.

**8.** Install the new high-pressure fuel crossover line by feeding it through the opening just behind the front-runners on each manifold. Thread the tube nuts onto each fuel rail, and leave the nuts finger tight. The tube may be bent slightly if necessary to line up the end connections. See **Figure 1**.

**9.** Install the original high-pressure fuel line between the outlet connections on top of the fuel pump and front of the left hand fuel rail. The line feeds through the opening behind the front-runner on the left hand manifold and under the crossover fuel line. The line must be reversed end-for-end to clear the manifold runners. Tighten the tube nuts on both fuel lines. It may be easiest to loosen the nuts and disengage the ends of the long fuel line before first tightening the short line, then the long line.

Figure 7

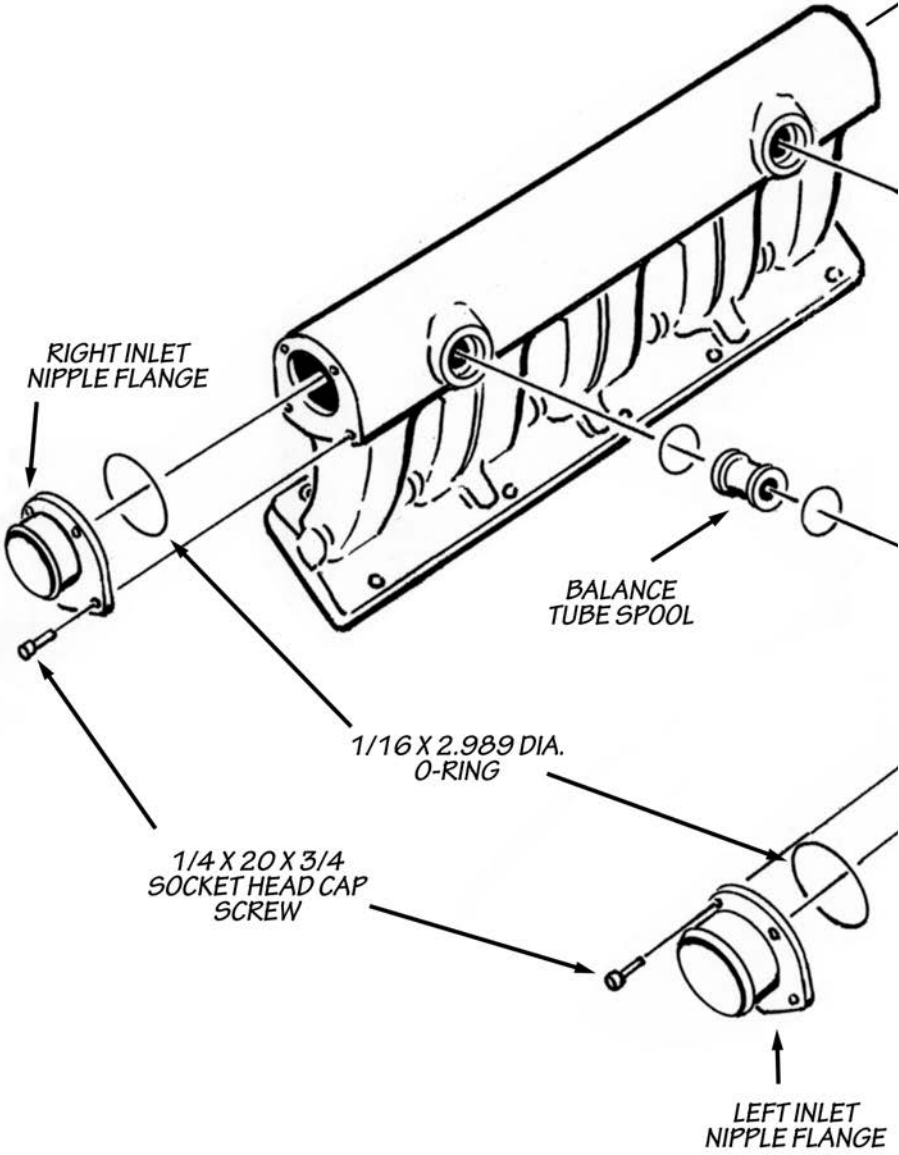



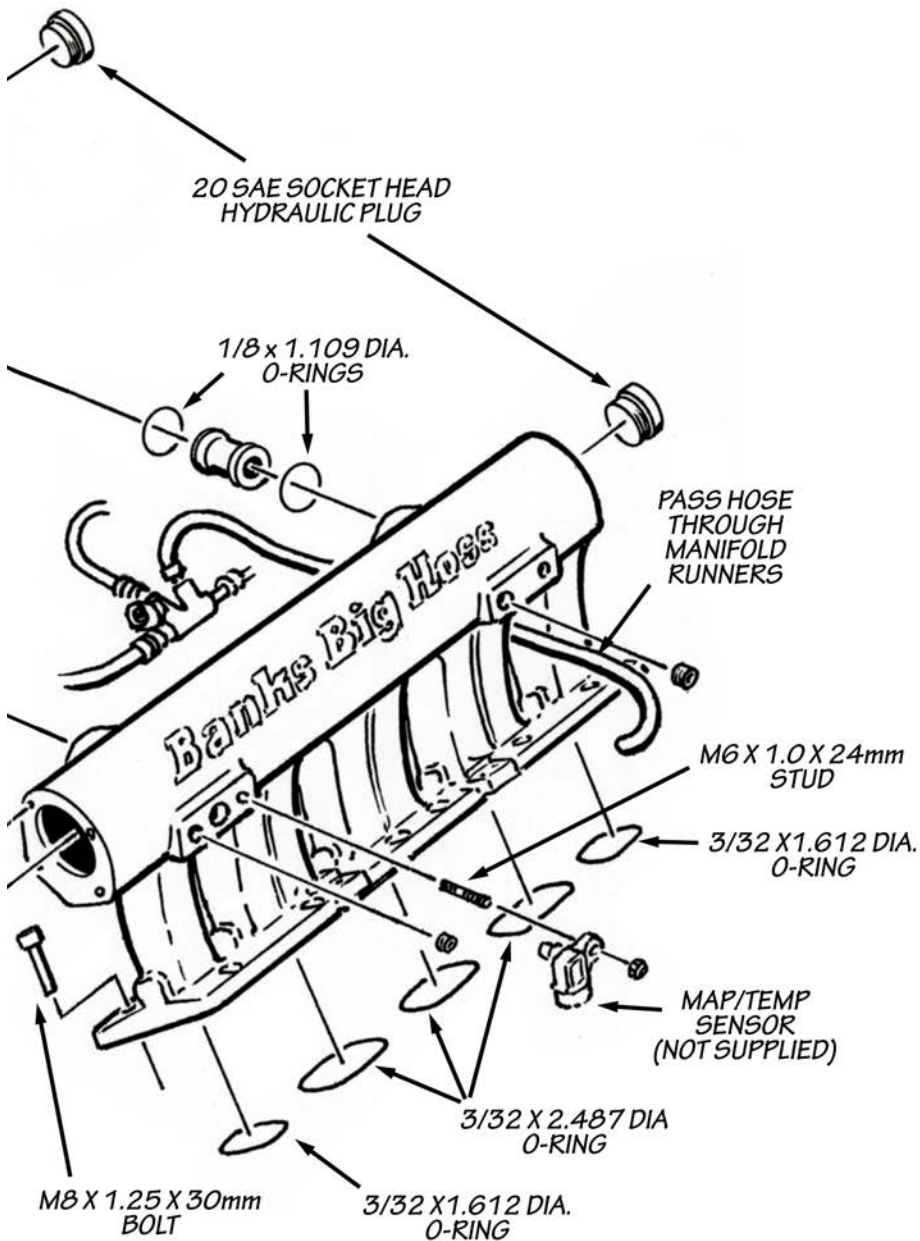

**10.** Reinstall the high-pressure fuel lines from the fuel rails to the injectors.

**11.** Install the free end of the  $\frac{5}{16}$ " dia. fuel return hose onto the relief valve outlet nipple at the rear of the left hand fuel rail. Pass the hose through the opening between the runners at the rear of the manifold and secure the hose with an original fuel return spring band clamp. See **Figure 7**.

**12.** Install the fuel return line assemblies and clips on the tops of the injectors. Reverse the line assembly on the right bank injectors and reinstall it so the common outlet line is at the rear of the engine. Use the remaining  $\frac{1}{8}$ " dia. hose to join the common outlets of all the injectors to each side of the  $\frac{1}{8}$ " plastic barb "T" at the rear of the fuel line return cluster. See **Figure 6**.

**13.** Apply a small drop of light oil to the o-ring on the MAP sensor (not provided) and push sensor into the bore at

the front boss pad on the left manifold plenum. Secure the sensor by installing an M6 Nylock nut on the stud. See **Figure 7**.

*NOTE: Some sensors may require bending the sensor mount tab to allow installation of the nut.*

**14.**  $\frac{1}{8}$ " and  $\frac{1}{4}$ " NPT pipe threads are provided at the front and rear boss pads on each manifold plenum. These may be used for wastegate actuation lines or other boost referenced components such as a boost gauge. Install  $\frac{1}{8}$ " or  $\frac{1}{4}$ " NPT socket head pipe plugs in any unused boost reference ports.

**15.** Connect sensor leads to fuel return temp sensor in engine valley and MAP sensor. Reroute wire loom leads as required to fit your installation.

This concludes the intake manifold installation on the engine.

-END, SECTION 6-