

**banks**<sup>®</sup>

with Installation Instructions  
**Owner's Manual**

**Banks Ram-Air<sup>®</sup>  
Super-Scoop<sup>®</sup>**

**2007-2013 Chevy/GMC Pickups**

THIS MANUAL IS FOR USE WITH SYSTEM 42235, 42236 & 42237

**banks**

Dear Customer,

If you have any questions concerning the installation of your Banks Ram-Air® Super-Scoop®, please call our Technical Service Hotline. If you have any questions relating to shipping or billing, please contact our Customer Service Department.

Thank you.

## General Installation Practices

1. For ease of installation of your Banks Ram-Air Super-Scoop, familiarize yourself with the procedure by reading the entire manual before starting work. This manual contains 16 pages of copy, illustrations and parts listing. If any pages are missing from this manual please call Gale Banks Engineering immediately for a replacement.

2. The exploded view of the Ram-Air Super-Scoop assembly (page 3) provides only general guidance. Refer to each step and section diagram in this manual for proper instruction.

3. Throughout this manual, the left side of the vehicle refers to the driver's side, and the right-side to the passenger's side.

4. Disconnect the ground cable from the battery before beginning work. If there are two batteries, disconnect both.

5. Route and tie wires and hoses a minimum of 6 inches away from exhaust heat, moving parts and sharp edges. Clearance of 8 inches or more is recommended where possible.

6. During installation, keep the work area clean. If foreign debris is transferred to any Banks system component, clean it thoroughly before installing.

7. When raising the vehicle, support it on properly weight-rated safety stands, ramps or a commercial hoist. Follow

the manufacturer's safety precautions. Take care to balance the vehicle to prevent it from slipping or falling. When using ramps, be sure the front wheels are centered squarely on the topsides; put the transmission in park; set the parking brake; and place blocks behind the rear wheels.

**⚠ WARNING:** **DO NOT USE FLOOR JACKS TO SUPPORT THE VEHICLE WHILE WORKING UNDER IT. DO NOT RAISE THE VEHICLE ONTO CONCRETE BLOCKS, MASONRY OR ANY OTHER ITEM NOT INTENDED SPECIFICALLY FOR THIS USE.**

**NOTICE:** *This product is intended for general highway use. Do not use this product when fording streams or crossing bodies of water. Although this product is designed to separate water from entering the engine during normal highway driving in rainy conditions, it is not intended to be submerged under water for any amount of time. Regularly check the inlet of the Super-Scoop for any obstruction or debris that may impede the flow of air. After the installation of the Super-Scoop be aware of the decreased ride height and drive accordingly to avoid damage to the Super-Scoop. Regularly check to make sure the Super-Scoop is fastened securely and that all hardware and fasteners are tight and in good condition.*

## Definitions of ANSI Z535 Safety Standards

**⚠ DANGER:** Indicate[s] a hazardous situation which, if not avoided, **will result in death or serious injury.**

**⚠ WARNING:** Indicate[s] a hazardous situation which, if not avoided, **could result in death or serious injury.**

**⚠ CAUTION:** Indicate[s] a hazardous situation which, if not avoided, **could result in mild or moderate injury.**

**NOTICE:** Indicate[s] a situation that requires your immediate attention.

## Tools Required

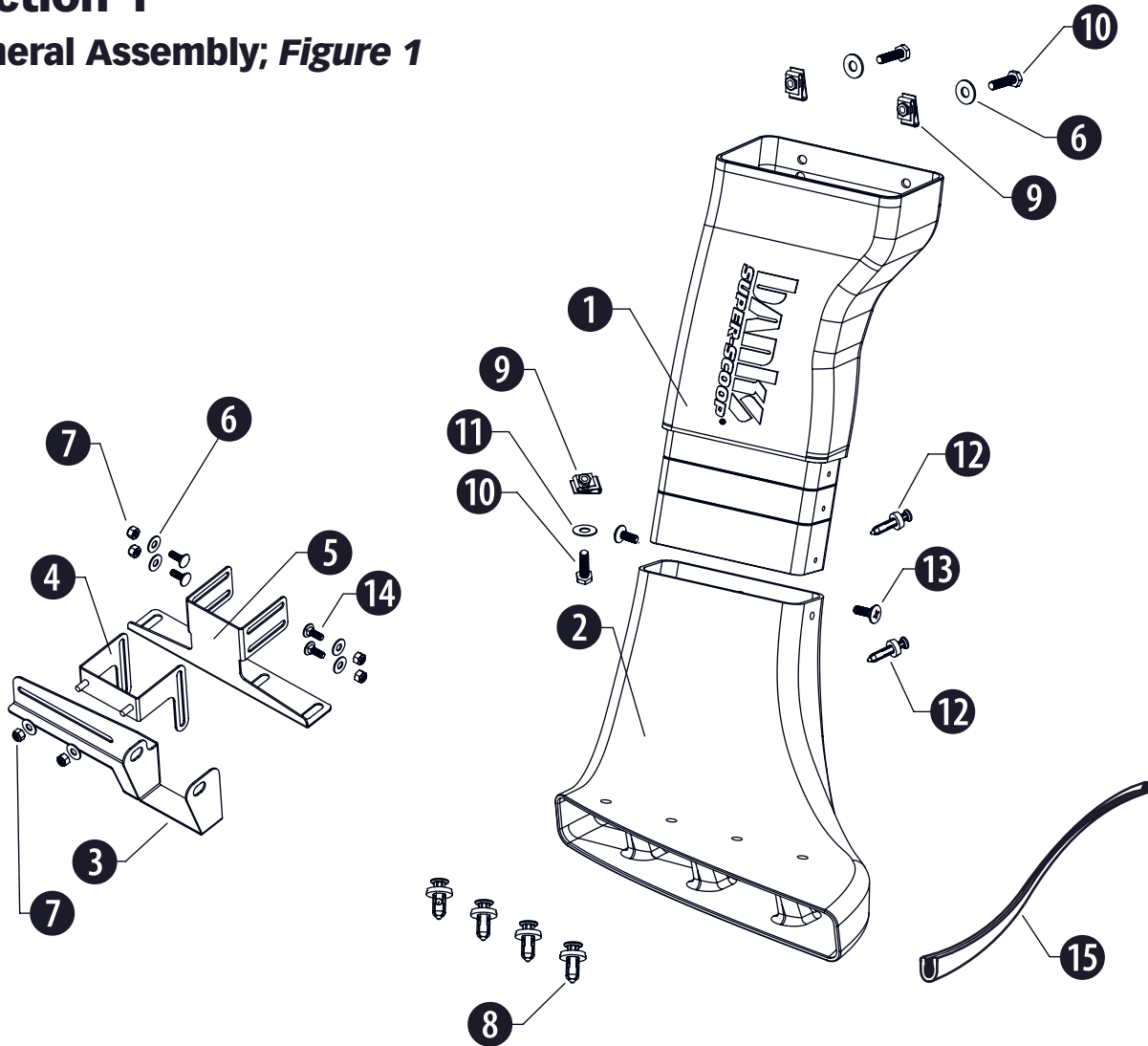
- $\frac{3}{8}$ " drive ratchets with metric sockets .....
- Standard and Phillips head screwdrivers .....
- Standard and needle-nose pliers .....
- Clean shop towels or rags .....
- Electric Drill .....
- Drill Bits:  $\frac{1}{8}$ ",  $\frac{3}{8}$ ",  $\frac{1}{4}$ ",  $\frac{5}{16}$ " .....
- Utility knife.....
- Permanent marker .....

### **NOTICE:**

*The Super-Scoop kit is designed to work on vehicles with factory sized wheels/tires. Running oversized wheels/tires may cause interference between the tire and Super-Scoop. Also, please be aware that fender lining and/or bumper valance trimming is required for this kit.*

# Section 1

## General Assembly; Figure 1



Item	Description	Part#	Qty
1.	Super-Scoop, Ram-Air System, Upper	42231	1
2.	Super-Scoop, Ram-Air System, Lower	42232/42233	1
3.	Bracket, Upper, Super-Scoop	42208	1
4.	Bracket, Middle, Super-Scoop	42207	1
5.	Bracket, Lower, Super-Scoop	42206	1
6.	Washer, USS, Zinc, 1/4	91103	8
7.	Nut, Nylock, 1/4-20 UNC	91110	6
8.	Retainer, Push-Type, 20mm Head X 10mm Dia.	92023	4
9.	Nut, Clip-On, M6 X 1.0	91712	3
10.	Hex Bolt, Zinc, 6mm X 1.0 X 25mm	91742	3
11.	Washer, SAE Flat, Zinc, 1/4	91102	1
12.	Retainer, Push-Type, 11/16" Head X 1/4" Dia.	92020	2
13.	Machine Screw, Truss Hd, Phil – 1/4-20 X 5/8"	91129	2
14.	Bolt, Carriage – 1/4-20 X 3/4"	91135	4
15.	Edge Trim	93142	1

\* Replace when nylon insert is worn and is no longer self-locking.

\*\* Replace when nut is worn and is no longer self-locking.

**If your vehicle does not have tow hooks equipped, you will need the following additional hardware:**

1.  $\frac{7}{16}$ "-14 x 4  $\frac{1}{2}$ " Hex Bolt, Quantity 1
2.  $\frac{7}{16}$ "-14 Flange Nut, Quantity 1

## Section 2

### Super-Scoop Installation

**NOTICE:** Before installing the Banks Super-Scoop make sure to have a completely installed Banks Ram-Air Intake System in your vehicle.

1. Remove all plastic retainer pins and screws attached to the fender lining, then remove the wheel liner and set aside. See **Figure 2**.

**NOTICE:** Skip to step 11 for MY2010-13 or 1500

2. Remove the wheel liner support bracket plastic retainers and detach the wire harness clip. See **Figure 3**.

3. Use Template 1 (page 8) to place over the support bracket tab as shown in **Figure 4**. Center punch the marked hole on the template.

4. Drill a pilot hole over the marked location with a 1/8" drill bit. Finish drilling with a 3/8" drill bit.

5. Clean the hole and install a supplied Clip-On-Nut over the hole. Install the Clip-On-Nut so that the nut is positioned facing up on the support bracket. See **Figure 5**.

6. Loosely install the wheel liner support bracket and slide the bracket to the left so that the upper tab is in contact with the vehicle's frame member.

7. Place Template 1 (page 8) over the bottom edge of the vehicle frame member as shown in **Figure 6**. Make sure that the edge of the support bracket is in contact with the vehicle frame member.

8. Center punch the marked hole on the template. Remove the Support Bracket. Drill a pilot hole over the marked location with a 1/8" drill bit. Finish drilling with a 5/16" drill bit. See **Figure 7**.

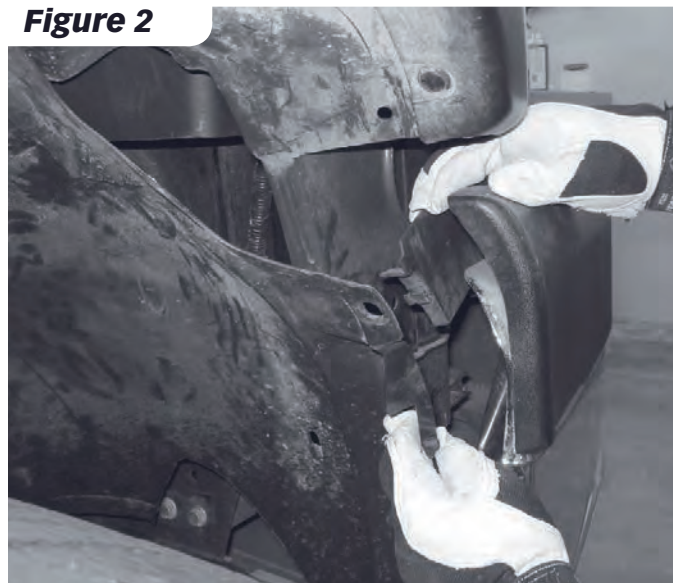
**NOTICE:** Only drill through the bottom of the vehicle's frame member.

9. Cut the support bracket as shown in **Figure 8**.

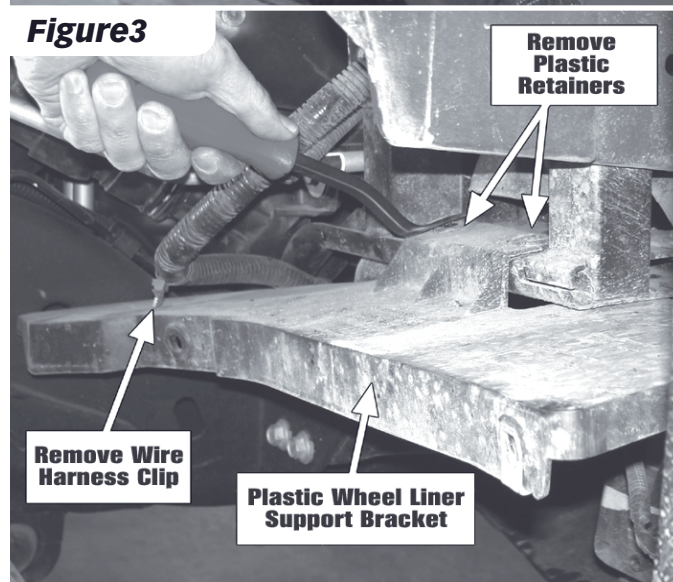
10. Take the cut support bracket with the installed Clip-On-Nut and install into the vehicle's frame member. Use the supplied bolt and washer to fasten the support bracket to the vehicle's frame member. See **Figure 9**. Tighten the bolt till snug.

11. For MY 2010-13 2500HD, Remove two nuts and remove the splash guard with the wheel liner. Re-install nuts back onto studs to secure the valance. See **Figure 10**. Cut the horizontal portion of the wheel liner with splash guard as shown in **Figure 11**.

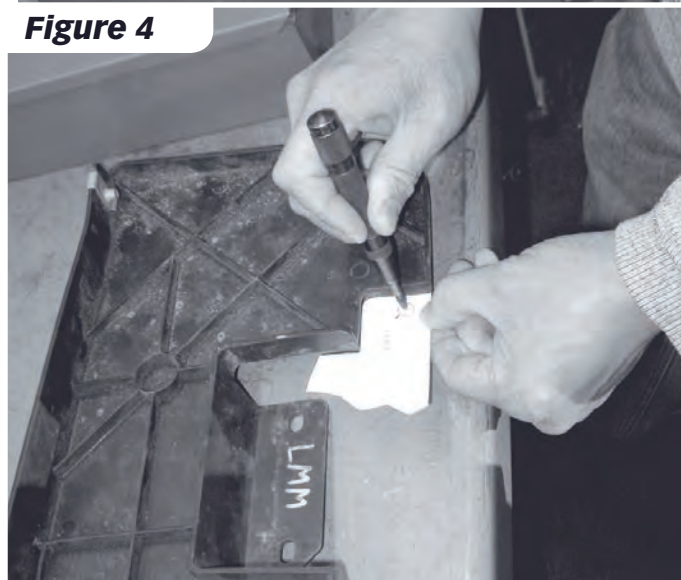
**Figure 2**



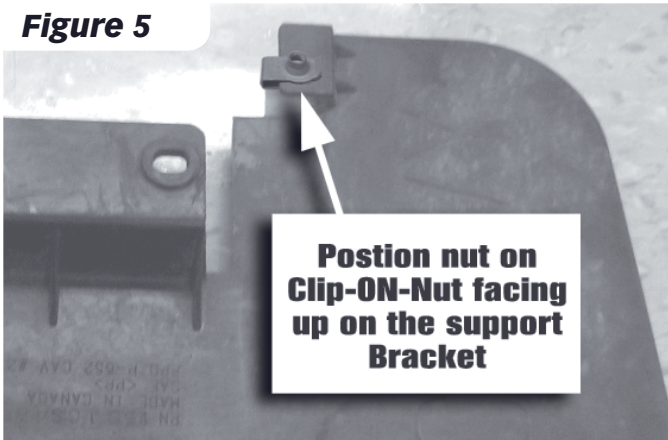
**Figure 3**



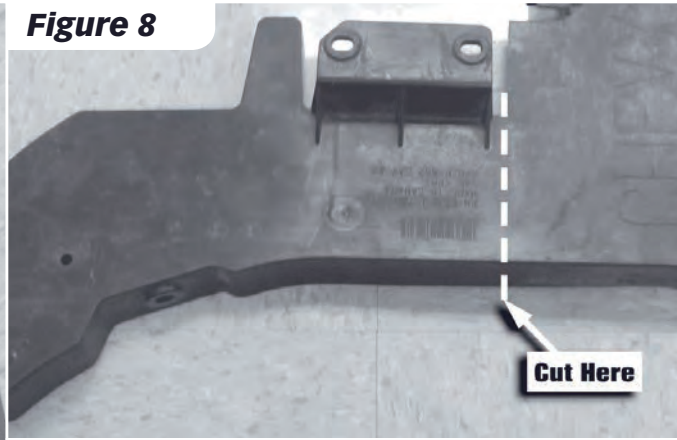
**Figure 4**



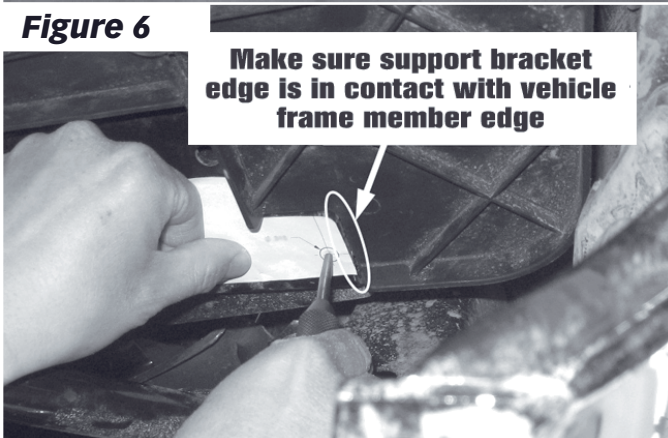
**Figure 5**



**Figure 8**



**Figure 6**



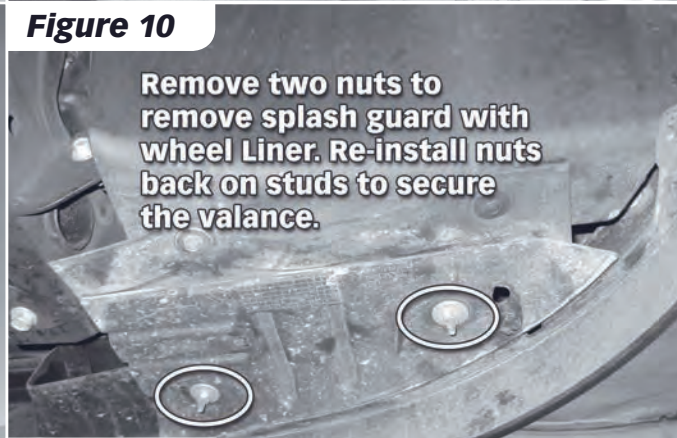
**Figure 9**



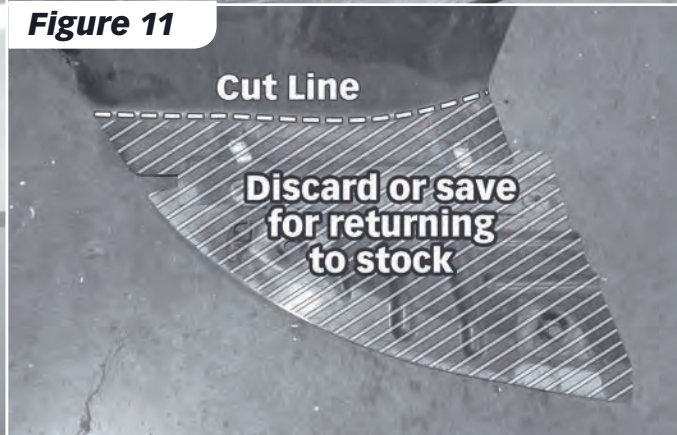
**Figure 7**



**Figure 10**



**Figure 11**



**12.** For 1500 models, remove the wheel liner support bracket plastic retainer and the bolt. Discard the support bracket plastic. See **Figure 12 & Figure 13**.

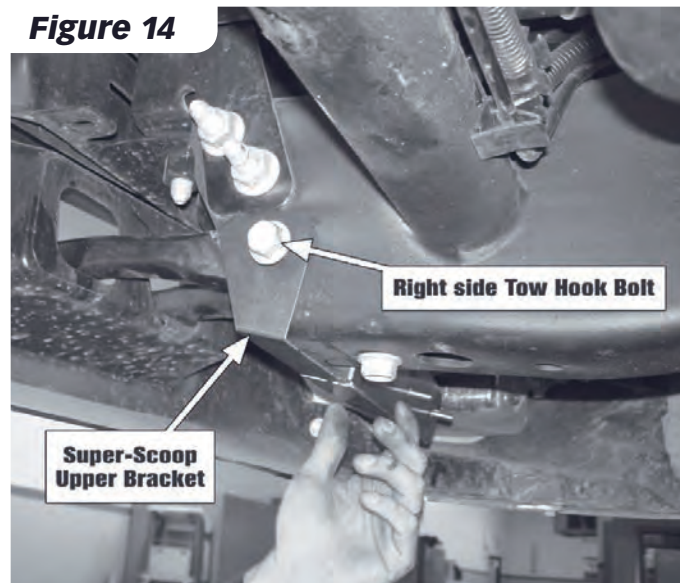
**13.** From under the vehicle remove the right side tow hook bolt to install the Super-Scoop upper bracket.

**14.** Locate the Super-Scoop Upper bracket and install over the tow hook using the previously removed bolt. See **Figure 14**. Tighten the right side tow hook bolt to 52 ft-lbs and securely fasten the Upper Bracket to the vehicle frame. See **Figure 14**. Access the tow hook bolt from the tow hook opening. See **Figure 15**.

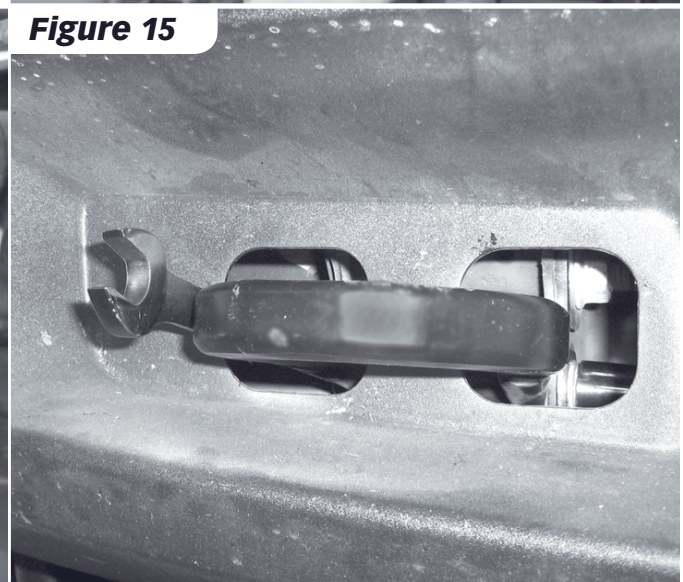
**15.** Trim the lower section of upper Super-Scoop per your vehicle model. See **Figure 16**.

MY 2007-2013 1500: **Trim 1**  
MY 2007-2010 2500HD: **Trim 2**  
MY 2011-2013 2500HD: **No trimming**

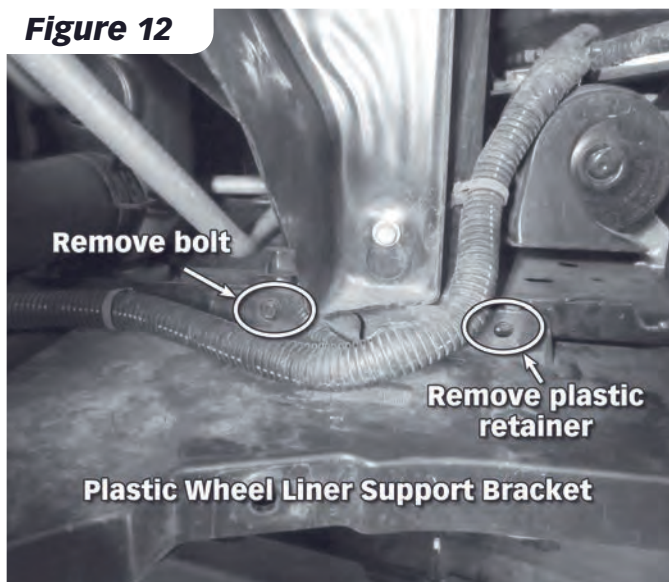
**Figure 14**



**Figure 15**



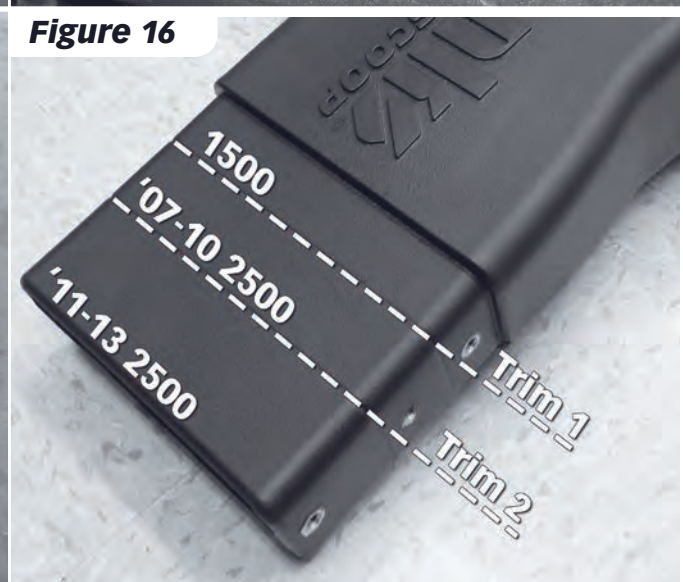
**Figure 12**

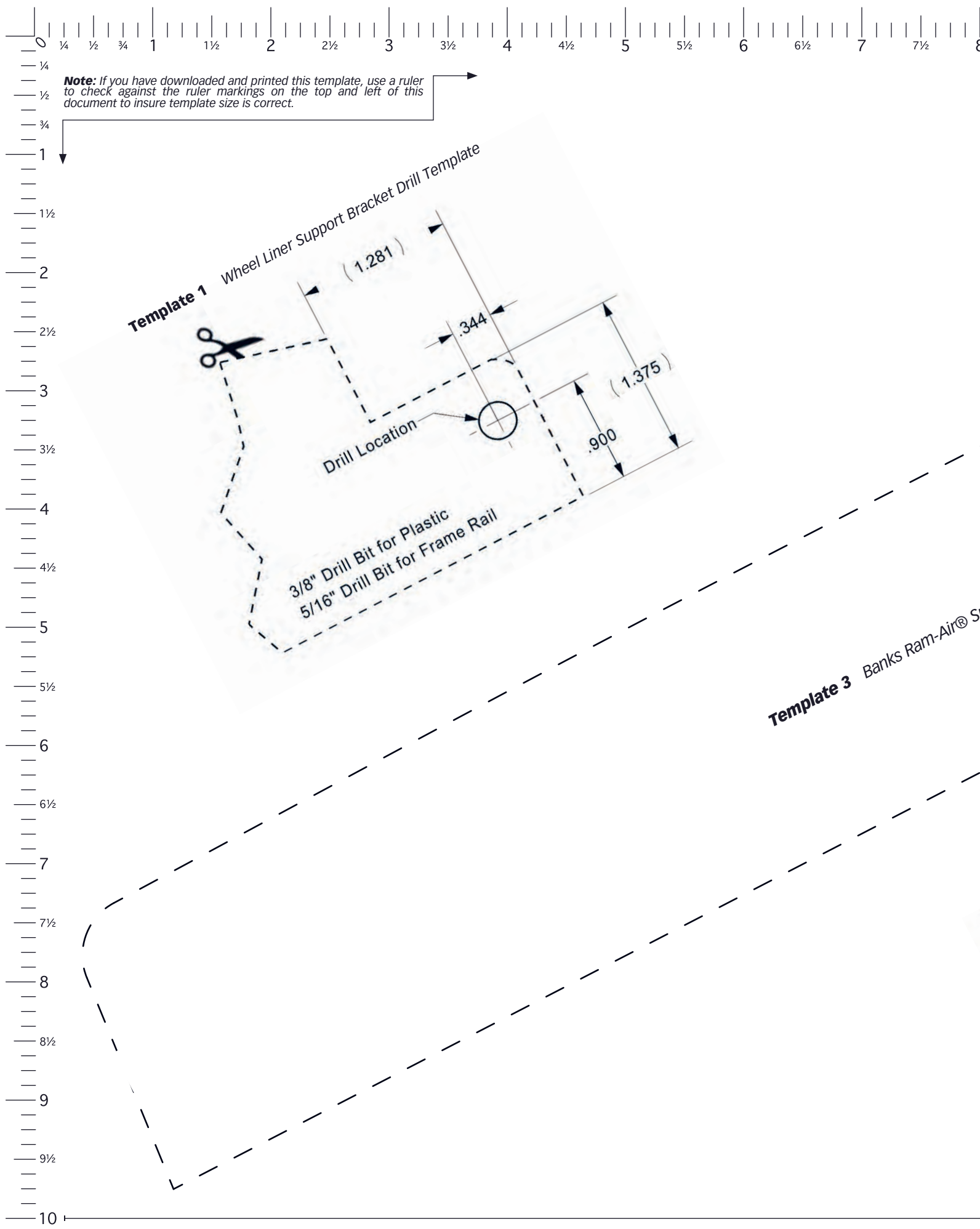


**Figure 13**



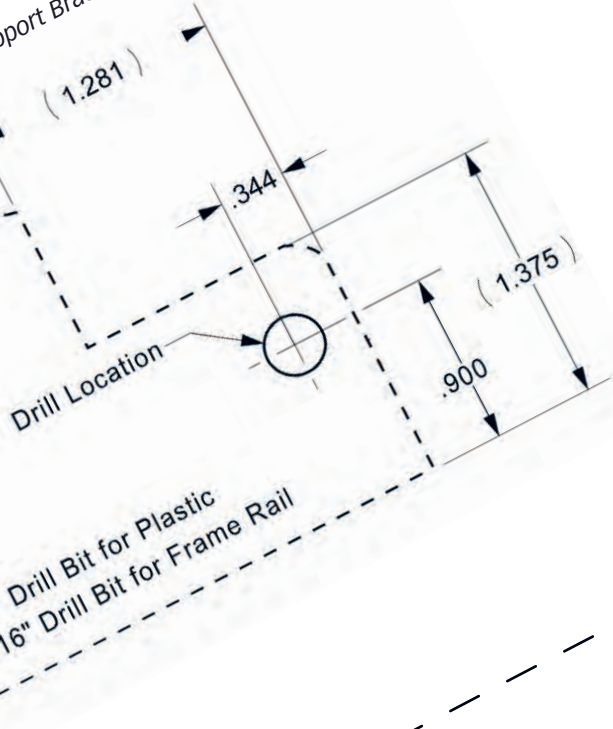
**Figure 16**





**Note:** If you have downloaded and printed this template, use a ruler to check against the ruler markings on the top and left of this document to insure template size is correct.

**Template 1** Wheel Liner Support Bracket Drill Template



**Template 3** Banks Ram-Air® S



uper-Scoop® Hood Cut Template



**Template 2** Ram-Air Box Drill Template

BOTTOM EDGE OF  
BOX DOWNSPOUT

3/8" Drill Location

.530

4.50





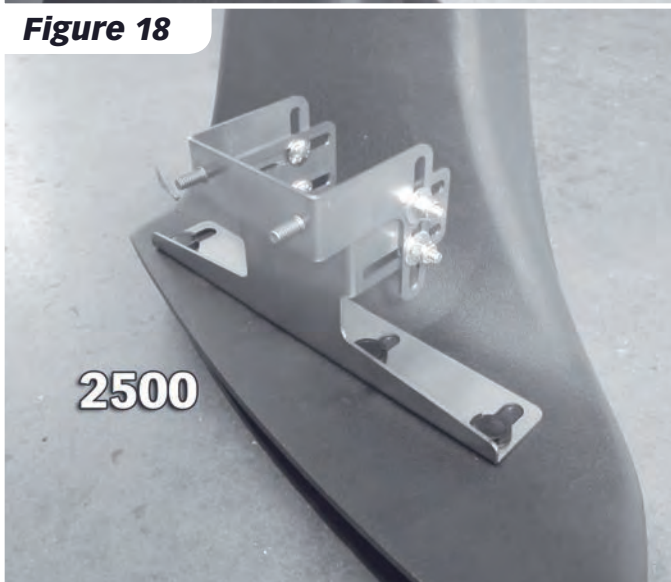
**Figure 17**



**Figure 20**



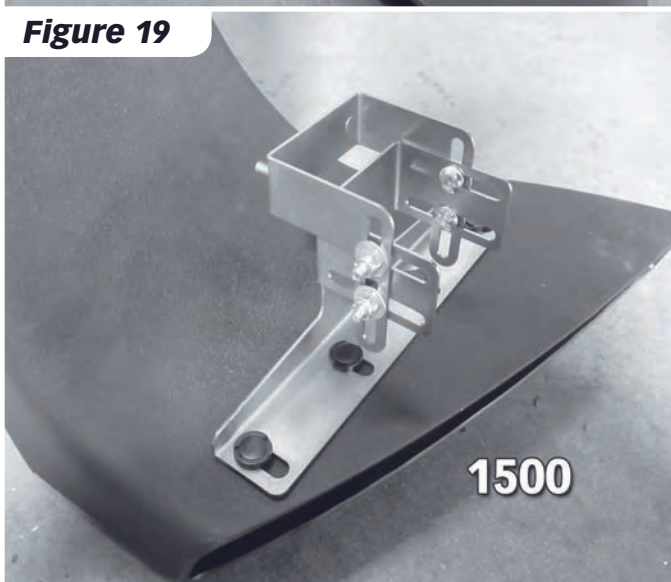
**Figure 18**



**Figure 21**



**Figure 19**



**16.** Assemble upper and lower halves of Super-Scoop using two truss head phillips screws. See **Figure 17**.

**17.** Locate the supplied middle and lower bracket, and plastic push-in retainers.

**18.** Assemble middle and lower brackets per your vehicle model.

2500HD – See **Figure 18**.

1500 – See **Figure 19**.

**19.** Position the bracket assembly over the slots on the Super-Scoop inlet. Secure the support bracket to the Super-Scoop using the supplied push-in retainers. Push in the center of the retainer to fasten the lower bracket to the Super-Scoop.

**20.** Remove the Banks Ram-Air Housing (reference Banks Ram-Air installation manual for removal). Place Template 2 (page 8) over the bottom edge of the housing on the side facing the passenger side tire. Center the template and center punch the marked holes on the template. See **Figure 20**.

**21.** Drill a pilot hole over the marked location with a 1/8" drill bit. Finish drilling with a 3/8" drill bit.

**22.** Clean the holes and install the supplied Clip-On-Nuts over the holes. Install the Clip-On-Nuts so that the nut is on the inside of the Ram-Air housing. See **Figure 21**.

**23.** Re-install the Ram-Air Housing following Banks Ram-Air installation manual.

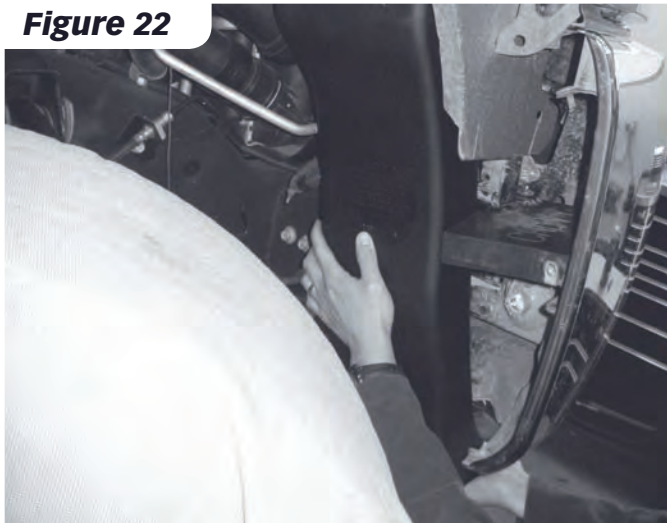
**24.** Install the Banks Super-Scoop from beneath the front bumper and place the Super-Scoop's opening over the bottom of the Banks Ram-Air housing down spout. See **Figure 22**. Place the upper bracket slots over the threaded studs on the middle bracket. Locate the supplied washer and nylock nuts and fasten the upper bracket to the lower bracket till snug.

**25.** Install the supplied bolts and washers through the Super-Scoop holes attaching to the Clip-On-Nuts on the Ram-Air Housing, see **Figure 23**. Hand tighten the bolts.

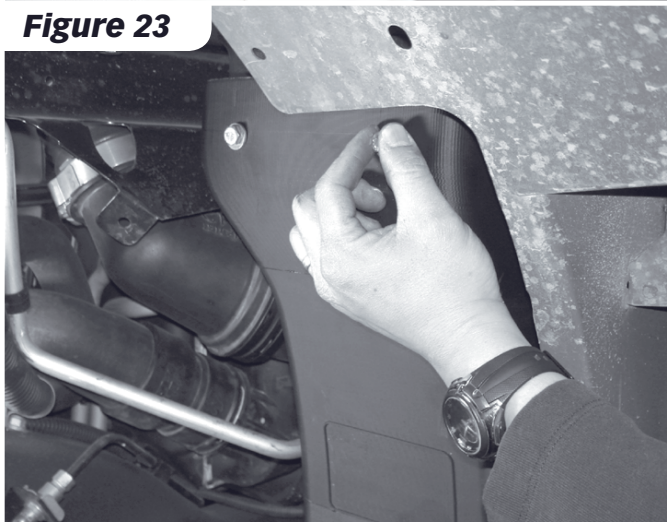
***NOTICE***: Clip-On-Nuts are self locking and will not allow the bolts to spin freely.

**26.** For MY07-10 2500, go to the inlet of the Super-Scoop and align the inlet to fit the contour of the bumper. See **Figure 24** and **Figure 25**.

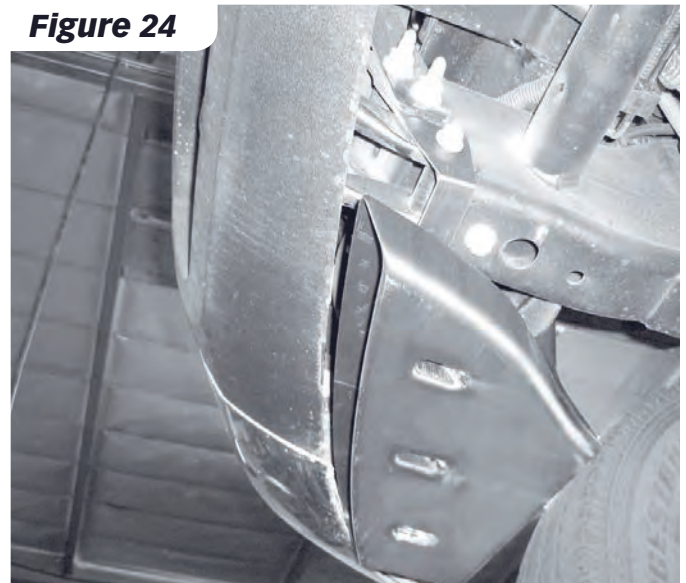
**Figure 22**



**Figure 23**



**Figure 24**



**Figure 25**



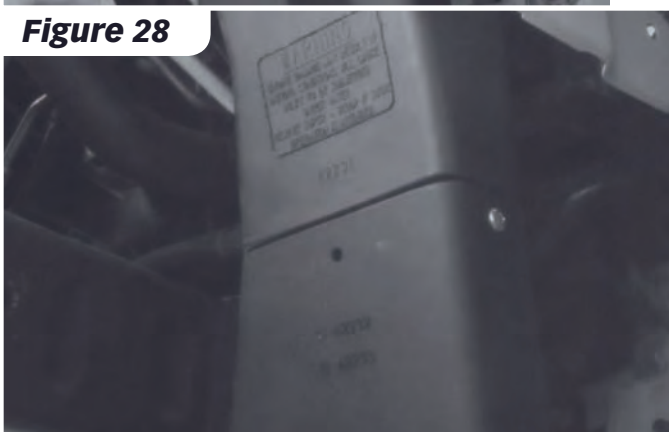
**Figure 26**



**Figure 27**



**Figure 28**



**Figure 29**



**Figure 30**



**Figure 31**



**Figure 32**



For 1500 and MY11-13, position the bottom of the inlet so it aligns to the bottom edge of valance. See **Figure 26**.

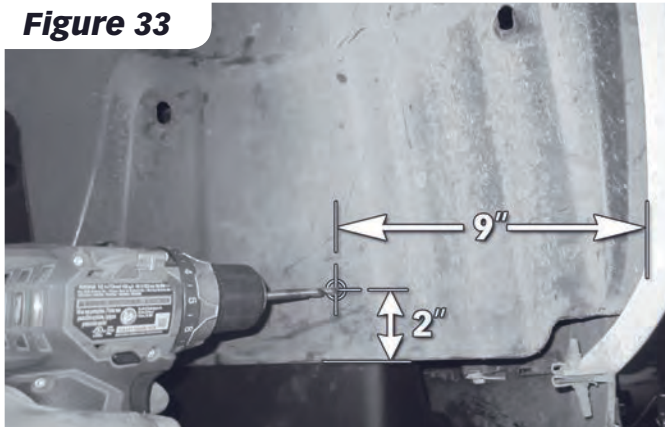
**27.** Tighten the nylock nuts that fasten the Upper Bracket to the Lower Bracket. Adjust the middle and lower bracket bolts if necessary to achieve the best fitment of the Super-Scoop. Do not reuse nylock nuts if the nylon insert is worn and is no longer self-locking.

**28.** Go back to the fender well; push the middle of Super-Scoop forward away from the wheel. Run a  $\frac{1}{4}$ " drill bit through the hole on the upper portion of the lower Super-Scoop. See **Figure 27**. Use the  $\frac{1}{4}$ " plastic retainer to secure upper and lower halves of the Super-Scoop. See **Figure 28**.

**29.** Tighten two bolts holding the Super-Scoop to Ram-Air housing. Do not reuse the clip-on-nuts if the nut is worn and is no longer self-locking.

**30.** For 1500 and MY2011-13 2500, trace the Super-Scoop inlet shape onto the valance using Template 3 (page 8). See **Figure 29**. Carefully cut the valance using a utility knife to reveal the Super-Scoop inlet. See **Figure 30**. Install the supplied edge trim to valance cut edge with outside edge (no-lip) exposed. Trim off excess edge trim. See **Figure 31 & Figure 32**.

**Figure 33**



**Figure 34**



**31.** Make sure that the Super-Scoop is in a position that does not interfere with the chassis frame, bumper support, wire harnesses, wheel well liner, or any other components.

**⚠WARNING:** If the Super Scoop is not positioned properly it will interfere with the wheel or wheel well liner. Make sure there is adequate clearance between the Super-Scoop and wheel at all extreme positions of the wheel. (Full steering and suspension travel).

**32.** Position the fender well liner into the wheel well. Attach the previously removed wire harness to the fender well liner. Install the fender well liner and secure it using the previously removed plastic retaining pins.

**NOTICE:** When installing the fastener to the cut Wheel liner support bracket make sure that it is fastened to the support bracket.

**34.** Take a measuring tape and place over the wheel liner as shown in **Figure 33**. Measure 2" from the bottom of wheel liner and 9" from the bumper edge. Mark that location.

**35.** Center punch the marked location and drill a pilot hole through the liner and into the Banks Super-Scoop with a 1/8" drill bit. Finish drilling with a 1/4" drill bit.

**36.** Locate a supplied push in retainer and insert into the drilled hole. Push in the center of the retainer to fasten it. See **Figure 34**.

**NOTICE:** Make sure the wheel well liner is secured to the Banks Super-Scoop.

**37.** You have now successfully installed the Banks Super-Scoop to your vehicle.