

banks

with Installation Instructions

Owner's Manual

Banks Ram-Air® Intake System

**1999-2003 Ford Power Stroke 7.3L
Turbo-Diesel F250/F350/F450 Trucks**

THIS MANUAL IS FOR USE WITH SYSTEM 42210 & 42210-D

banks

Also Available from Banks Power for '99-03 Ford 7.3L

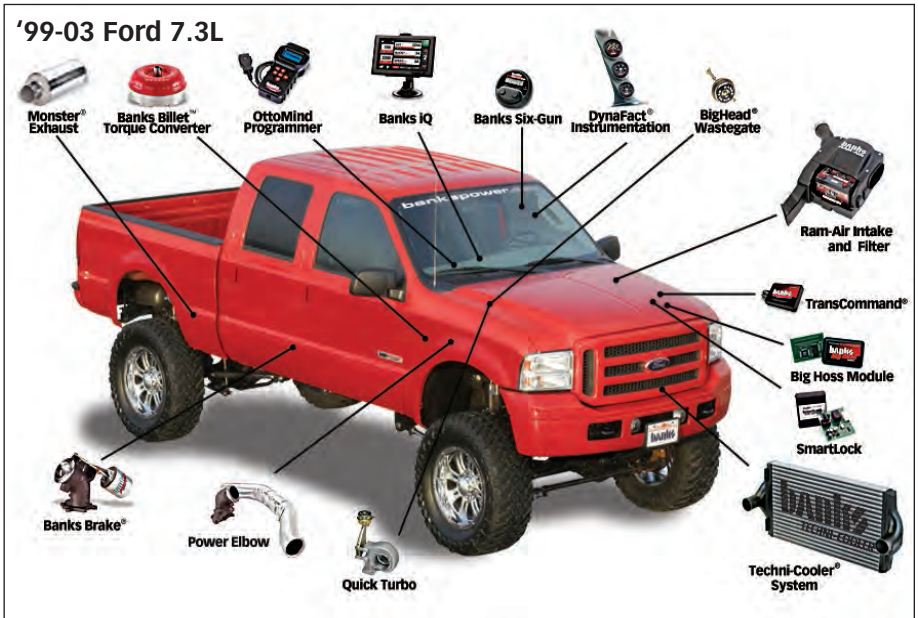

Banks Power Elbow
(P/N 48651-48652, 48661-48663)
 - Reduces stock outlet and pipe backpressure

Banks Monster® Exhaust System Sport (P/N 48789)
Single and Dual (P/N 48653-48660, 47391-47399)
 - Increases exhaust flow, cuts backpressure, lowers exhaust gas temperatures (EGTs) and increases power.

Banks Techni-Cooler® System
(P/N 25971-25973)
 - Provides increased air flow to the engine by increasing air density for more increased power, lower EGTs and improved fuel economy.

Banks Brake
(P/N 55202-55207)
 - Increases the stopping power of your truck and extends the service life of your brakes

Banks SmartLock
(P/N 55266)
 - Reduces wear on transmission
 - Locks Torque Converter and raises trans-line pressure
 - Works with Banks Exhaust Brake

Banks TransCommand
(P/N 62570)
 - Produces smooth, firm, light-throttle shifts and solid, decisive heavy-load shifts.
 - Eliminates excessive clutch slippage

Banks Billet Torque Converter
(P/N 72521)
 - Higher torque capacity over stock
 - Lockup clutch is slip-resistant so transmission fluids stay cooler and transmission life is prolonged.

Banks QuickTurbo
(P/N 24456-24457)
 - More boost through the powerband
 - Does not over-boost
 - Turbo-diesel efficiency

Banks Diesel Tuner

Six-Gun (P/N 66513-66515)

Big Hoss (P/N 66505)

- Adds power safely to your vehicle
- Engine and transmission safeguards
- Change power levels on-the-fly

Thermocouple

- Add a temperature limiting function to your Diesel Tuner

AutoMind Programmer

(P/N 66110)

- Contains Banks tunes that boost your vehicles HP, Torque and MPG.
- Displays a host of critical engine functions
- Provides "service technician" diagnostic capabilities
- Has upgradeable functionality, so it will never be out of date

Banks Git-Kit Systems

(P/N 47401, 47511-47514)

Contains:

- Monster Exhaust
- Big Hoss Module

Banks Stinger Systems

Contains:

- Ram-Air Intake Filter
- Monster Exhaust
- Big Hoss Module
- Big Head Wastegate Actuator

Banks PowerPack Systems

Contains:

- Ram-Air Intake Filter
- Monster Exhaust
- Quick-Turbo
- TransCommand
- Techni-Cooler System
- Big Head Wastegate Actuator

Banks Six-Gun Bundle

(P/N 46594-46613)

Contains:

- Ram-Air Intake Filter
- Monster Exhaust
- Six-Gun Tuner
- TransCommand
- Big Head Wastegate Actuator

Banks Big Hoss Bundle

(P/N 46623-46643)

Contains:

- Ram-Air Intake Filter
- Monster Exhaust
- Six-Gun Tuner
- TransCommand
- Big Head Wastegate Actuator
- Techni-Cooler System
- Big Hoss Module
- Power Elbow

Banks Power Combo 1

Contains:

- Big Hoss Module
- TransCommand
- Big Head Wastegate Actuator

Banks Power Combo 2

Contains:

- Six-Gun Tuner
- TransCommand
- Big Head Wastegate Actuator

Banks Power Combo 3

Contains:

- Big Hoss Module
- Monster Exhaust

Banks Power Combo 4

Contains:

- Big Hoss Module
- TransCommand
- Big Head Wastegate Actuator
- Six-Gun Tuner

General Installation Practices

Dear Customer,

If you have any questions concerning the installation of your Banks Ram-Air System, please call our Technical Service Hotline. If you have any questions relating to shipping or billing, please contact our Customer Service Department.

Thank you.

1. For ease of installation of your Banks Ram-air intake system, familiarize yourself with the procedure by reading the entire manual before starting work.

2. The exploded view of the Ram-Air assembly (pages 6-7) provides only general guidance. Refer to each step and section diagram in this manual for proper instruction.

3. Throughout this manual, the left side of the vehicle refers to the driver's side, and the right-side to the passenger's side.

4. Disconnect the ground cable from the battery before beginning work. If there are two batteries, disconnect both.

5. Route and tie wires and hoses a minimum of 6 inches away from

exhaust heat, moving parts and sharp edges. Clearance of 8 inches or more is recommended where possible.

6. During installation, keep the work area clean. If foreign debris is transferred to any Banks system component, clean it thoroughly before installing.

7. When raising the vehicle, support it on properly weight-rated safety stands, ramps or a commercial hoist. Follow the manufacturer's safety precautions. Take care to balance the vehicle to prevent it from slipping or falling. When using ramps, be sure the front wheels are centered squarely on the topsides; put the transmission in park; set the parking brake; and place blocks behind the rear wheels.

⚠ CAUTION: Do not use floor jacks to support the vehicle while working under it. Do not raise the vehicle onto concrete blocks, masonry or any other item not intended specifically for this use.

NOTICE: The Banks Oiled Ram-Air Filter comes pre-oiled and no oiling is necessary for initial installation. Service the filter as specified in the Ram-Air Filter Cleaning Instructions Section of this manual.

Tools Required:

- 3/8" drive ratchets with metric and standard sockets
- Standard and Phillips head screwdrivers
- Clean shop towels or rags
- 5/16 nut driver

Table of Contents

Section 1 **4**
General Assembly

Section 2 **6**
Ram-Air Installation

Section 3
Oiled Air Filter Cleaning Instructions . . **14**
Dry Air Filter Cleaning Instructions . . . **15**

Section 1

GENERAL ASSEMBLY

Figure 1

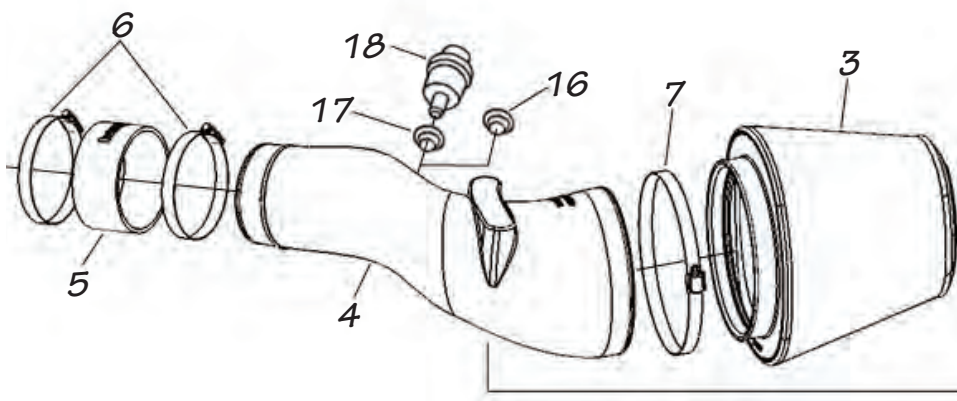

Item	Description	P/N	Qty
1	Housing, Ram-Air Filter	42211	1
2	Cover, Ram-Air Housing	42212	1
3	Air Filter Element, Ram-Air System	42188/ 42188-D	1
4	Intake Tube, Ram-Air System	42213	1
5	Hose	94303	1
6	Hose Clamp, #64	92864	2
7	Hose Clamp, #104	92904	1
8	Edge Grip seal	93140	1
9	Retainer Plate	42210-09	1
10	Screw, #4 Truss Head, Phillips, $\frac{5}{16}$ "-18 x $\frac{3}{4}$ "	91226	4
11	Washer, M8 x 24mm	91702	4
12	Hex bolt, 8mm-1.25 x 30mm, Zinc - Grade 8.8	91790	2
13	Hex bolt, 8mm-1.25 x 50mm, Zinc - Grade 8.8	91796	1
14	Hex bolt, 8mm-1.25 x 60mm, Full Thread - Grade 8	91801	1
15	Screw, Sheet Metal #4 x $\frac{3}{8}$ " - Pan head Phillips	91836	2
16	Plug, Filter Minder	92446	1

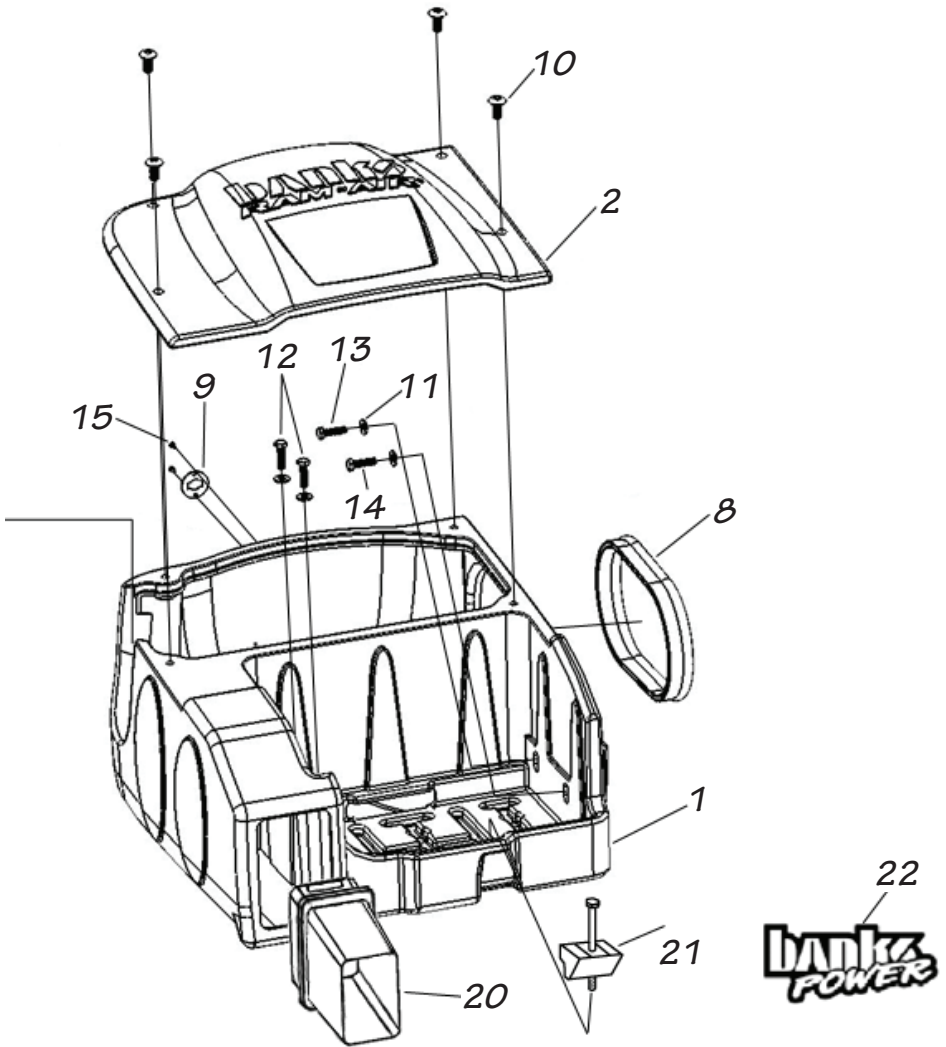

Item	Description	P/N	Qty
17	Stock Grommet, Filter Minder	*	1
18	Stock Filter Minder	*	1
19	Stock Intake Air Temperature Sensor (Not shown)	*	1
20	Stock Fresh Air Inlet Tube <i>(For Vehicles equipped with fresh air inlet tube only)</i>	*	1
21	Stock Retainer Bolt	*	1
22	Urocal, Banks Power	96009	2

* These are stock components that will be reused with the Banks Ram-Air System.

Section 2

RAM-AIR INSTALLATION

Use the Bill of Materials Chart and the General Assembly Drawing to reference component nomenclature and location. Use caution when working in the engine compartment. Make sure the engine has been OFF for several hours and cool.

You are about to install the Banks Ram-Air Intake System. Read and follow all steps before working on the vehicle. Some components from the stock air intake system will remain in service. Take care when removing stock air intake components to not damage them.

- 1.** Disconnect both battery terminals (if there is more than one battery, disconnect both).
- 2.** Remove the battery cover by releasing the tabs and pulling the cover up. See **Figure 2**.
- 3.** Unfasten and remove the battery retainer bolt located to the front of

Figure 2



the vehicle. See **Figure 3**. Retain for re-use.

- 4.** Remove the Battery from the vehicle and set aside.
- 5.** Locate the Intake Air Temperature (IAT) sensor, see **Figure 4**. Remove the sensor by gently twisting and pulling out.
- 6.** Remove the Air Filter Minder by gently twisting and pulling out of the rubber grommet. See **Figure 5**.
- 7.** Loosen the hose clamp on the air inlet and unlock the filter cover. Remove the hose clamp, intake tube and filter cover assembly from the vehicle. See **Figure 5**.
- 8.** Loosen and remove the Four (4) bolts that hold the Factory Battery tray and Air Filter box assembly in place.
- 9.** Disconnect the front fresh air inlet tube from the factory battery tray and air filter box assembly. See **Figure 6**.

Figure 3

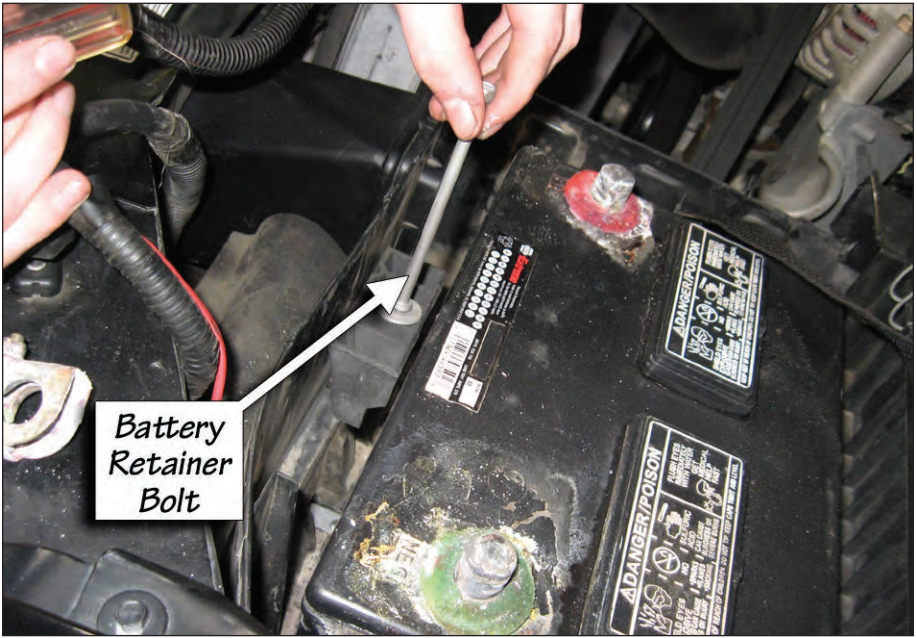

Figure 4 IAT Sensor location behind Air box Assembly

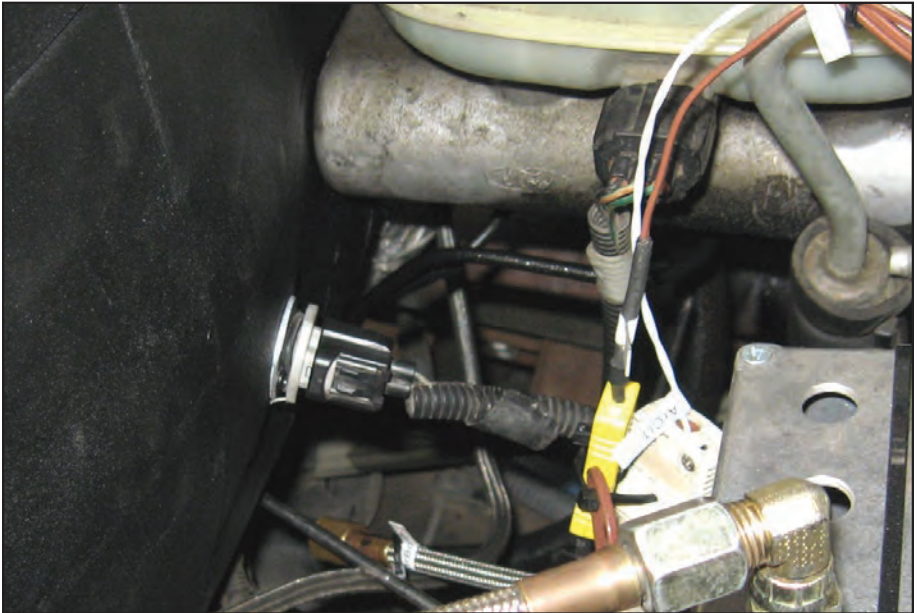

Figure 5

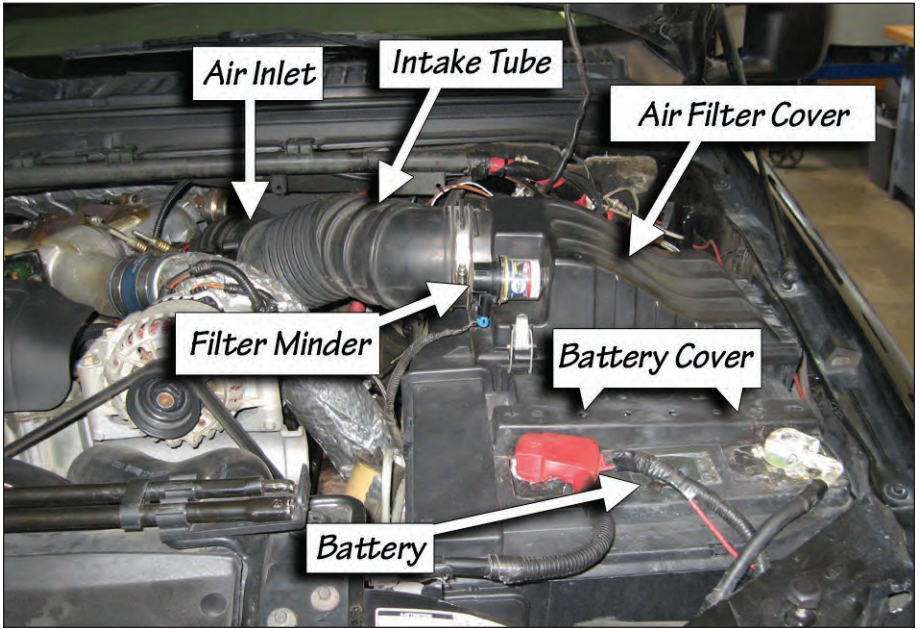
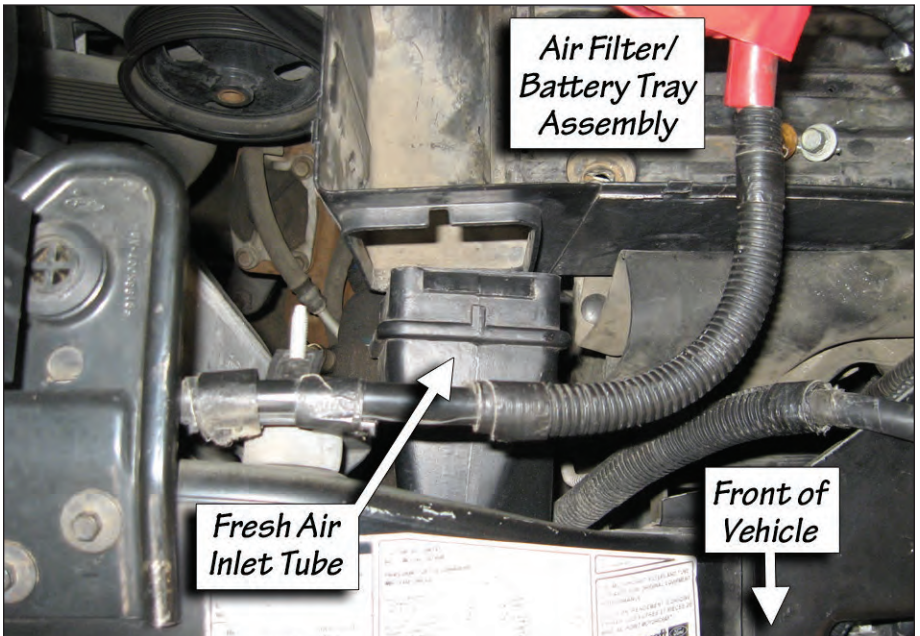

Figure 6 Vehicles equipped with Fresh Air Inlet tube only



10. Remove the factory battery tray and air filter box assembly from the vehicle.

11. From the air filter box assembly remove the factory Air Filter Minder rubber grommet.

12. Locate the Banks Intake tube and install the factory Air Filter Minder rubber grommet. See **Figure 7**.

NOTE: For Vehicles without a factory Filter Minder, insert Banks Filter Minder Plug into hole on the Banks Intake Tube if your vehicle does not come equipped with a Filter Minder.

13. Locate the Banks Air Filter Housing assembly. Install the supplied Edge Grip seal around the side opening facing the left side of the vehicle.

14. Install the supplied retainer plate and screws to the back of the Housing assembly. Insert the IAT sensor into the Air Filter Housing assembly.

15. Install the Banks Air Filter Housing assembly into place. Make

sure to align the side air inlet opening to the vehicle frame opening. Connect IAT sensor connector if previously disconnected.

NOTE: Route all wiring so that it is not obstructed by the Air Filter assembly.

16. Locate the supplied bolts and secure Banks Air Filter Housing assembly into place. See **Figure 8**. The two short bolts will go over the holes on the bottom of the Housing assembly. The longer bolt will go over the front side hole of the housing.

17. For Vehicles equipped with front fresh air inlet tube, connect the fresh air inlet tube to the air filter housing assembly. See **Figure 8**.

NOTE: Earlier production models may not be equipped with fresh air inlet tube.

18. Locate the Hose and Hose Clamps. Install the Hose onto the outlet of the Intake tube and secure in place with the Hose Clamps. See **Figure 7**.

Figure 7

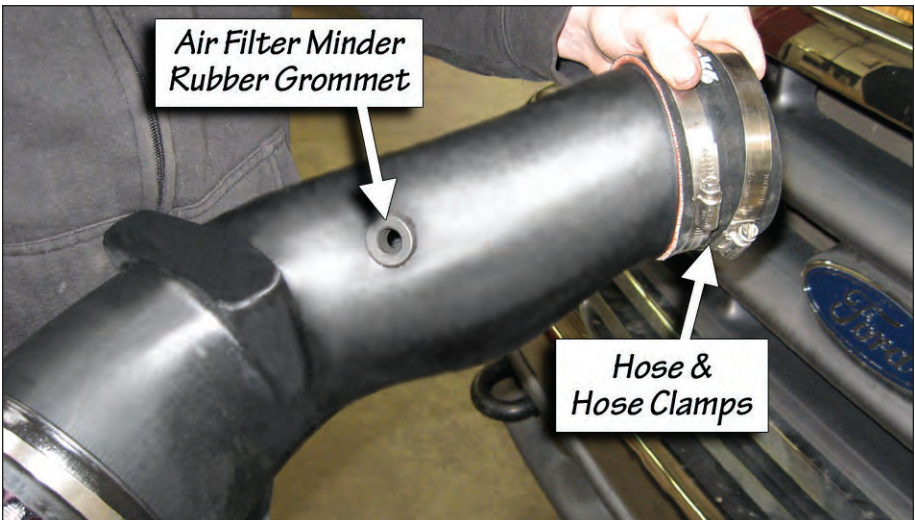

Figure 8

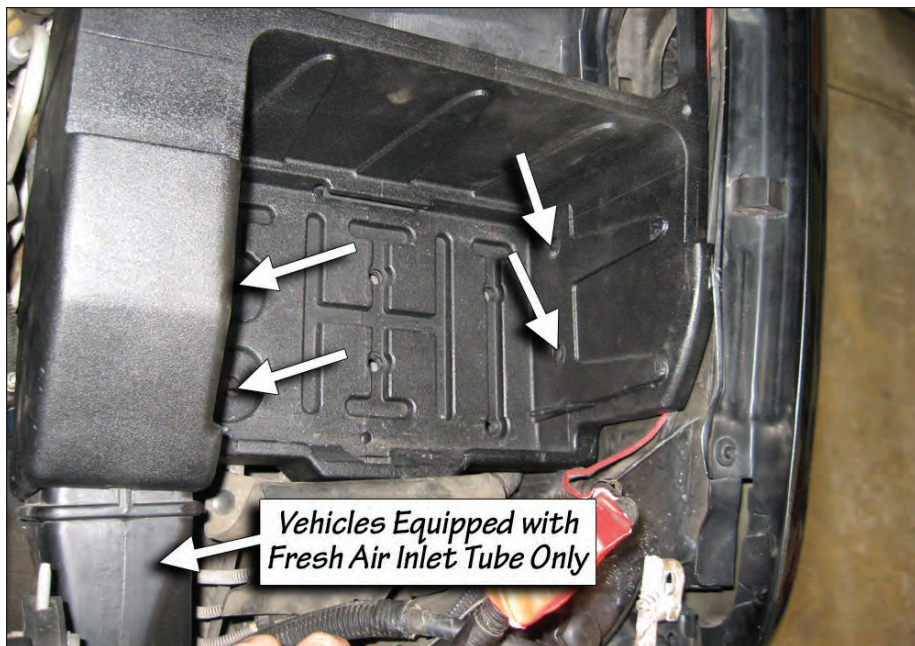

Figure 9

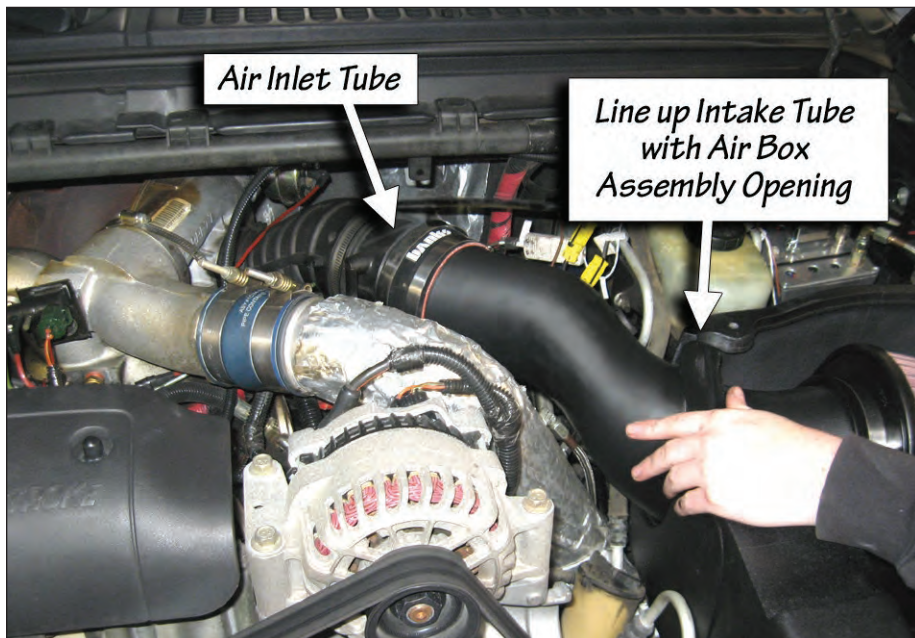
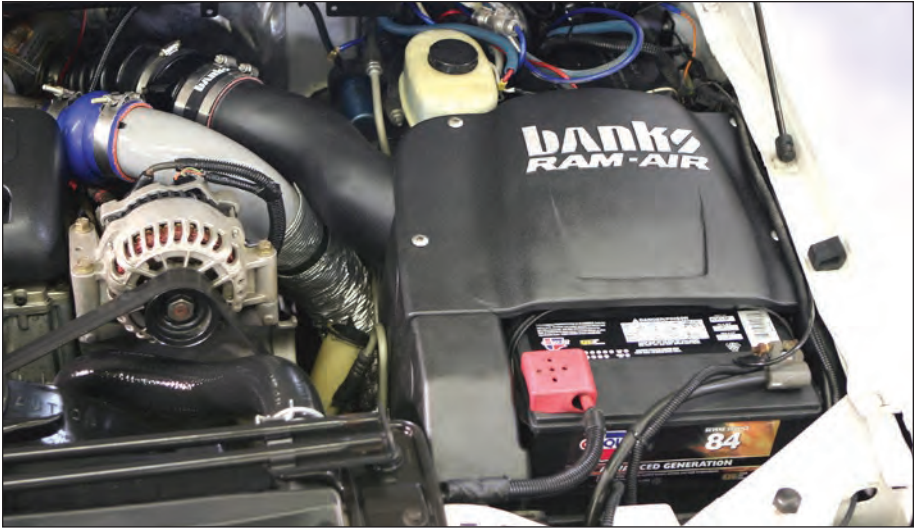

Figure 10



19. Locate the Banks Air Filter and Filter Hose clamp. Place the Air Filter hose clamp on the Banks Air filter. Do not tighten the clamp.

WARNING: Filter may come loose at connection point due to oil residue. Clean the air filter connection points with a non-oil based solvent such as Acetone, Mineral Spirits, Denatured Alcohol, or Lacquer Thinner. Read and follow the manufactures operation instruction for non-oil based solvent cleaner. Be careful not to apply cleaner to cotton filter media or damage to media may result.

20. Attach the Banks Air Filter to the Banks Intake Tube. Hand tighten the Air Filter clamp.

21. Insert the Banks Intake Tube to the air inlet tube making sure the Hose and Hose Clamps slide into place.

22. Drop the Banks Intake Tube with Air Filter into the air filter housing and align the tubing with the filter housing. See **Figure 9**.

23. Hand tighten the hose clamps at the air inlet tube and the air filter.

24. Insert the Air Filter Minder into the Intake tube.

NOTE: Route the Air Filter Minder and wiring under the intake tube to properly install in place. If necessary disconnect the Air Filter Minder from the wiring connector.

25. Place the battery into place making sure that it sits properly into the Banks Air Filter Housing assembly.

26. Install the battery retainer bolt into place and secure the battery.

27. Reconnect all battery connections.

28. Locate the Air Filter Housing cover and place over the filter. Secure with the supplied screws. You have successfully completed the installation of the Banks Ram-air Intake system. Make sure to go over all hose clamps for tightness and connectors for a secure fit. See **Figure 10**.

-END, SECTION 2-

Section 3

AIR FILTER CLEANING INSTRUCTIONS

OILED AIR FILTER ONLY

NOTICE: The Banks Ram-Air Oiled Air Filter comes pre-oiled and no oiling is necessary for initial installation. Use Banks Ram-Air Filter Cleaning System (part#90094), available from Gale Banks Engineering to service the Air Filter. Follow the instructions included with the cleaning system to clean and re-oil your Bank Ram-Air Oiled Air Filter.

1. PRE-CLEANING

Tap the element to dislodge any large embedded dirt, then gently brush with a soft bristle brush. *NOTE: If complete cleaning is not practical at this time, recoil the element and reinstall in your vehicle.*

2. SPRAY-ON CLEANING

Spray air-filter cleaner liberally onto the entire element and let soak for 10 minutes.

3. PAN CLEANING

Large air-filter elements can be rolled or soaked in a shallow pan of air-filter cleaner. Remove immediately and let soak for approximately 10 minutes.

NOTICE: NEVER use gasoline, steam, caustic solutions, strong detergents, high-pressure nozzles, or cleaning solvents to clean the filter element. All of these can cause harm to the filter media as well as SHRINK and HARDEN the rubber end caps.

4. RINSING

Rinse off the element with low-pressure water. Tap water is okay. Always flush from the clean side to dirty side. This removes the dirt

and does not drive it into the filter.

5. DRYING

Always dry naturally. After rinsing, shake off all excess water and let the element dry naturally.

6. AEROSOL OILING

After cleaning air filter always reoil before using. Spray air filter oil down into each pleat with one pass per pleat. Wait 10 minutes and re-oil any white spots still showing.

7. OILING HINTS

Never use a Banks Ram-Air filter without oil (the filter will not stop the dirt without the oil). Use only air filter oil. Air-filter oil is a compound of mineral and animal oil blended with special polymers to form a very efficient tack barrier. Red dye is added to show just where you have applied the oil. Eventually the red color will fade but the oil will remain and filter the air. NEVER USE Automatic Transmission Fluid. NEVER USE Motor Oil. NEVER USE Diesel Fuel. NEVER USE WD40, LPS, or other light-weight oils.

8. REINSTALL

Reinstall your Banks Ram-Air filter element with proper care. Make sure the element seats properly in the filter case. Install the cover making sure it's in the right position. Tighten all the nuts, bolts, screws or clips to factory specifications.

9. DO NOT DISCARD

Affix the "Do Not Discard" sticker to the filter case (included with every Banks replacement element). Make sure you put the sticker in a highly visible place to alert your mechanic not to discard.

10. PERFORMANCE HINTS

Service every 50-100,000 miles on

street-driven applications. Service more often in offroad or heavy-dust conditions. If an air-filter restriction gauge is installed, then change the element when the air-filter restriction reaches 18"–H.O.

⚠ CAUTION: **Extremely fine dust from agriculture or offroad use will pull the oil from the element. Frequent reoiling of the element's clean side might be required. Completely service when practicable. For extra protection use an air-filter sealing grease on rubber ends of the element. Service only with air-filter cleaner and air-filter oil.**

DRY FILTER CLEANING

Clean every 50-100,000 miles on street-driven applications. Clean more often in offroad or heavy-dust conditions. If an air-filter restriction gauge is installed, then change the element when the air-filter restriction reaches 18"–H.O.

1. PRE-CLEANING

Carefully tap the air filter element to dislodge any large embedded dirt or debris.

2. CLEANING

Spray an appropriate DRY AIR-FILTER CLEANER SOLUTION liberally onto both sides of the entire filter element with the majority applied to the dirty side. Soak for 10 minutes. Do not allow the DRY AIR-FILTER CLEANER SOLUTION to dry on the air filter.

NOTICE: **NEVER use gasoline, steam, caustic solutions, strong detergents, high-pressure nozzles, or cleaning solvents to clean the filter element.** All of these can cause harm to the filter media as well as SHRINK and HARDEN the rubber end caps.

3. RINSING

Rinse the filter element with cool or warm (not hot) water from the clean side out in order to flush the dirt out of the filter. It may be necessary to use your fingers on the hose to apply light water pressure. Repeat steps 2 and 3, until the water flowing through the media is completely clear of any dirt and debris.

4. DRYING

After rinsing, gently shake off excessive water and allow to dry naturally. Re-install the filter onto the intake system, airbox or custom assembly once it is dry or just slightly damp. Follow all original installation instructions.

5. REINSTALL

Reinstall your Banks Ram-Air filter element with proper care. Make sure the element seats properly in the filter case. Install the cover making sure it's in the right position. Tighten all the nuts, bolts, screws or clips to factory specifications.

6. DO NOT DISCARD

Affix the "Do Not Discard" sticker to the filter case (included with every Banks replacement element). Make sure you put the sticker in a highly visible place to alert your mechanic not to discard.

7. PERFORMANCE HINTS

Service every 50-100,000 miles on street-driven applications. Service more often in offroad or heavy-dust conditions. If an air-filter restriction gauge is installed, then change the element when the air-filter restriction reaches 18"–H.O.

-END, SECTION 3-