

**banks**

with Installation Instructions  
**Owner's Manual**

**Banks Ram-Air<sup>®</sup>  
Intake System**

**2007-2011 Jeep 3.8L**

THIS MANUAL IS FOR USE WITH KIT 41832

**banks**

# General Installation Practices

Dear Customer,

If you have any questions concerning the installation of your Banks Ram-Air System, please call our Technical Service Hotline. If you have any questions relating to shipping or billing, please contact our Customer Service Department.

Thank you.

1. For ease of installation of your Banks Ram-air intake system, familiarize yourself with the procedure by reading the entire manual before starting work. This manual contains 16 pages of copy, illustrations and parts listing. If any pages are missing from this manual please call Gale Banks Engineering immediately for a replacement.

2. The exploded view of the Ram-Air assembly (pages 4-5) provides only general guidance. Refer to each step and section diagram in this manual for proper instruction.

3. Throughout this manual, the left side of the vehicle refers to the driver's side, and the right-side to the passenger's side.

4. Disconnect the ground cable from the battery before beginning work. If there are two batteries, disconnect both.

5. Route and tie wires and hoses a minimum of 6 inches away from exhaust heat, moving parts and sharp edges. Clearance of 8 inches or more is recommended where possible.

6. During installation, keep the work area clean. If foreign debris is transferred to any Banks system component, clean it thoroughly before installing.

7. When raising the vehicle, support it on properly weight-rated safety stands, ramps or a commercial hoist. Follow the manufacturer's safety precautions. Take care to balance the vehicle to prevent it from slipping or falling. When using ramps, be sure the front wheels are centered squarely on the topsides; put the transmission in park; set the parking brake; and place blocks behind the rear wheels.

**Caution! Do not use floor jacks to support the vehicle while working under it. Do not raise the vehicle onto concrete blocks, masonry or any other item not intended specifically for this use.**

## Notification

**The Banks Ram-Air Filter comes pre-oiled and no oiling is necessary for initial installation. Service the filter as specified in the Filter Maintenance Section of this manual.**

**Tools Required:**

- 10mm socket wrench
- Standard head screwdriver
- Standard pliers
- 5/16 in nut driver
- Clean shop towels or rags

**Table of Contents**

<b>Section 1</b> .....	<b>4</b>
General Assembly	
<b>Section 2</b> .....	<b>6</b>
Ram-Air Installation	
<b>Section 3</b> .....	<b>10</b>
Filter Maintenance	

# Section 1

GENERAL ASSEMBLY

Figure 1

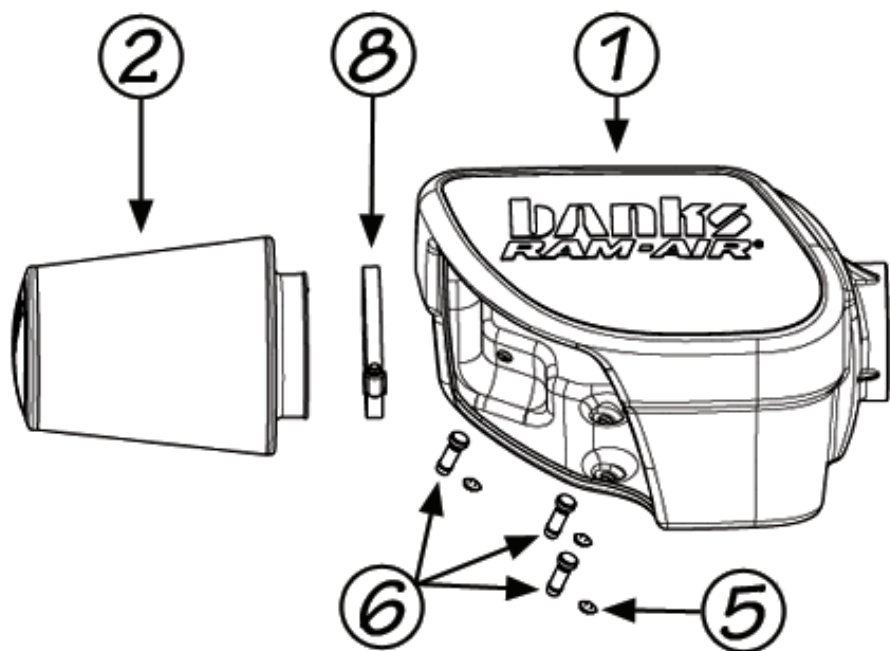

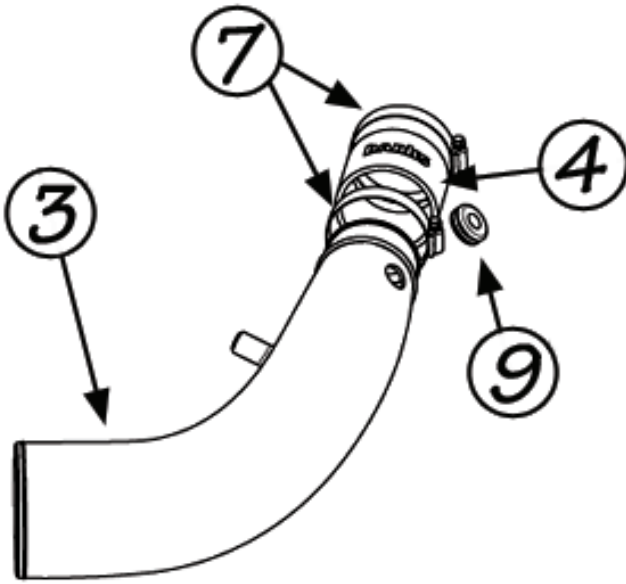

### Bill of Materials

P/N	Item	Description	QTY
41833	1	Housing, Ram-Air Filter	1
41835	2	Air Filter Element, Ram-Air System	1
41836	3	Intake Tube, Ram-Air	1
94305	4	Hose, Throttle Body	1
91701	5	E-Clip, 3/8"	3
92152	6	Mounting Peg, A/F Housing	3
92853	7	Hose Clamp, #52 W/Liner	2
92872	8	Hose Clamp, #72 W/Liner	1
93652	9	Grommet, Temp Sensor	1

## Section 2

### RAM-AIR INSTALLATION

Use the Bill of Materials Chart and the General Assembly Drawing to reference component nomenclature and location. Use caution when working in the engine compartment. Make sure the engine has been OFF for several hours and cool.

You are about to install the Banks Ram-Air Intake System. Read and follow all steps before working on the vehicle. Some components from the stock air intake system will remain in service. Take care when removing stock air intake components to not damage them.

**1.** Disconnect and remove the Air Intake Temperature (AIT) Sensor located on the intake tube by moving the red tab back and pulling the connector. Set connector aside and retain sensor for re-use. See **Figure 2**.

*Note: Take care when handling the sensor.*

**2.** Disconnect the CCV hose from the air intake tube by moving spring clamp away from joint. Retain for re-use.

**3.** Loosen both air intake hose clamps and remove the air intake tube from the engine compartment. See **Figure 3**.

**4.** Un-clip the four tabs holding the air filter housing cover. Remove the cover and the air filter from the engine compartment and set aside.

**5.** Remove the air filter housing (bottom) by lifting up from the passenger side of the engine compartment and set aside. See **Figure 4**.

**6.** Install the 3 three (supplied) Mounting Pegs onto the Banks air filter housing so that they extend out of the housing and then attach the E-Clips onto the three Mounting Pegs from the outside of the housing. See **figure 5**.

**Figure 2- Removal of AIT sensor**

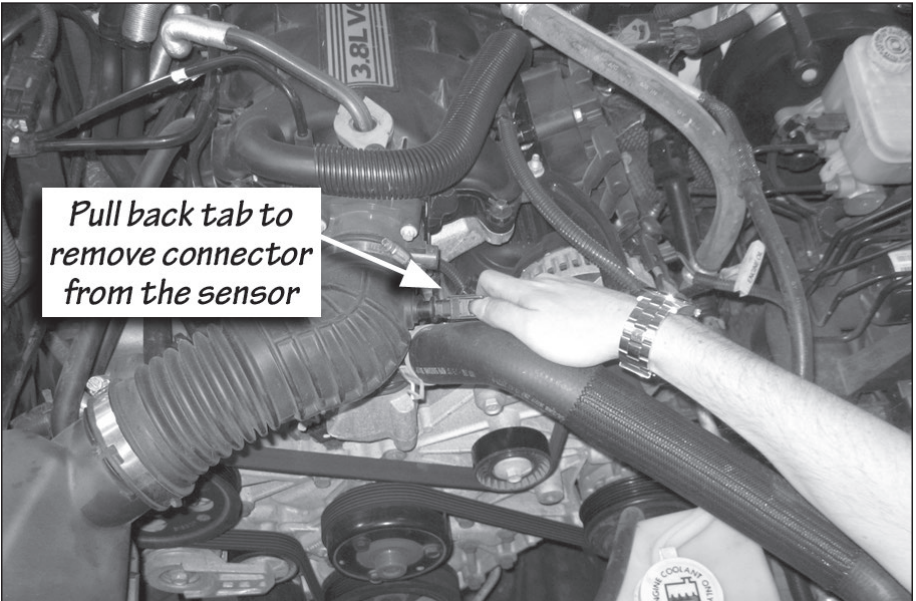

**Figure 3- Loosening hose clamps for intake tube removal**

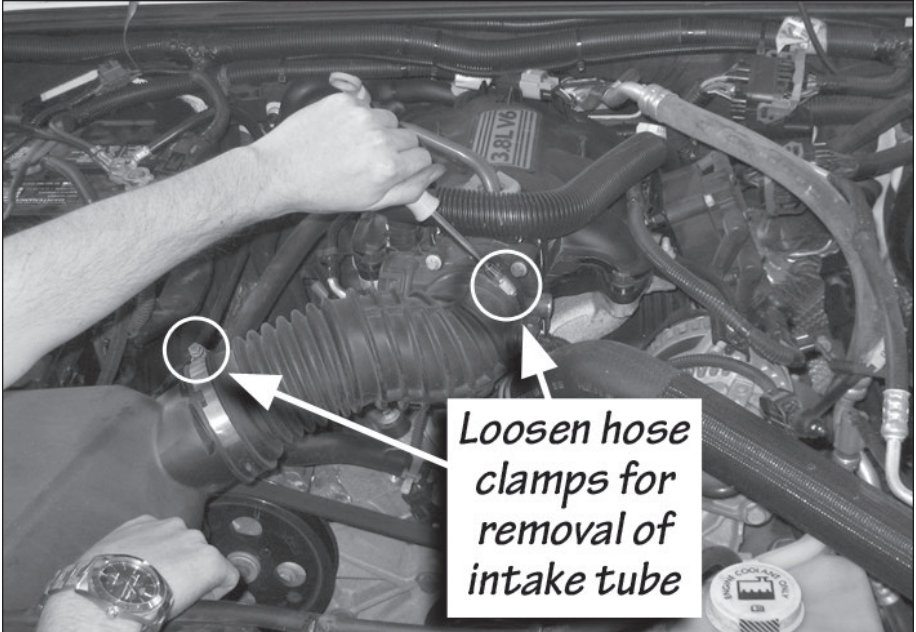

**Figure 4- Removal of filter housing bottom**

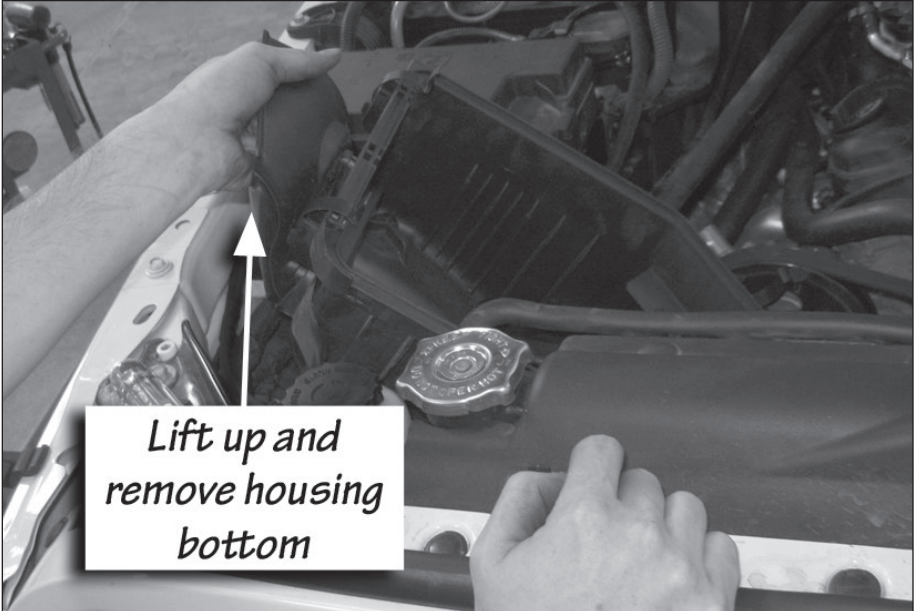

**Figure 5- Attaching mounting pegs to the housing bottom**

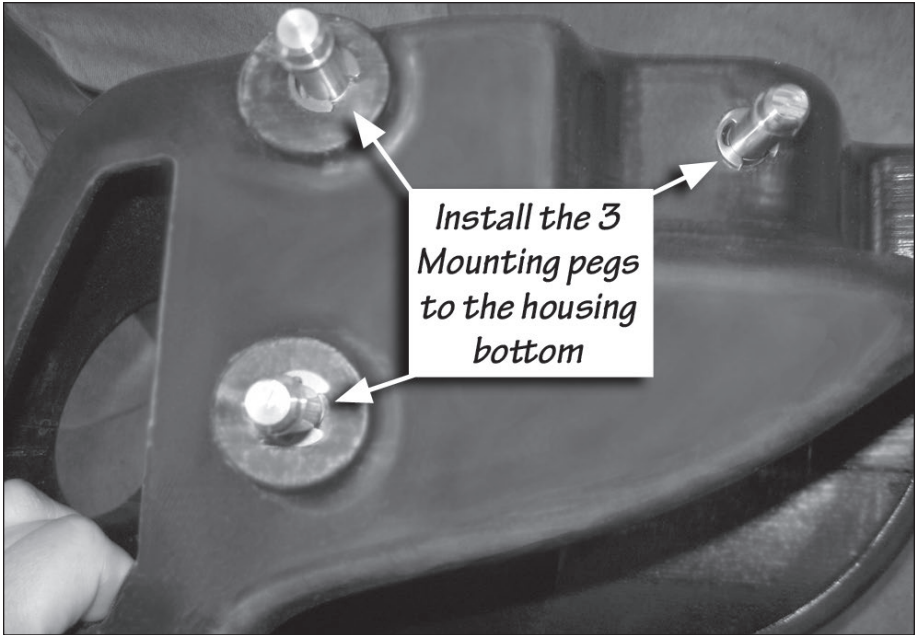

**7.** Locate the supplied filter hose clamp and install onto the Banks filter.

**8.** Locate the supplied rubber AIT grommet from your Banks kit and install onto the air intake tube.

**9.** Insert the Banks intake tube onto the Banks Ram-Air Housing; be sure to insert the end of the intake tube that has an arrow on it.

**10.** Insert the Banks air filter into the end of the Banks intake tube that is inside of the Banks Ram-Air Housing. For proper fit be sure that the arrows on the Banks air filter and intake tube line up. Tighten Banks filter hose clamp. See **Figure 6**.

**11.** Install the hose and two hose clamps onto the intake tube where it will attach to the throttle body.

**12.** Insert the Banks intake tube into the throttle body opening first. Then, Insert the three Banks air filter housing mounting pegs onto the stock grommets.

*Note: Be sure that the mounting pegs have been properly inserted onto the grommets.*

**13.** Tighten the two hose clamps that connect the Banks Ram-Air intake tube to the throttle body.

**14.** Install the AIT sensor flush into the grommet on the air intake tube. See **Figure 7**.

**15.** Re-Connect the Connector and the AIT sensor.

**16.** Re-Install the CCV vent hose connection to the Banks Ram-Air intake tube. Secure the connections by using stock spring clamps.

**17.** You have successfully completed the installation of the Banks Ram-Air Intake system. Make sure to go over all hose clamps for tightness and connectors for a sure fit. Make sure that the intake tube is not touching any engine components.

-END, SECTION 2-



**Figure 6- Connecting air filter with intake tube**

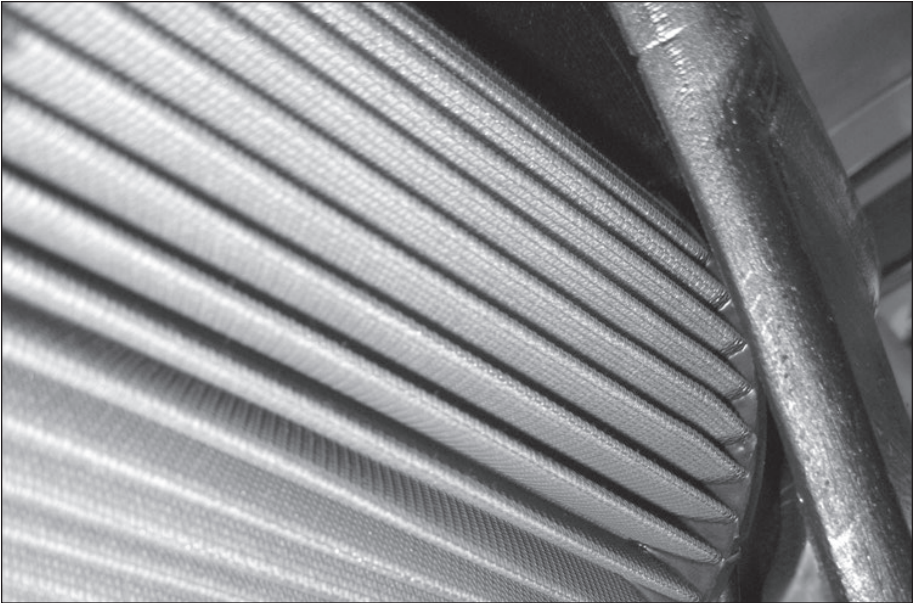

**Figure 7- Re-Installation of AIT sensor**

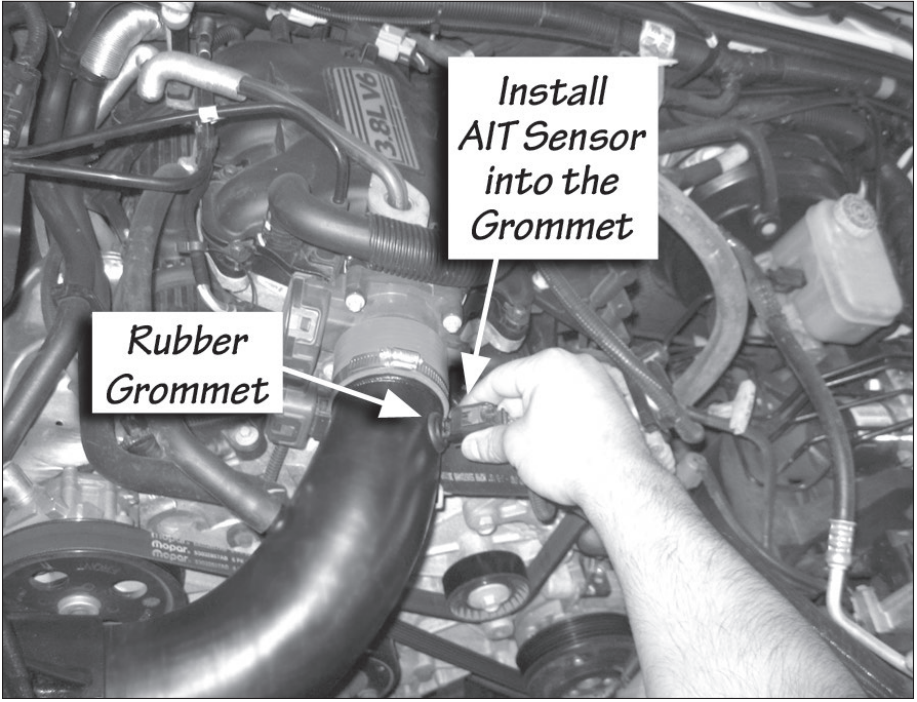

# Section 3

## AIR FILTER CLEANING INSTRUCTIONS

### OILED AIR FILTER ONLY

**NOTICE:** The Banks Ram-Air Oiled Air Filter comes pre-oiled and no oiling is necessary for initial installation. Use Banks Ram-Air Filter Cleaning System (part#90094), available from Gale Banks Engineering to service the Air Filter. Follow the instructions included with the cleaning system to clean and re-oil your Bank Ram-Air Oiled Air Filter.

#### 1. PRE-CLEANING

Tap the element to dislodge any large embedded dirt, then gently brush with a soft bristle brush. *NOTE: If complete cleaning is not practical at this time, recoil the element and reinstall in your vehicle.*

#### 2. SPRAY-ON CLEANING

Spray air-filter cleaner liberally onto the entire element and let soak for 10 minutes.

#### 3. PAN CLEANING

Large air-filter elements can be rolled or soaked in a shallow pan of air-filter cleaner. Remove immediately and let soak for approximately 10 minutes.

**NOTICE:** NEVER use gasoline, steam, caustic solutions, strong detergents, high-pressure nozzles, or cleaning solvents to clean the filter element. All of these can cause harm to the filter media as well as SHRINK and HARDEN the rubber end caps.

#### 4. RINSING

Rinse off the element with low-pressure water. Tap water is okay. Always flush from the clean side to

dirty side. This removes the dirt and does not drive it into the filter.

#### 5. DRYING

Always dry naturally. After rinsing, shake off all excess water and let the element dry naturally.

#### 6. AEROSOL OILING

After cleaning air filter always reoil before using. Spray air filter oil down into each pleat with one pass per pleat. Wait 10 minutes and re-oil any white spots still showing.

#### 7. OILING HINTS

Never use a Banks Ram-Air filter without oil (the filter will not stop the dirt without the oil). Use only air filter oil. Air-filter oil is a compound of mineral and animal oil blended with special polymers to form a very efficient tack barrier. Red dye is added to show just where you have applied the oil. Eventually the red color will fade but the oil will remain and filter the air. NEVER USE Automatic Transmission Fluid. NEVER USE Motor Oil. NEVER USE Diesel Fuel. NEVER USE WD40, LPS, or other light-weight oils.

#### 8. REINSTALL

Reinstall your Banks Ram-Air filter element with proper care. Make sure the element seats properly in the filter case. Install the cover making sure it's in the right position. Tighten all the nuts, bolts, screws or clips to factory specifications.

#### 9. DO NOT DISCARD

Affix the "Do Not Discard" sticker to the filter case (included with every Banks replacement element). Make sure you put the sticker in a highly visible place to alert your mechanic not to discard.

#### 10. PERFORMANCE HINTS

Service every 50-100,000 miles on street-driven applications. Service more often in offroad or heavy-dust conditions. If an air-filter restriction gauge is installed, then change the element when the air-filter restriction reaches 18"–H.O.

**⚠ CAUTION:** **Extremely fine dust from agriculture or offroad use will pull the oil from the element. Frequent reoiling of the element's clean side might be required. Completely service when practicable. For extra protection use an air-filter sealing grease on rubber ends of the element. Service only with air-filter cleaner and air-filter oil.**

## DRY FILTER CLEANING

Clean every 50-100,000 miles on street-driven applications. Clean more often in offroad or heavy-dust conditions. If an air-filter restriction gauge is installed, then change the element when the air-filter restriction reaches 18"–H.O.

### 1. PRE-CLEANING

Carefully tap the air filter element to dislodge any large embedded dirt or debris.

### 2. CLEANING

Spray an appropriate DRY AIR-FILTER CLEANER SOLUTION liberally onto both sides of the entire filter element with the majority applied to the dirty side. Soak for 10 minutes. Do not allow the DRY AIR-FILTER CLEANER SOLUTION to dry on the air filter.

**NOTICE:** **NEVER use gasoline, steam, caustic solutions, strong detergents, high-pressure nozzles, or cleaning solvents to clean the filter element.** All of these can cause harm to the filter media as well as SHRINK and

HARDEN the rubber end caps.

### 3. RINSING

Rinse the filter element with cool or warm (not hot) water from the clean side out in order to flush the dirt out of the filter. It may be necessary to use your fingers on the hose to apply light water pressure. Repeat steps 2 and 3, until the water flowing through the media is completely clear of any dirt and debris.

### 5. DRYING

After rinsing, gently shake off excessive water and allow to dry naturally. Re-install the filter onto the intake system, airbox or custom assembly once it is dry or just slightly damp. Follow all original installation instructions.

### 6. REINSTALL

Reinstall your Banks Ram-Air filter element with proper care. Make sure the element seats properly in the filter case. Install the cover making sure it's in the right position. Tighten all the nuts, bolts, screws or clips to factory specifications.

### 7. DO NOT DISCARD

Affix the "Do Not Discard" sticker to the filter case (included with every Banks replacement element). Make sure you put the sticker in a highly visible place to alert your mechanic not to discard.

### 8. PERFORMANCE HINTS

Service every 50-100,000 miles on street-driven applications. Service more often in offroad or heavy-dust conditions. If an air-filter restriction gauge is installed, then change the element when the air-filter restriction reaches 18"–H.O.

-END, SECTION 3-