

banks

with Installation Instructions
Owner's Manual

OEM Replacement Boost Tubes

**2013+ Dodge 6.7L Cummins (24-valve)
ISB Pickup Trucks (2500/3500)**

USE WITH SYSTEM P/N 25992, 25994, 25995, 25996

banks

General Installation Practices

Dear Customer,

If you have any questions concerning the installation of your Banks Techni-Cooler, please call our Technical Service Hotline.

Thank you.

1. Before starting work, familiarize yourself with the installation procedure by reading all of the instructions.
2. Throughout this manual, the left side of the vehicle refers to the driver's side, and the right side to the passenger's side.
3. Disconnect the negative (ground) cable from the battery (or batteries, if there are two) before beginning work.
4. Route and tie wires and hoses a minimum of 6" away from exhaust heat, moving parts and sharp edges. Clearance of 8" or more is recommended where possible.
5. When raising the vehicle, support it on properly weight-rated safety stands, ramps or a commercial hoist. Follow the manufacturer's safety precautions. Take care to balance the vehicle to prevent it from slipping or falling. When using ramps, be sure the front wheels are centered squarely on the topsides. When raising the front of the vehicle, put the transmission in park (automatic) or reverse (manual), set the parking brake, and block the rear wheels. When raising the back of the vehicle, be sure the vehicle is on

level ground and the front wheels are blocked securely.

CAUTION! Do not use floor jacks to support the vehicle while working under it. Do not raise the vehicle onto concrete blocks, masonry or any other item not intended specifically for this use.

6. During installation, keep the work area clean. Do not allow anything to be dropped into intake, exhaust, or lubrication system components while performing the installation, as foreign objects will cause immediate engine damage upon start-up.

Tools Required:

- 3/8 Drive ratchet w/ extension
- 3/8 Drive Inch and metric deep sockets
- 5/16" or 8mm Nut Driver
- Pliers
- Flat blade screwdriver
- Vehicle Lift and support stands or Floor Jack and Jack Stands (home install)

Highly recommended tools:

- Foot/ pound torque wrench
- In/ pound torque wrench

Disclaimer of Liability & Warranty

Gale Banks Engineering Inc., and its distributors, employees, and dealers (hereafter "SELLER") shall in no way be responsible for the product's proper use and service. The BUYER hereby waives all liability claims.

The BUYER acknowledges that he/ she is not relying on the SELLER's skill or judgment to select or furnish goods suitable for any particular purpose and that there are no liabilities which extended beyond the description on the face hereof and the BUYER hereby waives all remedies or liabilities, expressed or implied, arising by law or otherwise, (including without any obligations of the SELLER with respect to fitness, merchantability, and consequential damages) whether or not occasioned by the SELLER's negligence. The BUYER is responsible to fully understand the capability and limitations of his/her vehicle according to manufacturer specifications and agrees to hold the SELLER harmless from any damage resulting from the failure to adhere to such specifications.

The SELLER disclaims any warranty and expressly disclaims any liability for personal injury or damages. The BUYER acknowledges and agrees that the disclaimer of any liability for personal injury is a material term for this agreement and the BUYER agrees to indemnify the SELLER and to hold the SELLER harmless from any claim related to the item of the equipment purchased. Under no circumstances will the SELLER be liable for any damages or expenses by reason of the use or sale of any such equipment.

The BUYER is responsible to obey all applicable federal, state, and local laws, statutes, and ordinances when operating his/ her vehicle, and the BUYER agrees to hold SELLER harmless from any violation thereof.

The SELLER assumes no liability regarding the improper installation or misapplication of its products. It is the BUYER's responsibility to check for proper installation and if in doubt, contact the manufacturer. The BUYER is solely responsible for all warranty issues from the automotive manufacturer.

The use of this device signifies automatic approval of these conditions.

Section 1

GENERAL ASSEMBLY, 25992, 25995

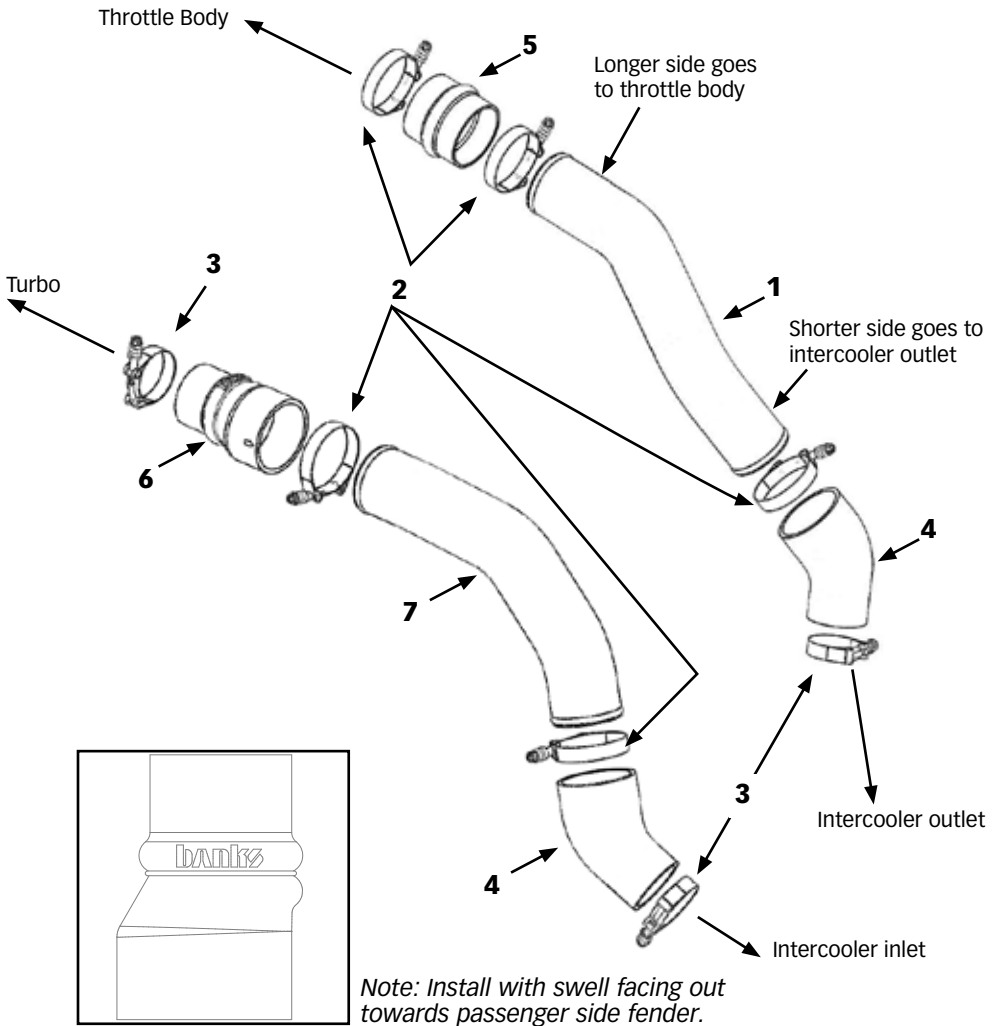

| Item # | Description | Part # | QTY |
|--------|--|------------------|-----|
| 1 | Boost Tube, Left (Driver Side) | 42464-R, 42464-N | 1 |
| 2 | T-Bolt Clamp, 3.5" Spring Loaded | 92901 | 5 |
| 3 | T-Bolt Clamp, 3.0" Spring Loaded | 92860 | 3 |
| 4 | Hose Coupler, 2.75" to 3.5", 43 Degree Elbow | 94329 | 2 |
| 5 | Hump Hose Coupler, 3.5in ID x 3.5" L, Black, Silicone, CAC | 94293 | 1 |
| 6 | Hose Coupler, 2.75" to 3.5" X 6" Long, Centerline Offset | 94328 | 1 |
| 7 | Boost Tube, Right (Passenger Side) | 42465-R, 42465-N | 1 |

Section 1

GENERAL ASSEMBLY, 25994, 25996

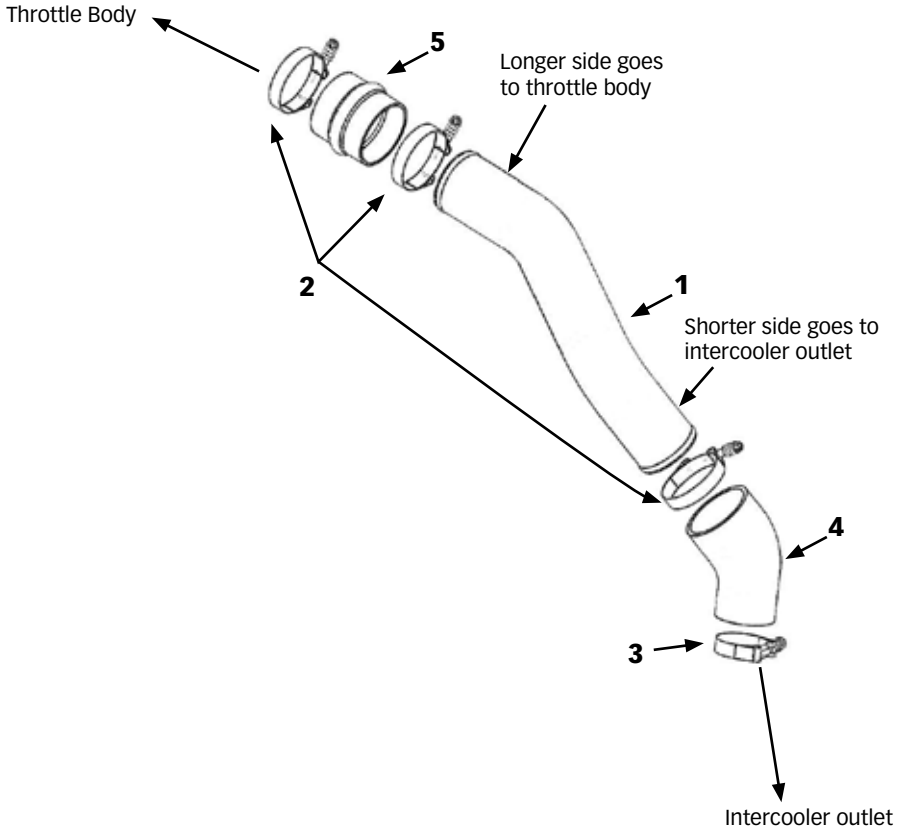

| Item # | Description | Part # | QTY |
|--------|--|------------------|-----|
| 1 | Boost Tube, Left (Driver Side) | 42464-R, 42464-N | 1 |
| 2 | T-Bolt Clamp, 3.5" Spring Loaded | 92901 | 3 |
| 3 | T-Bolt Clamp, 3.0" Spring Loaded | 92860 | 1 |
| 4 | Hose Coupler, 2.75" to 3.5", 43 Degree Elbow | 94329 | 1 |
| 5 | Hump Hose Coupler, 3.5in ID x 3.5" L, Black, Silicone, CAC | 94293 | 1 |

Section 2

REMOVE AIR BOX AND FENDER LINERS

1. Remove the bolt, using a 13mm socket, from the radiator core support that secures the factory air housing. (See **Figure 2**)

Figure 2

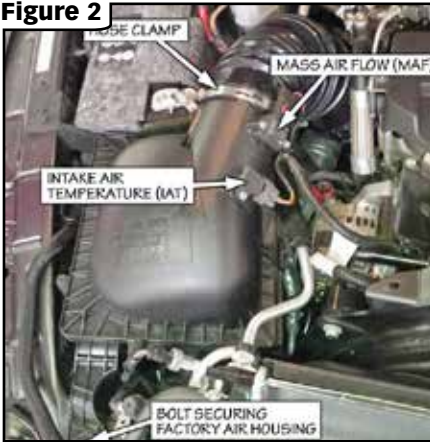

2. Loosen the hose clamp to the stock intake tube attached to the air housing.

3. Slide the red locking mechanism up on the Mass Air Flow (MAF) sensor connector. Press the tab on the connector and remove the connector. Press the tab on the Intake Air Temperature (IAT) sensor connector and remove the connector. Pull the plastic anchor holding the wiring harness to the air housing lid and move the harness out of the way.

4. Lift the air housing up and partially out of the engine compartment to gain access to the Ram Active Air® actuator connector on the actuator motor on the side near the bottom of the housing (See **Figure 3**). Be careful not to pull the housing up too far to damage the wiring harness. Once the housing is

pulled out enough to gain access to this connector depress the tab on the end of the connector and disconnect the connector from the motor. The housing can now be removed completely from the vehicle.

Figure 3

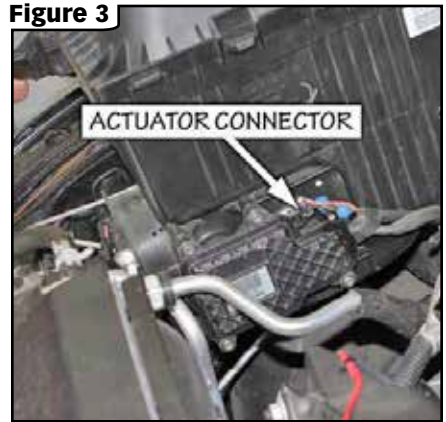

5. Locate the spring clamp retaining the PCV hose (See **Figure 4**). Using appropriate pliers loosen the clamp and slide it up over the metal tube and out of the way. With the clamp out of the way, pull the hose to disconnect from the metal tube.

Figure 4



Section 2

REMOVE AIR BOX AND FENDER LINERS, *continued*

6. Loosen the hose clamp holding the intake tube to the turbo inlet and remove the intake tube from the vehicle (See **Figure 5**).

Figure 5



Remove Driver and Passenger Side Fender Liners

- 1.** Lift and support vehicle.
- 2.** Remove both front wheels and tires.
- 3.** Remove all the 8mm hex head screws holding the fender liners in place.
- 4.** Carefully pull the fender liners out.

Section 3

INSTALL DRIVER SIDE BOOST TUBE, 42464 OR 42464-N

Install Driver Side Boost Tube

1. Use a 7/16" deep socket to loosen the two clamps holding the boost tube to the throttle body and intercooler outlet. Pull out the tube and discard the clamps.

2. Using **Figure 6a**, slip the 2 T-Bolt Clamps (6 & 7) onto the elbow hose coupler (4) and install onto the intercooler outlet. (also see **Figure 1**)

Figure 6a

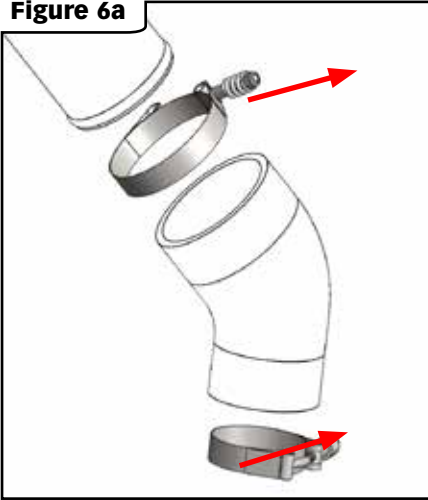

3. Using **Figure 6b**, slip the 2 T-Bolt Clamps (6) onto the straight hose coupler (5) and install appropriate end on the driver side Boost Tube. (also see **Figure 1**)

4. Install the Boost Tube into place and torque hose clamps to 5 ft.-lbs (60 in.-lbs).

Figure 6b

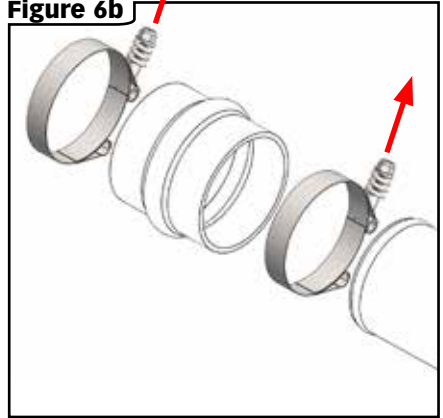

Section 4

INSTALL PASSENGER SIDE BOOST TUBE, 42465 OR 42465-N

Note: Skip to section 5 if installing kit 25994 or 25996 (Driver side tube only)

1. Use a 7/16" deep socket to loosen the two clamps holding the boost tube to the turbo discharge and intercooler inlet. Pull out the tube and discard the clamps.

2. Using **Figure 6c**, slip the 2 T-Bolt Clamps (**6 & 7**) onto the elbow hose coupler (**4**) with the correct orientation and install onto the intercooler inlet. (also see **Figure 1**)

Figure 6c

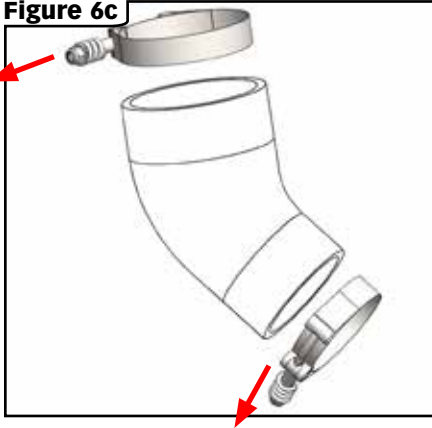

3. Using **Figure 6d**, slip the 2 T-Bolt Clamps (**6 & 7**) onto the transition hose coupler (**3**) and install the coupler onto to the appropriate end on the passenger side Boost Tube. Make sure that the swell on the coupler is pointing out away from the vehicle. (also see **Figure 1**)

4. Install the Boost Tube into place and torque clamps to 5 ft.-lbs (60 in-lbs).

Figure 6d

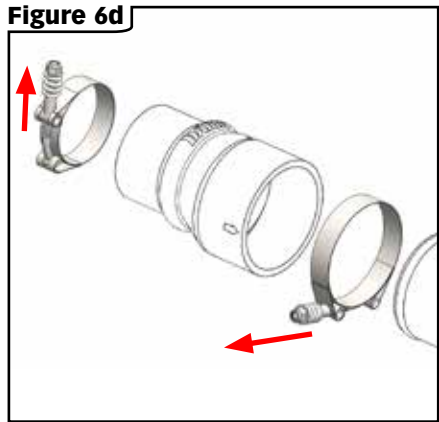

Section 5

REINSTALL AIR BOX AND FENDER LINER

1. Push the fender liners in place.
2. Reinstall the 8mm hex head screws.
3. Reinstall the wheels and tires.
4. Lower the vehicle.
9. Adjust the intake tube and slip it into the intake filter.

Reinstall the Air Box

5. Install the intake tube onto the turbo inlet.
6. Reinstall the PCV hose and clamp.
7. Drop the air box in place and reconnect the Ram Active Air® actuator connector.
8. Push the air box into place making sure that the two pins on the bottom of the air box pop into the grommets.
10. Tighten all the intake clamps.
11. Reconnect the MAF and IAT sensor connectors and secure them.
12. Tighten the front intake bolt using the 13mm socket.
13. Reconnect the negative (ground) cable to the battery (or, batteries).
14. Your system includes two Banks Power decals (8) designed to complement the Dodge Cummins Turbo Diesel emblem on your truck. Use the provided measurements to position the logos for a clean factory look (see **Figure 6**).

Figure 16

