

banks

with Installation Instructions
Owner's Manual

Banks Monster[®] Exhaust

Jeep 4.0L I-6 models:
1991-95 Wrangler (YJ)
1997-06 Wrangler (TJ)
2004-06 Wrangler Unlimited

Jeep 2.5L I-4 models:
1997-03 Wrangler (TJ)

THIS MANUAL IS FOR USE WITH SYSTEMS 51311, 51312,
51313, 51314 & 51315

BANKS

General Installation Practices

1. For ease of installation of your Banks system, familiarize yourself with the procedure by reading the entire manual before starting work.

2. The exploded view (**Figure 1**) provides only general guidance. Refer to each step and section diagram in this manual for proper instruction.

3. Throughout this manual, the left side of the vehicle refers to the driver's side, and the right side to the passenger's side.

4. Disconnect the ground cable from the battery (or batteries, if there are two) before beginning work.

5. Route and tie wires and hoses a minimum of 6" away from exhaust heat, moving parts and sharp edges. Clearance of 8" or more is recommended where possible.

6. When raising the vehicle, support it on properly weight-rated safety stands, ramps or a commercial hoist. Follow the manufacturer's safety precautions. Take care to balance the vehicle to prevent it from slipping or falling. When using ramps, be sure the front wheels are centered squarely on the topsides; put the transmission in park; set the hand brake; and place blocks behind the rear wheels.

Caution! Do not use floor jacks to support the vehicle while working under it. Do not raise the vehicle onto concrete blocks, masonry or any other item not intended specifically for this use.

7. During installation, keep the work area clean. Do not allow anything to

be dropped into intake, exhaust, or lubrication system components while performing the installation, as foreign objects will cause immediate engine damage upon start-up.

Tools Required:

- 1/4" and 3/8" drive ratchets with inch and metric sockets and 1/4" and 3/8" drive extension
- Inch and metric combination or open-end wrenches
- Standard screwdriver
- Standard and needle-nose pliers
- Clean shop towels or rags

Highly recommended tools and supplies:

- Inch-pound and foot-pound torque wrenches
- Compressed air source and hose
- Air pressure regulator
- Penetrating oil or light lubricant spray
- Reciprocating saw

Figure 1 (General Assembly)

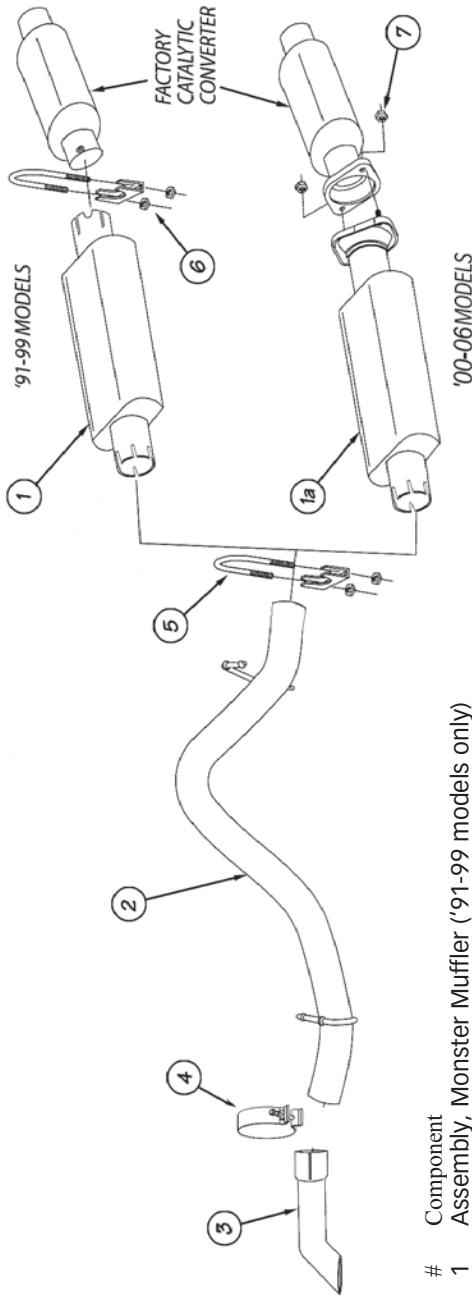

- | # | Component |
|----|---|
| 1 | Assembly, Monster Muffler ('91-99 models only) |
| 1a | Assembly, Monster Muffler ('00-06 models only) |
| 2 | Pipe, 2 1/2" Tailpipe |
| 3 | Tailpipe Turndown Tip |
| 4 | Band Clamp, 2 1/2" |
| 5 | Clamp, 2 1/2" |
| 6 | Clamp, 2 1/4" ('91-99 models only) |
| 7 | (2) Nuts, serrated 10-1.50 ('00-06 models only) |

Installation Instructions

1. Raise the vehicle on a hoist or safety stands to provide access to the exhaust system.
2. For 2000-05 models, remove the 10-mm hardware from the catalytic converter and muffler connection. For all other models, loosen and remove the clamp that connects the factory muffler to the catalytic converter. An oxyacetylene torch may be useful at the muffler and catalytic converter connection. (If applicable, be sure to remove the O₂ sensor on the catalytic converter before operating the torch.)
3. Remove the hanger pins from the rubber hangers at the rear of the tailpipe. (Spray lubricant will ease hanger removal.) Remove the muffler and tailpipe from vehicle. Cutting the tailpipe may ease the removal process.

4. Install the Banks Monster muffler onto the catalytic converter. Be sure the exhaust inlet is facing towards the catalytic converter. For 2000-05 models, loosely install the supplied 10-mm hardware onto the catalytic converter and muffler studs. For all other models, position the muffler so that it is straight and level with the vehicle. Loosely install the supplied 2 1/4" clamp onto the muffler and catalytic converter connection (see Figure 1).
5. Place the supplied 2 1/2" clamp onto the Banks Monster muffler outlet. Install the tailpipe over the rear axle housing into the outlet of the muffler. Connect the tailpipe hanger pins to the factory rubber hangers.
6. Install the supplied 2 1/2" band clamp about a 1/2" on the rear of the turndown tip (so that clamp rests on the tailpipe cutouts). Slip the 2 1/2"

Figure 2

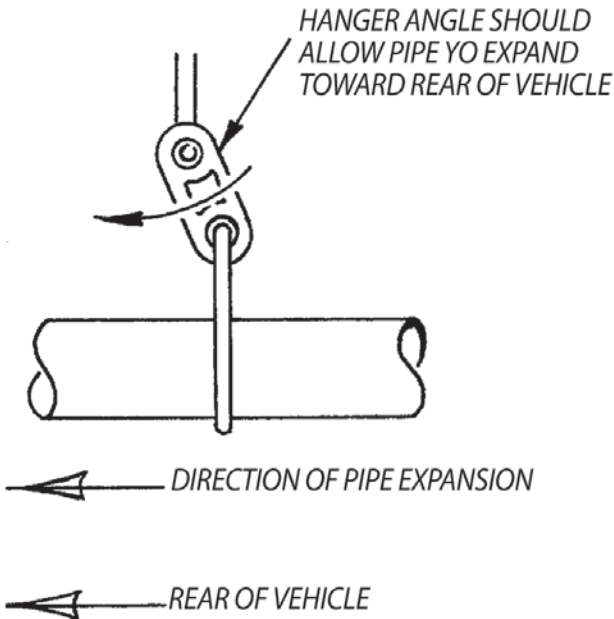

polished tailpipe turndown tip over the tailpipe. The tailpipe tip should be completely pressed onto the tailpipe.

7. Position all the exhaust components such that all the hanger pins are parallel with the frame pins and all exhaust tubing is located properly. Lightly tighten clamps to maintain position. The tailpipe tip should be position 1-2" below the bottom edge of the vehicle body. All hangers should be hanging slightly forward to allow for heat expansion of the exhaust tubing (see **Figure 2**).

8. With everything positioned properly, torque the 10-mm hardware (on **2000-05 models**) and clamps to 25-30 ft-lbs.

9. Reconnect the battery. Start the vehicle and listen for exhaust leaks. Tighten the clamps as necessary. Whenever possible, tack-welding slip connections to prevent disengagement is recommended.

Note: The vehicle exhaust may smoke upon initial start-up. This is normal, as grease used in the tube bending process burns off the pipes.

10. Your Banks Monster Exhaust system contains two (2) Banks Power decals. For a clean factory look, it is recommended that the decals are placed above the "4.0L" emblem on the passenger and driver side front fenders.

Parts List, Banks Stinger Systems

P/N	Description	Qty
51315	2004-06 Jeep Wrangler Unlimited (4.0L)	
52638	Muffler, Banks Monster	(1)
52656	Tailpipe*	(1)
52973	Tip, Polished Stainless Steel	(1)
52462	Band-Clamp, Exhaust 2 1/2"	(1)
52461	Clamp Exhaust 2 1/2"	(1)
91805	Nut, 10mm-1.5 Serrated	(2)
96392	Product Registration Card	(1)
96503	Warranty Statement	(1)
96009	Decal, Banks Power	(2)

51314	2004-06 Jeep Wrangler (4.0L)	
52638	Muffler, Banks Monster	(1)
52655	Tailpipe*	(1)
52973	Tip, Polished Stainless Steel	(1)
52462	Band-Clamp, Exhaust 2 1/2"	(1)
52461	Clamp Exhaust 2 1/2"	(1)
91805	Nut, 10mm-1.5 Serrated	(2)
96392	Product Registration Card	(1)
96503	Warranty Statement	(1)
96009	Decal, Banks Power	(2)

51313	2000-03 Jeep Wrangler (2.5-4.0L)	
52637	Muffler, Banks Monster	(1)
52655	Tailpipe	(1)
52973	Tip, Polished Stainless Steel	(1)
52462	Band-Clamp, Exhaust 2 1/2"	(1)
52461	Clamp Exhaust 2 1/2"	(1)
91805	Nut, 10mm-1.5 Serrated	(2)
96392	Product Registration Card	(1)
96503	Warranty Statement	(1)
96009	Decal, Banks Power	(2)

51312 1997-99 Jeep Wrangler (2.5-4.0L)

52636	Muffler, Banks Monster	(1)
52654	Tailpipe*	(1)
52973	Tip, Polished Stainless Steel	(1)
52461	Clamp, Exhaust 2 1/2"	(1)
52462	Band-Clamp, Exhaust 2 1/2"	(1)
52460	Clamp, Exhaust 2 1/4"	(1)
96392	Product Registration Card	(1)
96503	Warranty Statement	(1)
96009	Decal, Banks Power	(2)

51311 1991-95 Jeep Wrangler (4.0L)

52636	Muffler, Banks Monster	(1)
52653	Tailpipe	(1)
52973	Tip, Polished Stainless Steel	(1)
52461	Clamp, Exhaust 2 1/2"	(1)
52462	Band-Clamp, Exhaust 2 1/2"	(1)
52460	Clamp, Exhaust 2 1/4"	(1)
96392	Product Registration Card	(1)
96503	Warranty Statement	(1)
96009	Decal, Banks Power	(2)

* Unlimited uses Tailpipe 52656