

**banks**

with Installation Instructions  
**Owner's Manual**

# **Banks Monster<sup>®</sup> Exhaust System**

**2011 Ford Power Stroke 6.7L  
Turbo-Diesel F-250/F-350/F-450 Trucks  
Crew Cab 6.75ft & 8ft bed**

THIS MANUAL IS FOR USE WITH SYSTEM 49788

**BANKS**

# General Installation Practices

1. Before starting work, familiarize yourself with the installation procedure by reading all of the instructions.
2. The exploded view (**Figure 1**, pages 4-5) provides only general guidance. Refer to each step and section diagram in this manual for proper instruction.
3. Throughout this manual, the left side of the vehicle refers to the driver's side, and the right side to the passenger's side.
4. Disconnect the negative (ground) cable from the battery (or batteries, if there are two) before beginning work.
5. Route and tie wires and hoses a minimum of 6" away from exhaust heat, moving parts, and sharp edges. Clearance of 8" or more is recommended where possible.
6. When raising the vehicle, support it on properly weight-rated safety stands, ramps or a commercial hoist. Follow the manufacturer's safety precautions. Take care to balance the vehicle to prevent it from slipping or falling. When using ramps, be sure the front wheels are centered squarely on

the topsides. When raising the front of the vehicle, put the transmission in park (automatic) or reverse (manual), set the parking brake, and block the rear wheels. When raising the back of the vehicle, be sure the vehicle is on level ground and the front wheels are blocked securely.

**CAUTION! Do not use floor jacks to support the vehicle while working under it. Do not raise the vehicle onto concrete blocks, masonry or any other item not intended specifically for this use.**

7. During installation, keep the work area clean. Do not allow anything to be dropped into intake, exhaust, or lubrication system components while performing the installation, as foreign objects will cause immediate engine damage upon start-up.

## Tools Required:

- 1/2" and 3/8" drive ratchets with inch and metric sockets and 1/2" and 3/8" drive extension
- Inch and metric combination or open-end wrenches
- Standard screwdriver
- Clean shop towels or rags
- Pry-bar
- Reciprocating saw

## Highly recommended tools and supplies:

- Foot-pound torque wrenches
- Penetrating oil or light lubricant spray
- Oxy-acetylene torch

# Products available from Banks Power for the 2011 Ford 6.7L

2011 Ford 6.7L



## **Banks Monster Dual Exhaust (P/N 49790)**

- Increases exhaust flow, cuts backpressure, lowers exhaust gas temperatures (EGTs) and increases power.

## **Banks Ram-Air Intake System (P/N 42215)**

- Increases your airflow over stock.
- Adds power, improves fuel economy, lowers EGTs and reduces smoke.

Figure 1

# General Assembly Diagram

Item	Description	P/N	Qty.
1	Intermediate Pipe	53997	1
2	Rear Hanger Clamp, 4"	53981	1
3	Front Tailpipe	53988	1
4	Rear Tailpipe	53982	1
5	Exhaust Clamp, 4"	52470	1
6	Nut, Crimp Lock 7/16"-20	91619	3
7	Washer, SAE Flat, Zinc - 7/16"	91602	6
8	Hex Bolt, Grade 5, Zinc - 7/16"-20	91629	3
9	Gasket, Intermediate Pipe	93211	1
10	Urocal, Bank Power	96009	2

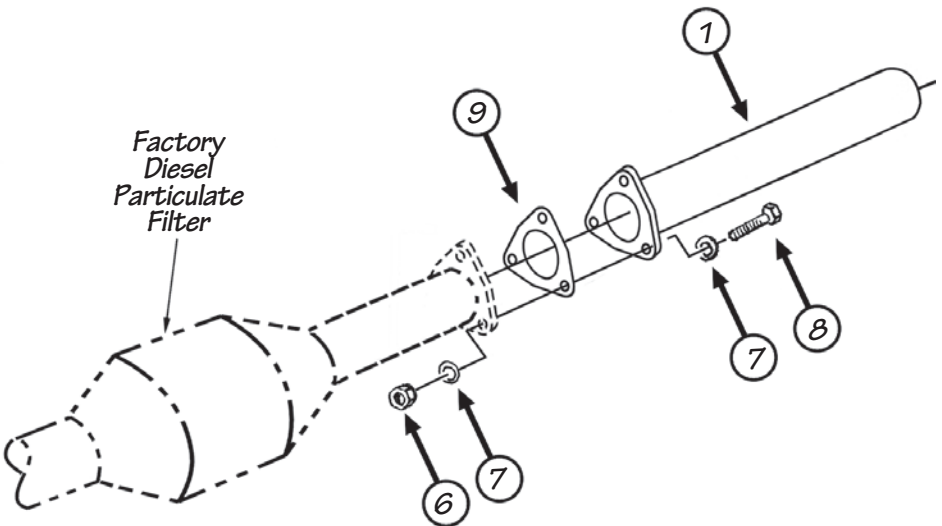

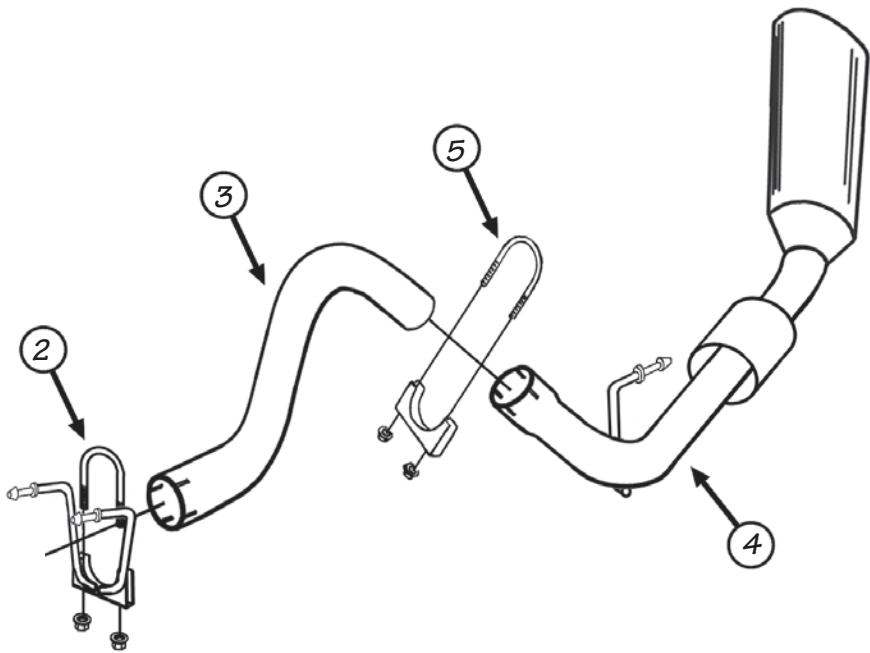

**Banks  
POWER**

10

# Monster Exhaust System Installation

**1.** As a precaution, disconnect the ground of the battery (if there is more than one battery, disconnect both).

**2.** Raise the vehicle and support it with properly weight rated safety stands, ramps or a commercial hoist. Follow the manufacturer's safety precautions. Take care to balance the vehicle to prevent it from slipping or falling. When using ramps, be sure the front wheels are centered squarely on the topsides; place the transmission in park; set the parking brake and place blocks behind the rear wheels.

**CAUTION: DO NOT WORK UNDER ANY VEHICLE SUPPORTED ONLY BY A JACK. SEVERE INJURY MAY RESULT.**

**WARNING! The following step may require the use of a torch and/or saw. Proper safety equipment should be used. Failure to use proper safety equipment may result in severe injury.**

**3.** Removal of the factory exhaust can be simplified by cutting the factory exhaust pipe behind the muffler. This will allow the tailpipe to be removed as a separate piece.

**4.** Remove the factory tailpipe from the vehicle by disengaging the exhaust system hanger pins from the rubber hangers using a large screw-driver or pry bar.

*NOTE: Lubricating the rubber hangers with WD-40 or similar lubricant will ease removal of the hanger pins.*

**5.** Remove the factory muffler from the vehicle by removing the three (3) nuts from the factory exhaust flange located at the factory muffler inlet.

**6.** Locate the supplied intermediate pipe and cut the intermediate pipe based on the following configurations.

See **Table 1**. Cut the NON-flanged end of the intermediate pipe. See **Figure 2**.

**7.** Install the Banks intermediate pipe and 3-bolt gasket onto the headpipe. Loosely assemble with the supplied bolts, washers, and nuts.

**8.** Slide the supplied 4" exhaust hanger clamp onto the outlet of the Banks flanged intermediate pipe. Insert the hanger pin into the factory rubber hanger.

**9.** Route the Front Tailpipe over the rear axle housing and install the Front Tailpipe onto the Banks Intermediate pipe outlet. Loosely snug the rear hanger clamp.

**10.** Install the 4" exhaust clamp onto the inlet of the Rear Tailpipe. Start the Rear tailpipe hanger pin into the corresponding vehicle rubber hanger. Position the rubber hanger as shown in **Figure 3**. Install the Rear Tailpipe over the outlet of the Front Tailpipe. Slide the 4" clamp into position that best supports the tailpipe assembly. Loosely snug the hanger clamp on the intermediate pipe outlet.

**11.** Adjust the Tailpipe Tip under the rear fender such that the tip position is aesthetically pleasing.

*NOTE: Maintain an adequate air gap clearance of one (1) inch between the exhaust and the shock absorber and between the exhaust and the spare tire.*

**12.** With everything positioned properly, begin to tighten the clamps starting with the ones closest to the turbo and working your way back. Evenly torque the exhaust clamps to 35 ft-lbs. Make sure that each slip is fully inserted (+/- 1/4 inch).

**13.** Remove the protective covering from the tailpipe tip.

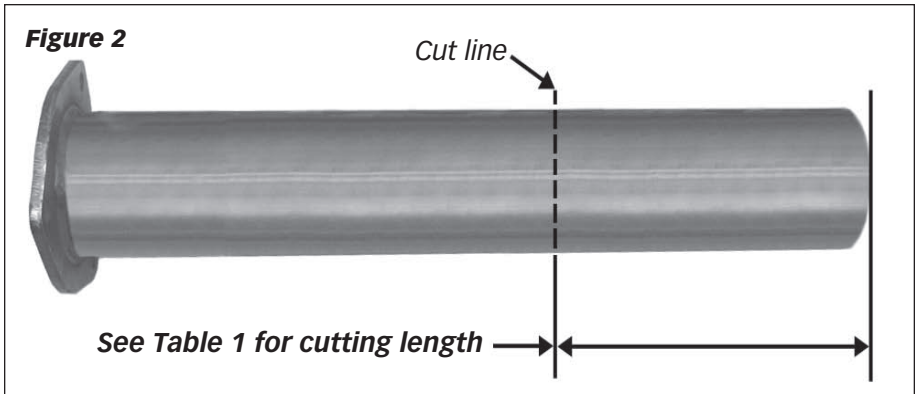

**Table 1**

<b>2011 Ford Power Stroke 6.7L</b>		
	Wheel Base	Cut this length from the Intermediate Pipe. See <b>Figure 2</b> .
Crew Cab/ Short Bed F-250/350	156.2"	16.25"
Crew Cab/ Long Bed F-250/350	172.4"	No Cut
Crew Cab/ Long Bed F-450	172.4"	1.5"

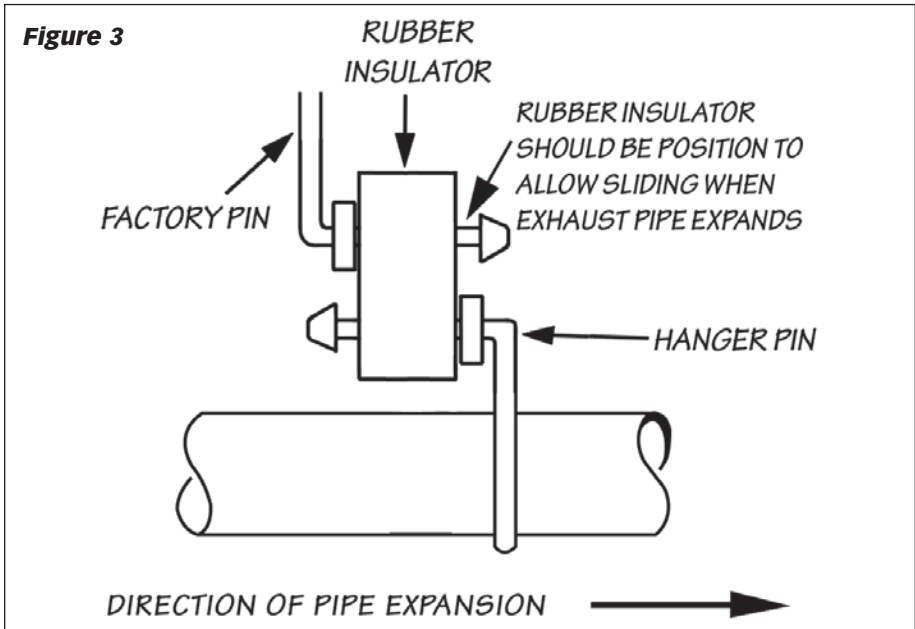

**Figure 4**



**CAUTION: THE PROTECTIVE COVERING MAY IGNITE AND BURN IF NOT REMOVED PRIOR TO RUNNING THE ENGINE.**

**14.** Your system includes two “Banks Power” logos designed to complement the Ford badging on your truck. See

**Figure 4** to position the logos for a clean factory look.

**15.** Re-connect battery terminals if previously removed. Banks Monster Exhaust installation is now complete.