

banks

Owner's Manual with Installation Instructions

Banks TorqueTube® System

2004-2008 Ford 5.4L F-150 (Late Body Style)

THIS MANUAL IS FOR USE WITH SYSTEMS 48715

BANKS

General Installation Practices

- 1.** For ease of installation of you Banks system, familiarize yourself with the procedure by reading the entire manual before starting work.
- 2.** The exploded views provide only general guidance. Refer to each step and section diagram in this manual for proper instruction.
- 3.** Throughout this manual, the left side of the vehicle refers to the driver's side, and the right side to the passenger's side.
- 4.** Disconnect the ground cables from the battery before beginning work. If the vehicle has more than one battery, be sure that the engine primary battery is disconnected. This is necessary for safety and to ease the installation of the passenger side TorqueTube® exhaust manifold.
- 5.** Route and tie wires and hoses a minimum of 6 inches away from exhaust heat, moving parts and sharp edges. Clearance of 8 inches or more is recommended where possible.

- 6.** When raising the vehicle, support it on properly weight-rated safety stands, ramps or a commercial hoist. Follow the manufacturer's safety precautions. Take care to balance the vehicle to prevent it from slipping or falling. When using ramps, be sure the front wheels are centered squarely on the topsides; put the transmission in park; set the hand brake; and place blocks behind the rear wheels. If the vehicle is supported by a hoist, the front wheels may be removed for further accessibility.

CAUTION! Do not use floor jacks to support the vehicle while working under it. Do not raise the vehicle onto concrete blocks, masonry or any other item not intended specifically for this use.

- 7.** During installation, keep the work area clean. If foreign debris is transferred to any Banks component. Clean it thoroughly before installing.

Tools Required

- 10mm ratchet wrench
 - 10mm swivel socket
 - 5mm 6 point socket
 - Clean shop towels or rags
 - Pry bar or channel lock pliers
 - 1/4" and 3/8" drive ratchets with metric sockets and a 1/4" drive extension
 - Metric combination or open-end wrenches
 - Standard and Phillips head screwdrivers
 - Penetrating oil or light lubricant spray
- Table of Contents

TorqueTube Installation

1. With the vehicle in neutral, safely raised, ground wire(s) disconnected, and precautions in place, remove the factory exhaust system.

2. To provide better access to the manifolds remove the front wheels from the vehicle. If the vehicle is equipped with inner front fender shields, remove them for improved access.

Note: Before removing the lug nuts, make sure a capable torque wrench is available to tighten the lug nuts to the manufacturer's torque specifications

3. Disconnect the four (4) oxygen sensors connectors on the y-pipe from the vehicle harness.

4. Remove the factory y-pipe from the vehicle by removing the four (4) bolts attaching the factory manifolds to the exhaust. Remove the two (2) bolts on the y-pipe support hanger bracket. Loosen the clamp on the y-pipe outlet. Remove the y-pipe from the vehicle. See **Figure 1**.

5. Begin to remove both exhaust manifolds by backing each nut away from the cylinder heads at least one turn, then use a 5mm 6-point socket to remove each stud from the heads. As an alternate method, remove the nuts from the studs and then remove the studs.

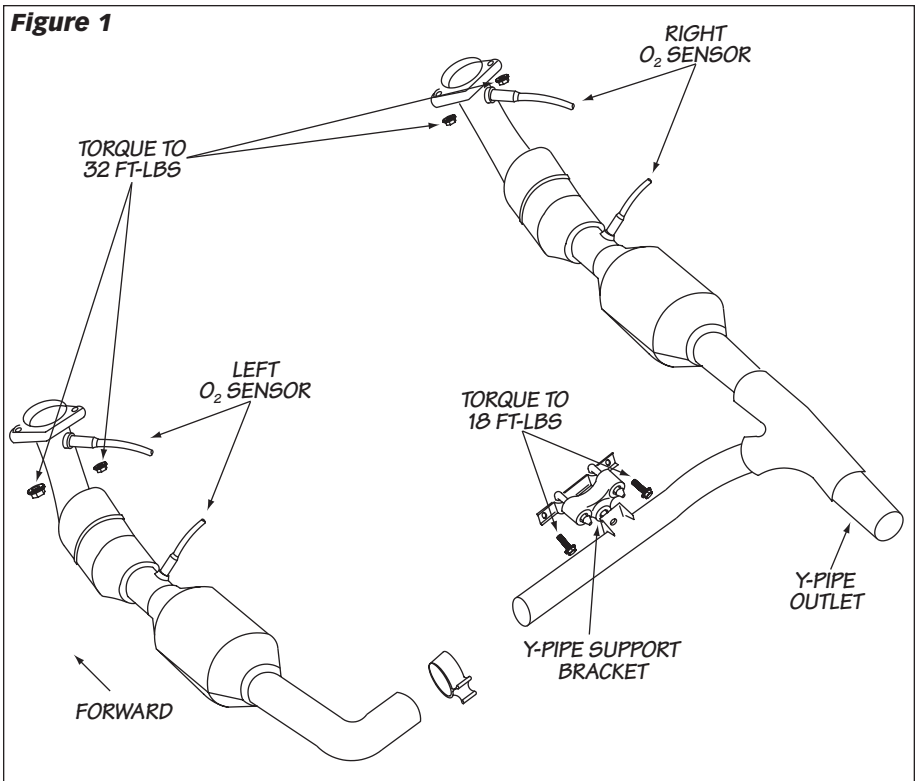

6. Remove the driver side manifold by lowering the manifold under the truck on the inside of the frame rail. Remove the dipstick tube by removing the 10mm bolt that bolts the dipstick to the head (retain bolt for re-use in **step 11**). Use a small hammer to tap the arm on the dipstick upward and it will come out of the block. If your vehicle is equipped with four-wheel drive, disengage the forward coupling of the front drive shaft from the front axle by removing the four bolts at the flange. This will allow clearance for the installation of the TorqueTube. Retain the hardware for reassembly.

7. To remove the passenger side manifold, the AC dryer will need to loosen. From the inside of the engine bay, remove the battery and remove the nuts on the AC dryer bracket from the firewall.

8. Loosen and remove the starter. Be sure the Battery is disconnected. See **Figure 2** for the assembly view. Remove the passenger-side manifold from the vehicle. Be careful not to scrape the manifold on the aluminum head.

9. Inspect the exhaust mounting surfaces of the cylinder heads and clean away any deposits to assure proper sealing of the Banks TorqueTubes. Be careful when doing this as the cylinder heads are aluminum and can be easily damaged. Use of a plastic scraper to clean the aluminum surface is recommended.

10. Place a small amount of anti-seize compound on the threads of each of the supplied 16-manifold bolts. When installing the bolts be careful not to cross thread in the aluminum threads of the cylinder head.

Figure 2

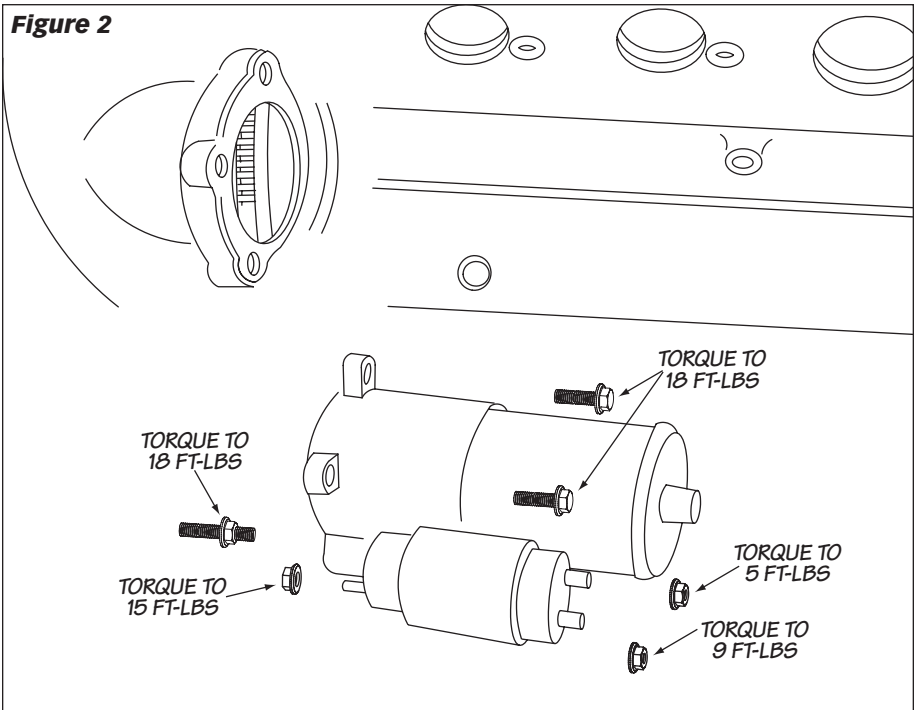

11. Install the driverside TorqueTube from underneath the vehicle. Install the TorqueTube and gasket onto the head. Be sure the gasket is properly aligned as the exhaust ports are not centered. Retain the TorqueTube with eight (8) of the supplied 8mm bolts. Torque bolts to 20 ft-lbs in the sequence shown in **Figure 3**. Re-install the dipstick between the 2 and 3 ports on the head and guide it into the hole on the block. You can use a small hammer and a small screw driver to tap it all the way into the hole and then re-use the bolt that was removed in **step 6** and bolt it to the original location on the head.

12. Install the passenger side TorqueTube through the rear of the front wheel-well, lift the AC dryer filter to allow for clearance. See **Figure 4**. Place the gasket on the cylinder head and thread the two (2) rear upper bolts about 1/2-way into the cylinder head. Slide the TorqueTube slotted bolt flange on the two (2) rear bolts and install the remaining bolts onto the TorqueTube and gasket assembly.

Retain the TorqueTube with eight (8) of the supplied 8mm bolts. Torque bolts to 20 ft-lbs in the sequence shown in **Figure 3**.

13. Reconnect the starter to engine. Refer to **Figure 2** for torque specs.

14. Reinstall the factory y-pipe to the vehicle by attaching the y-pipe outlet to the exhaust system, place the factory clamp on the y-pipe outlet. Reattach the two (2) bolts on the y-pipe support hanger bracket and Torque to 18 ft-lbs.

15. Bolt the two (2) floating flanges of the factory head-pipes to the outlet of the TorqueTubes using the supplied 3/8"–16 bolts, washers and nuts. Insert the bolt up through the flange of the y-pipe and through the Torque Tube flange, with one washer on the head of the bolt and a washer under the nut.

Evenly torque 3/8" hardware to 32 ft-lbs. Torque the clamps to 18 ft-lbs. See **Figure 1**.

Figure 3

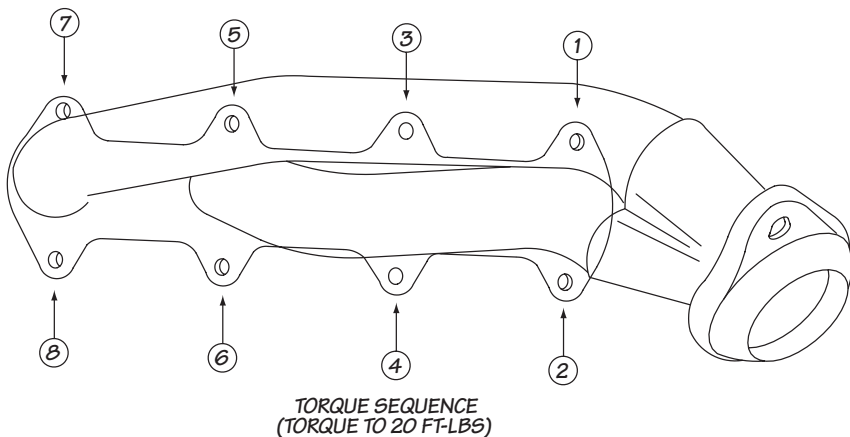
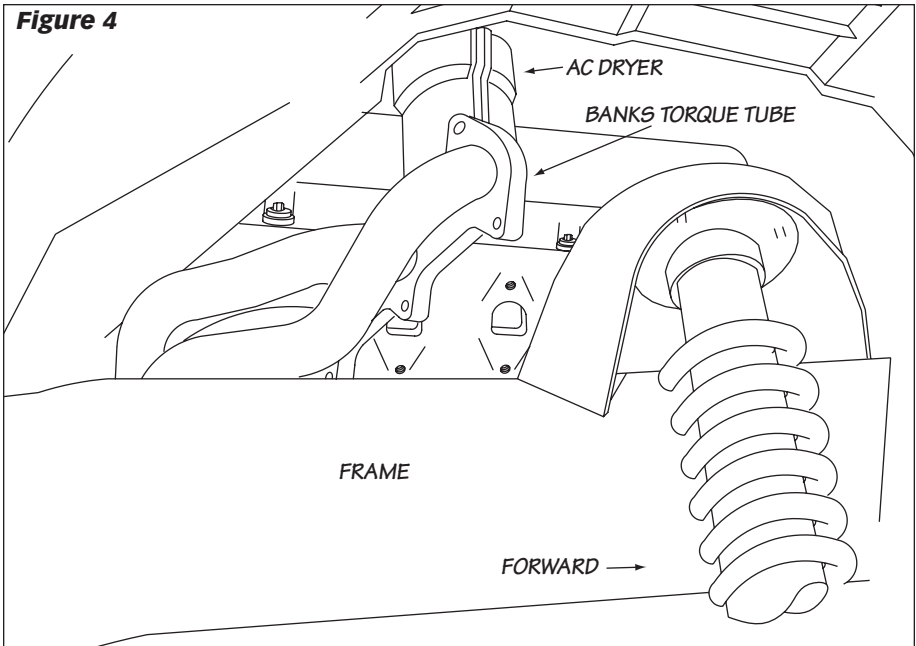

Figure 4



16. Reconnect the four (4) oxygen sensors connectors on the y-pipe to the vehicle harness. Reinstall the forward coupling of the front 4x4 drive shaft to the front axle if previously removed. Reinstall the starter. See **Figure 2** for the assembly view.

17. Zip-tie any cables or harnesses away from the Torque Tubes. Banks recommends a minimum of 6" away from exhaust. Reinstall the AC dryer and install the battery and battery terminals.

18. Your system includes two (2) "Banks Power" logos designed to complement the Ford emblems on the vehicles front fenders. Use the provided measurements for a clean factory look (see **Figure 5**).

19. Start the engine and listen for exhaust leaks. Tighten the Torque Tubes and exhaust clamps as necessary. The Banks TorqueTube installation is now complete.

Figure 5

