

**banks**

with Installation Instructions

# Owner's Manual

## **Banks Monster® Exhaust System**

**2003-2004 Dodge 5.9L Cummins  
ISB Pickup Trucks**

THIS MANUAL IS FOR USE WITH MONSTER EXHAUST,  
SYSTEMS 48640, 48641, 48642 & 48643

**banks**

# Also Available from Banks Power

03-07 Dodge 5.9L



## **Banks iQ System (P/N 61148-61149)**

- 5" touchscreen interface that can control the Banks Diesel Tuner on the fly.
- Interchangeable gauge display, read and clear codes, monitor engine diagnostics, log data, time your vehicles runs and much more.

## **Banks Ram-Air Intake System (P/N 42145)**

- Increases your airflow over stock.
- Adds power, improves fuel economy, lowers EGTs and reduces smoke.

## **Banks Ram-Air Intake Super-Scoop (P/N 42190-42191)**

- Adds cooler denser air to the Ram-Air Intake housing, further increasing fuel economy, reducing smoke and lowers EGTs.

## **Banks Monster-Ram (P/N 42765-42766)**

- Increased flow from intercooler
- Raises boost without increasing backpressure at the turbine

## **Big Hoss Intake Manifold System (P/N 42747)**

- Increases flow and provides more uniform air distribution to the engine for more available power at a given boost level.

## **Banks Techni-Cooler® System (P/N 25980-25981)**

- Provides increased air flow to the engine by increasing air density for more increased power, lower EGTs and improved fuel economy.

## **Banks Exhaust Brake (P/N 55222-55229)**

- Increases the stopping power of your truck and extends the service life of your brakes

## **Banks SmartLock (P/N 55270)**

- Reduces wear on transmission
- Locks Torque Converter and raises trans-line pressure
- Works with Banks Exhaust Brake

**Banks Billet Torque Converter  
(P/N 72515)**

- Higher torque capacity over stock
- Lockup clutch is slip-resistant so transmission fluids stay cooler and transmission life is prolonged.

**Banks Bullet  
(P/N 66522-66523)**

- Adds power safely to your vehicle
- Displays critical engine functions
- Engine safeguards
- Change power levels on-the-fly

**Boost and Pyro Gauges  
(P/N 64507)**

- Keep your engine safe by monitoring vital engine parameters.

**Banks Diesel Tuner  
EconoMind w/switch (P/N 63725,  
63793, 63795, 64507)  
EconoMind w/iQ (P/N 63807, 63808,  
63817, 63818)**

**Six-Gun w/switch (P/N 61022, 63797)  
Six-Gun w/iQ (P/N 63809, 63819)**

- Adds power safely to your vehicle
- Engine and transmission safeguards
- Change power levels on-the-fly

**Thermocouple**

- Add a temperature limiting function to your Diesel Tuner .

**Banks Speed-Loader  
(P/N 62981)**

- Furthers the power output of the Banks Six-Gun and provides EGT limiting safety.

**Banks BigHead® Actuator  
(P/N 24331)**

- Achieves a higher peak boost over stock and gives you precise boost control that gives you crisp acceleration and more mid-range pulling power.

**Banks Stinger Systems  
(P/N 49692-49699, 49708-49711,  
49716-49721)**

**Contains:**

- Ram-Air Intake system
- Monster Exhaust (single or dual)
- EconoMind Tuner w/ Banks iQ
- Big Head Wastegate Actuator

**Banks PowerPack Systems  
(P/N 49700-49707, 49712-49715,  
49722-49727)**

**Contains:**

- Ram-Air Intake system
- Monster Exhaust (single or dual)
- EconoMind Tuner w/ Banks iQ
- Big Head Wastegate Actuator
- Monster-Ram
- Techni-Cooler System

**Banks Six-Gun Bundle  
(P/N 49728-49735, 49744-49747,  
49752-49757)**

**Contains:**

- Ram-Air Intake system
- Monster Exhaust (single or dual)
- Six-Gun Tuner w/ Banks iQ
- Big Head Wastegate Actuator

**Banks Big Hoss Bundle  
(P/N 49736-49743, 49748-49751,  
49758-49763)**

**Contains:**

- Ram-Air Intake system
- Monster Exhaust (single or dual)
- Six-Gun Tuner w/ Banks iQ
- Big Head Wastegate Actuator
- Monster-Ram
- Techni-Cooler System

# General Installation Practices

**1.** For ease of installation of your Banks system, familiarize yourself with the procedure by reading the entire manual before starting work.

**2.** The exploded view (**Figure 1**) provides only general guidance. Refer to each step and section diagram in this manual for proper instruction.

**3.** Throughout this manual, the left side of the vehicle refers to the driver's side, and the right side to the passenger's side.

**4.** Disconnect the ground cable from the battery (or batteries, if there are two) before beginning work.

**5.** Route and tie wires and hoses a minimum of 6" away from exhaust heat, moving parts and sharp edges. Clearance of 8" or more is recommended where possible.

**6.** When raising the vehicle, support it on properly weight-rated safety stands, ramps or a commercial hoist. Follow the manufacturer's safety precautions. Take care to balance the vehicle to prevent it from slipping or falling. When using ramps, be sure the

front wheels are centered squarely on the topsides; put the transmission in park; set the hand brake; and place blocks behind the rear wheels.

**Caution! Do not use floor jacks to support the vehicle while working under it. Do not raise the vehicle onto concrete blocks, masonry or any other item not intended specifically for this use.**

**7.** During installation, keep the work area clean. Do not allow anything to be dropped into intake, exhaust, or lubrication system components while performing the installation, as foreign objects will cause immediate engine damage upon start-up.

## Tools Required:

- 1/2" and 3/8" drive ratchets with inch and metric sockets and 1/2" and 3/8" drive extension
- Inch and metric combination or open-end wrenches
- Standard screwdriver
- Clean shop towels or rags
- Pry-bar
- Reciprocating saw

## Highly recommended tools and supplies:

- Inch-pound and foot-pound torque wrenches
- Compressed air source and hose
- Air pressure regulator
- Penetrating oil or light lubricant spray

# Monster Exhaust System Installation

1. As a precaution, disconnect the ground of the battery (if there is more than one battery, disconnect both).
2. Raise the vehicle and support it with properly weight rated safety stands, ramps or a commercial hoist. Follow the manufacturer's safety precautions. Take care to balance the vehicle to prevent it from slipping or falling. When using ramps, be sure the front wheels are centered squarely on the topsides; place the transmission in park; set the parking brake and place blocks behind the rear wheels. **CAUTION: DO NOT WORK UNDER ANY VEHICLE SUPPORTED ONLY BY A JACK. SEVERE INJURY MAY RESULT.**

**WARNING! The following step requires the use of a torch and/or saw. Proper safety equipment should be used. Failure to use proper safety equipment may result in severe injury.**

3. From under the vehicle, remove the entire factory exhaust system. Starting at the rear of the vehicle, remove each component by either cutting through the pipe near the clamps or by removing the clamps and heating the joints with an oxy-acetylene torch to allow crimped pipes to separate. **DO NOT CUT OR DAMAGE CATALYTIC CONVERTER TUBING DURING THE REMOVAL PROCESS.** Remove the hanger pins from the rubber hangers with a pry bar. (Spray lubricant will ease hanger removal.)
4. Remove the clamp attaching the turbine outlet pipe (T.O.P) to the catalytic converter headpipe (or intermediate pipe if applicable) and remove the catalytic converter assembly or intermediate pipe. Remove the band-clamp that attaches the T.O.P. to the turbine outlet elbow and remove the factory T.O.P from the vehicle.

5. Remove the V-band clamp that attaches the turbine outlet elbow to the turbine housing and remove the turbine outlet elbow from the vehicle.
6. Attach the supplied T.O.P. gasket to the Banks T.O.P. Loosely place the supplied V-band clamp on the Banks T.O.P. Install the Banks T.O.P. to the turbine housing (note: the factory turbine outlet elbow will not be used). Loosely snug the V-band clamp assuring gasket and T.O.P are aligned properly.
7. *For vehicles that are NOT equipped with a catalytic converter,* install the supplied Banks front intermediate pipe and supplied gasket onto the previously installed Banks T.O.P. Place a small amount of anti-seize onto the four (4) 7/16" bolts. Loosely install the supplied 7/16" hardware onto the T.O.P. and intermediate pipe flange (see **Figure 1**). Proceed to **Step 9**.

8. *For vehicles equipped with catalytic converters:*

**IMPORTANT: If the vehicle is equipped with a catalytic converter, it should be inspected. Diesel catalysts may become plugged with soot and can cause a restriction to exhaust flow, impeding performance. Shine a powerful flashlight into the inlet end of the converter. Observe the light through the other end of the converter. The full circle of the flashlight should be visible without any blockage in the gridwork of the catalyst. If excessive soot is observed, the catalyst may need to be cleaned. TAKE PRECAUTIONS to avoid blowing soot toward the work area or where it could be inhaled. ALWAYS use breathing protection. Also inspect the catalyst for damage (i.e. chips, bent corners, etc.) to the gridwork.**

# General Assembly Diagram

Figure 1

Item	Description	P/N	QTY.
1	Monster Turbine Outlet Pipe (T.O.P.)	53270	1
2	Front Intermediate Pipe, (Non-Cat. Conv. System Only)	53272	1
3	Front Intermediate Pipe (Cat. Conv. Systems Only)	53271	1
4	Rear Intermediate Pipe	53273	1
5	Extension Pipe	53276	1
6	Muffler	53801	1
7	Tailpipe Assembly	53275	1
8	Tailpipe Tip Assembly	52377	1
9	V-Band clamp, 4"	92887	1
10	Gasket, Turbine Outlet	93005	1
11	Gasket, Exhaust Flange	93210	1
*12	Exhaust Clamp, 4"	52470	2
13	Exhaust Clamp, 3.5" (Cat. Conv. Systems Only)	52468	1
14	Hex Bolt, 7/16"x 20-1.50	91629	4

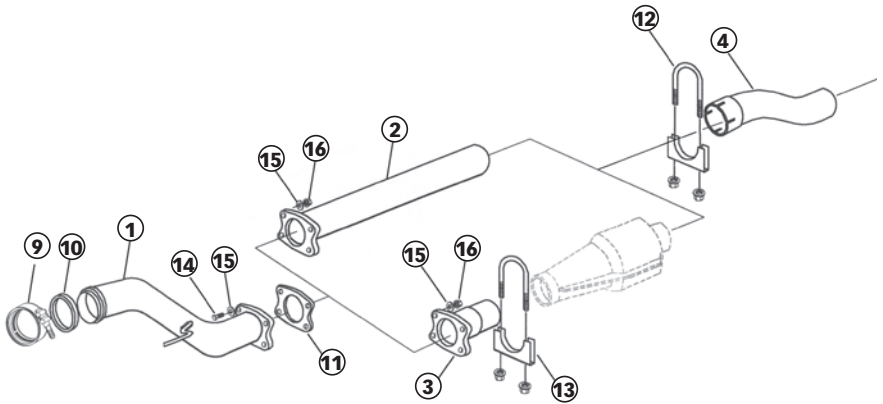

Item	Description	P/N	QTY.
15	Washer, Flat 7/16-AN, S/S	91601	8
16	Nut, Crimplock 7/16"-20	91619	4
17	Hanger Clamp, Front Muffler	53279	1
18	Hanger Clamp, Rear Muffler	53280	1
19	Urocal, Banks Power	96009	2

\* Quad-Cab, Long Bed Models contain three (3) 4" exhaust clamps.

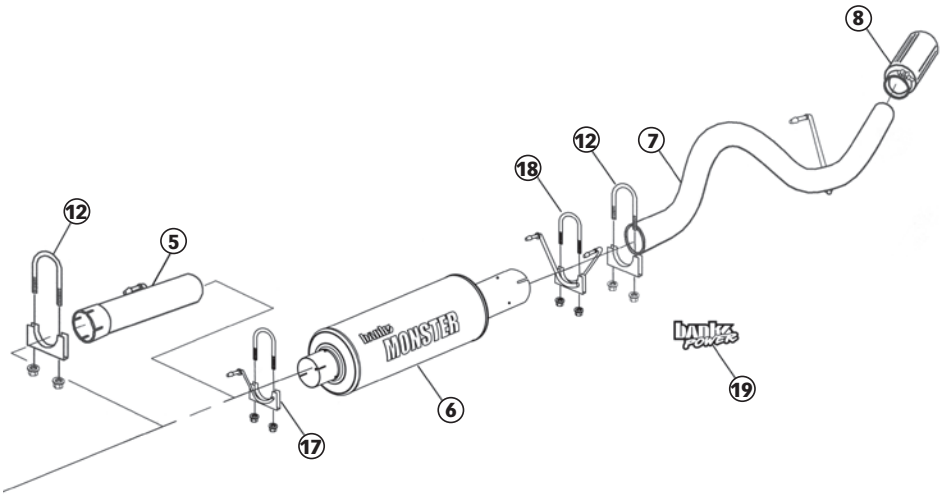

**If your catalytic converter is damaged, it may be covered under your vehicle's emissions warranty.**

**A)** With the catalytic converter removed from the vehicle and the headpipe removed from the converter, measure 13" inward from the outlet tubing rim (3-1/2" of tubing from the outlet weld should remain). Using a reciprocating saw or equivalent, vertically cut and remove 13" from the converter outlet tubing (see **Figure 2**).

**B)** Install the supplied Banks front intermediate pipe and supplied gasket onto the previously installed Banks T.O.P. Place a small amount of anti-seize onto the four (4) 7/16" bolts. Loosely install the supplied 7/16" hardware onto the T.O.P. and intermediate pipe flange.

**C)** Install the supplied 3-1/2" clamp onto the catalytic converter inlet. Place the catalytic converter onto the previously installed intermediate pipe. Loosely snug the clamp on the catalytic converter inlet.

**9.** Place a supplied 4" clamp onto the front of the supplied intermediate pipe. Install the intermediate pipe onto the catalytic converter outlet or the front intermediate pipe. Lightly snug the exhaust clamp near the rim of the intermediate pipe.

**10.** For quad cab long bed (160.5" wheelbase) models only: Place a supplied 4" clamp onto the front of the supplied extension pipe. Install the extension pipe hanger pin into the corresponding rubber hanger. Connect the extension pipe onto the intermediate pipe and loosely snug the 4" clamp.

**11.** Install the front hanger clamp onto the Monster Muffler inlet. Install the muffler inlet onto the intermediate pipe. With the hanger facing the front of the vehicle, insert the front hanger into the vehicle's rubber grommet.

**12.** Install the rear hanger clamp onto the Monster Muffler outlet with the hanger pins facing forward. Install the two (2) rear hanger pins into the vehicle's rubber grommets. Orient the Banks Monster logo to be level with the frame rail. Install a 4" clamp onto the muffler outlet. Route the tailpipe over the rear axle housing and into the muffler outlet. Install the tailpipe hanger pin into the corresponding rubber hanger.

**13.** Install the 5" Monster tailpipe tip on the exhaust. Keep the wrapping on until installation is complete. The tip should be rotated so the clamp nut is pointing down. For a fleet-side truck the 5" tip should be hung 1" past

**Figure 2**

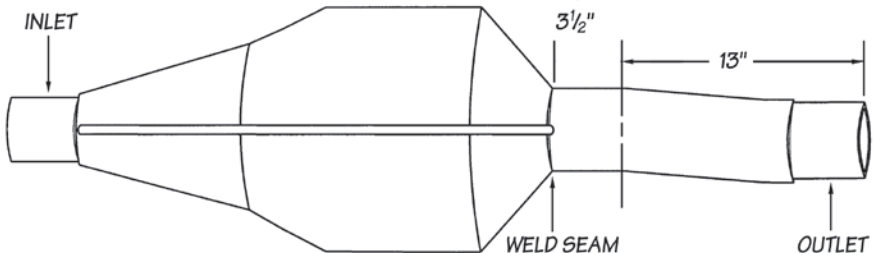



the end of the tailpipe. For a dually, the tip should be 3-1/2" past the end of the tailpipe or where aesthetically pleasing.

**14.** With everything positioned properly, begin to tighten the clamps starting with the ones closest to the turbo and working your way back. Torque the V-band clamp to 80 in-lbs (not ft-lbs). Evenly torque the exhaust clamps to 35 ft-lbs. Torque the 7/16" hardware to 48 ft-lbs. Make sure that each slip is fully inserted (+/- 1/4 inch) and that all mount hangers are in the forward position (see **Figure 3**).

**15.** Remove the protective covering from the tailpipe tip. **Caution: The protective covering may ignite and burn if not removed prior to running the engine.**

**16.** Your system includes two (2) Banks power logos. The logos can be mounted 1/2" to 1" above the "Cummins Turbo Diesel" emblem on the driver-side and passenger-side front fenders.

**17.** Re-connect battery terminals if previously removed. Banks Monster Exhaust installation is now complete.

**Figure 3**

