

banks

with Installation Instructions
Owner's Manual

**Banks Monster[®]
Exhaust System**

2007-2009 Toyota FJ Cruiser

THIS MANUAL IS FOR USE WITH MONSTER EXHAUST SYSTEMS 48141, 48142

banks

General Installation Practices

1. Before starting work, familiarize yourself with the installation procedure by reading all of the instructions.
2. The exploded view (**Figure 2**) provides only general guidance. Refer to each step and section diagram in this manual for proper instruction.
3. Throughout this manual, the left side of the vehicle refers to the driver's side, and the right side to the passenger's side.
4. Disconnect the negative (ground) cable from the battery (or batteries, if there are two) before beginning work.
5. Route and tie wires and hoses a minimum of 6" away from exhaust heat, moving parts and sharp edges. Clearance of 8" or more is recommended where possible.
6. When raising the vehicle, support it on properly weight-rated safety stands, ramps or a commercial hoist. Follow the manufacturer's safety precautions. Take care to balance the

vehicle to prevent it from slipping or falling. When using ramps, be sure the front wheels are centered squarely on the topsides; put the transmission in park; set the hand brake; and place blocks behind the rear wheels.

Caution! Do not use floor jacks to support the vehicle while working under it. Do not raise the vehicle onto concrete blocks, masonry or any other item not intended specifically for this use.

7. During installation, keep the work area clean. Do not allow anything to be dropped into intake, exhaust, or lubrication system components while performing the installation, as foreign objects will cause immediate engine damage upon start-up.

Tools Required:

- 1/2" and 3/8" drive ratchets with standard and metric sockets and 1/2" and 3/8" drive extension
- Standard and metric combination or open-end wrenches
- Standard screwdriver
- Clean shop towels or rags
- Pry-bar

Highly recommended tools and supplies:

- Foot-pound torque wrench
- Penetrating oil or light lubricant spray

Monster Exhaust

SYSTEM INSTALLATION

1. Disconnect the negative (ground) cable from the battery (if there is more than one battery, disconnect both negative cables). Secure the cable so it cannot accidentally come in contact with the post.

2. Raise the vehicle and support it securely with properly weight-rated safety stands, ramps or a commercial hoist. Take care to balance the vehicle to prevent it from slipping or falling. When using ramps, be sure the wheels are centered squarely on the topsides. Place the transmission in park (automatic), set the parking brake and securely block the wheels that are on the ground.

CAUTION: DO NOT WORK UNDER ANY VEHICLE SUPPORTED ONLY BY A JACK. SEVERE INJURY MAY RESULT.

3. From under the vehicle remove the factory exhaust starting at the 2-bolt flange in front of the muffler. Remove the two (2) bolts, two (2) washers, and two (2) springs from the flange and retain for re-use.

NOTE: Remove the factory gasket from the 2-bolt flange. The exhaust system will be hanging by the exhaust hanger pins.

4. Liberally apply an aerosol lubricant on all the hanger pins. Remove the exhaust system from the vehicle by removing each hanger pin from the rubber grommet.

NOTE: Remove hanger pins from the front of the vehicle to the rear.

5. Drop the exhaust system to the floor and move out of the way. You will not be reusing any components from the exhaust system.

6. Install the Banks conical gasket onto the vehicle's 2-bolt flange.

7. Install the hanger pin on the intermediate pipe into the corresponding rubber grommet. Install the Banks intermediate pipe onto the factory 2-bolt intermediate pipe outlet using the factory hardware. See **Figure 1**. When tightening the

Figure 1

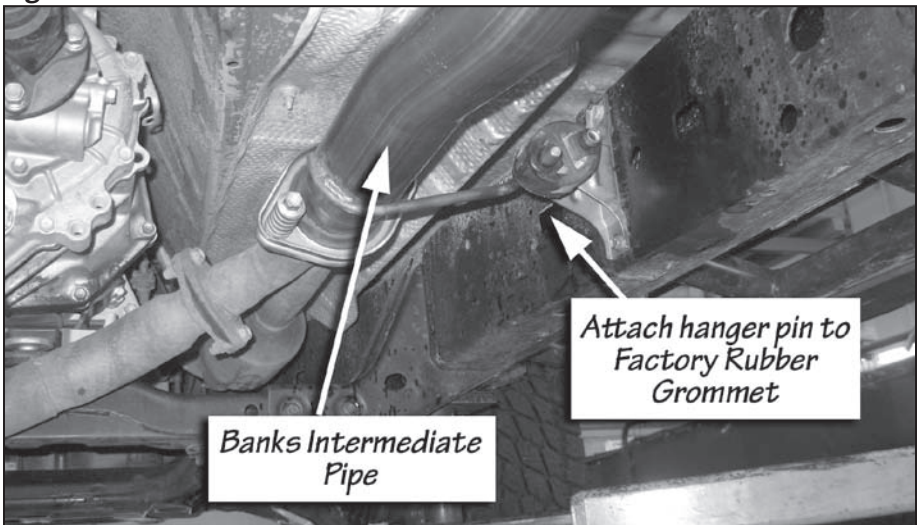

General Assembly

Figure 2

Item	Description	Part #	Qty
1	Conical Seal Gasket	93098	1
2	Intermediate Pipe	53195	1
3	Single Hanger Clamp, Front Muffler	53196	1
4	Banks Monster Muffler	53962	1
5	Dual Hanger Clamp, Rear Muffler	53197	1
6	Tailpipe	53198*	1
7	Tailpipe	53199*	1
8	Banks Power Urocal	96009	2

* System 48141 uses 53198 & System 48142 uses 53199

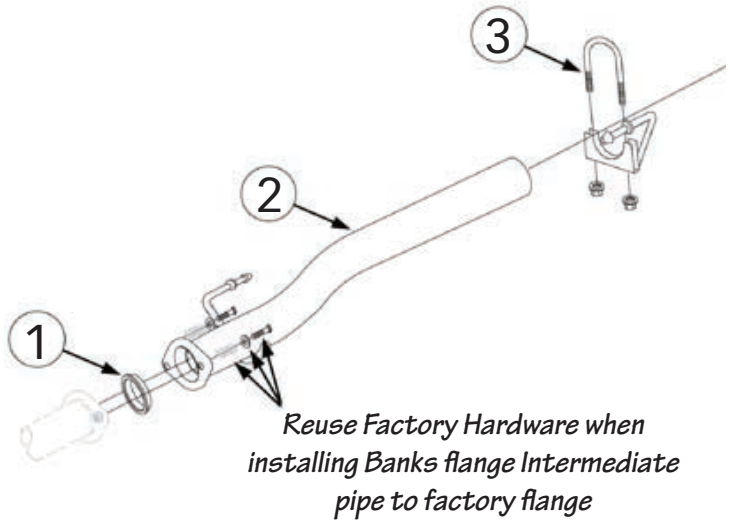

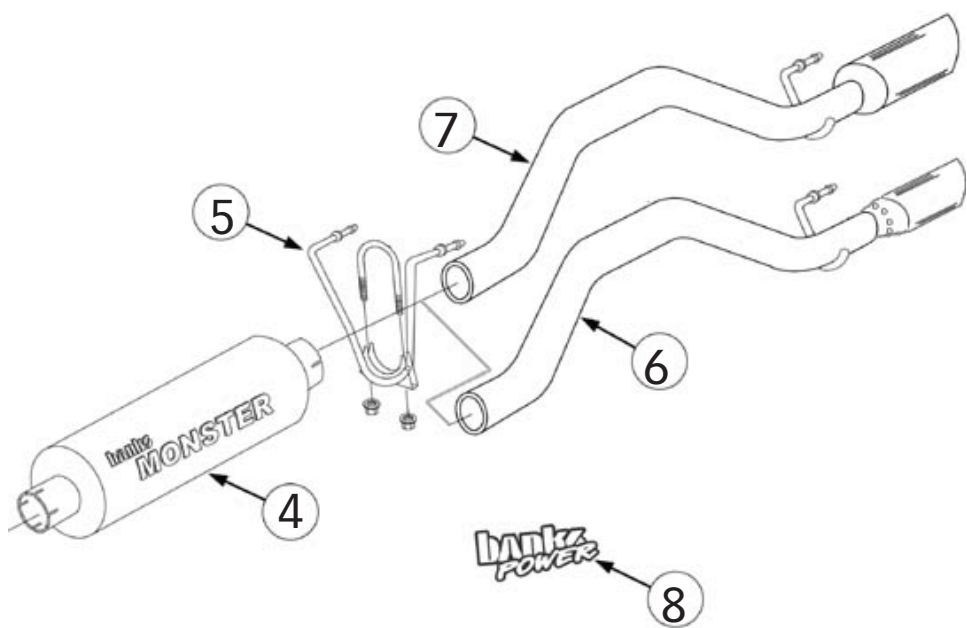

hardware, tighten the bolt such that 2-threads remain on the bolt before bottoming to the flange. The tension spring will keep the bolt secured (see **Figure 3**).

8. Install the single pin hanger clamp onto the outlet of the Intermediate pipe such that the hanger pin is facing the front. Insert the hanger pin into the vehicles corresponding rubber grommet.

NOTE: Once the pipe / muffler has been completely engaged in the slip joint, mark the pipe with scribe or tape for reference when tightening the clamps later in the installation. Mark each slip joint in this fashion.

9. Install the Banks Monster Muffler inlet onto the intermediate pipe (Note the inlet labeling of the muffler). Orient the Monster logo such that is visible from the passenger side and parallel with the frame rail. Align the hanger clamp onto the muffler inlet.

NOTE: All clamps should be positioned at the beginning of the slots (on the 1/2 circle punch) and evenly tightened.

10. Install the 3" dual pin hanger clamp onto the Banks Muffler outlet such that the hanger pins are facing the rear of the vehicle. Install the two (2) hanger pins into the vehicles corresponding rubber grommets (see **Figure 4**).

11. From the vehicle rear, route the tailpipe over the rear cross member. Start the tailpipe hanger pin into the corresponding vehicle rubber hanger. Install the tailpipe into the Banks Muffler outlet. Lightly tighten the rear muffler hanger clamp to secure the tailpipe (see **Figure 5**).

12. Adjust the Tailpipe Tip 1/2" under the rear bumper such that the tip position is aesthetically pleasing.

13. With the exhaust positioned properly, begin to tighten the clamps starting with the ones closest to the front of the vehicle and working your way back. Torque the exhaust clamps evenly to 35 ft-lbs. Make sure that each slip is fully inserted (+/- 1/4").

14. Remove the protective covering from the tailpipe tip.

Figure 3

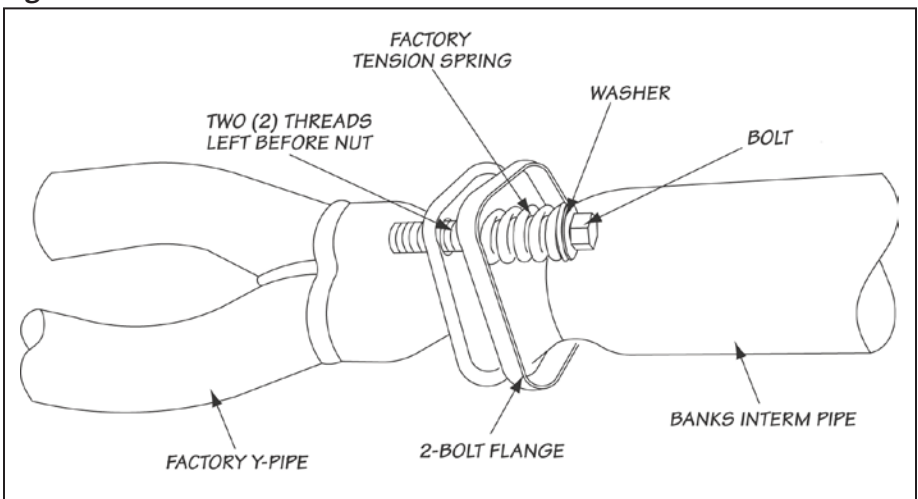

CAUTION: THE PROTECTIVE COVERING MAY IGNITE AND BURN IF NOT REMOVED PRIOR TO RUNNING THE ENGINE.

15. Your system includes two (2) Banks Power logos designed to complement the Toyota FJ Cruiser on the vehicles front fenders or front doors.

16. Re-connect the negative battery cable. Start the engine and listen for exhaust leaks. Tighten the exhaust clamps as necessary. Whenever possible, tack weld slip connections to prevent disengagement is recommended. The Banks Monster Exhaust installation is now complete.

Figure 4

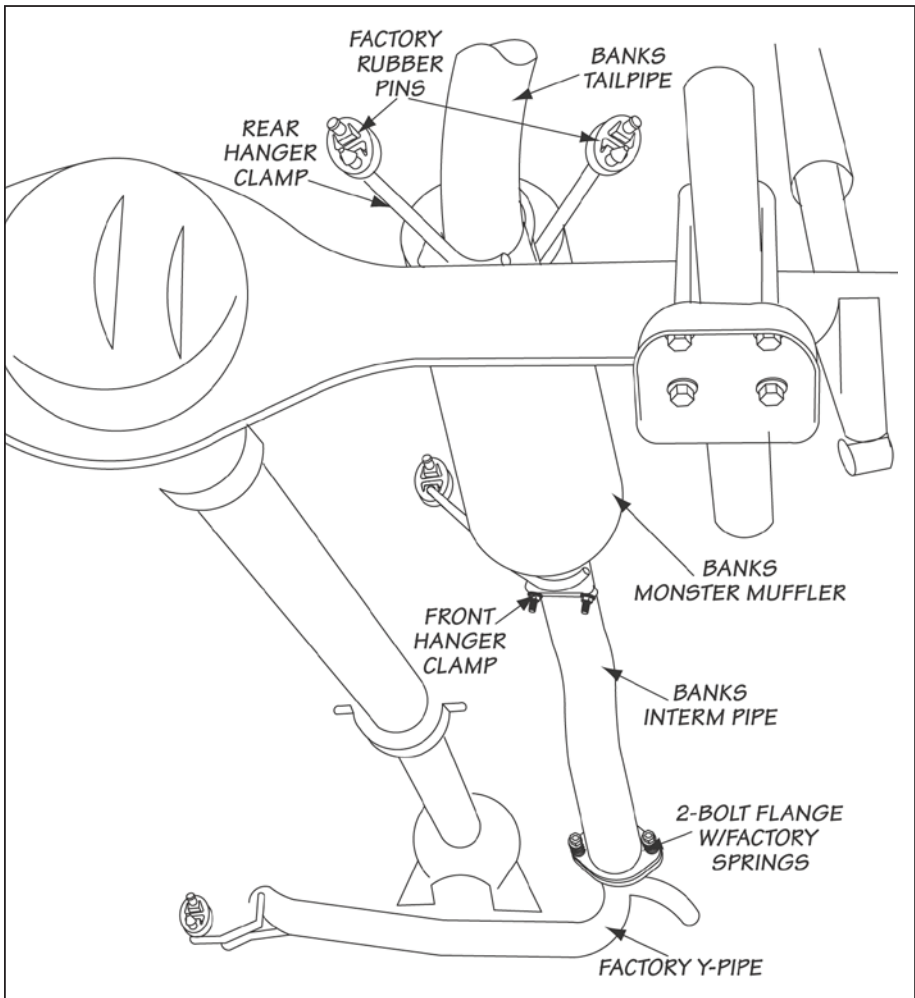

Figure 5- System 48142 shown

