

banks

with Installation Instructions
Owner's Manual

**Banks Monster[®]
Exhaust System**

**2009-2010 Toyota Tundra 5.7L
Double Cab Standard Bed**

THIS MANUAL IS FOR USE WITH MONSTER EXHAUST SYSTEMS 48140

banks

General Installation Practices

1. Before starting work, familiarize yourself with the installation procedure by reading all of the instructions.
2. The exploded view (**Figure 2**) provides only general guidance. Refer to each step and section diagram in this manual for proper instruction.
3. Throughout this manual, the left side of the vehicle refers to the driver's side, and the right side to the passenger's side.
4. Disconnect the negative (ground) cable from the battery (or batteries, if there are two) before beginning work.
5. Route and tie wires and hoses a minimum of 6" away from exhaust heat, moving parts and sharp edges. Clearance of 8" or more is recommended where possible.
6. When raising the vehicle, support it on properly weight-rated safety stands, ramps or a commercial hoist. Follow the manufacturer's safety precautions. Take care to balance the

vehicle to prevent it from slipping or falling. When using ramps, be sure the front wheels are centered squarely on the topsides; put the transmission in park; set the hand brake; and place blocks behind the rear wheels.

Caution! Do not use floor jacks to support the vehicle while working under it. Do not raise the vehicle onto concrete blocks, masonry or any other item not intended specifically for this use.

7. During installation, keep the work area clean. Do not allow anything to be dropped into intake, exhaust, or lubrication system components while performing the installation, as foreign objects will cause immediate engine damage upon start-up.

Tools Required:

- 1/2" and 3/8" drive ratchets with standard and metric sockets and 1/2" and 3/8" drive extension
- Standard and metric combination or open-end wrenches
- Standard screwdriver
- Clean shop towels or rags
- Pry-bar
- Hacksaw or similar Electric cutting tool

Highly recommended tools and supplies:

- Foot-pound torque wrench
- Penetrating oil or light lubricant spray
- Reciprocating saw

Monster Exhaust System Installation

1. Disconnect the negative (ground) cable from the battery (if there is more than one battery, disconnect both negative cables). Secure the cable so it cannot accidentally come in contact with the post.

2. Raise the vehicle and support it securely with properly weight-rated safety stands, ramps or a commercial hoist. Take care to balance the vehicle to prevent it from slipping or falling. When using ramps, be sure the wheels are centered squarely on the topsides. Place the transmission in park (automatic), set the parking brake and securely block the wheels that are on the ground.

CAUTION: DO NOT WORK UNDER ANY VEHICLE SUPPORTED ONLY BY A JACK. SEVERE INJURY MAY RESULT.

3. From under the vehicle remove the factory exhaust bolts located on both flanged Y-Pipes. Keep the removed bolts. They will be reused in a later step.

NOTE: Remove the factory gaskets. The exhaust system will be hanging by the hanger clamps.

4. Liberally apply an aerosol lubricant on all the hanger pins. Remove the exhaust system from the vehicle by removing each hanger pin from the rubber insulator.

NOTE: Remove pins from front of vehicle to rear.

5. Drop the exhaust system to the floor and move out of the way. You will not be reusing any components from the exhaust system.

WARNING! The following steps may require the use of a torch and/or saw. Proper safety equipment should be used. Failure to use proper safety equipment may result in severe injury.

6. Measure 16-¹/₄" from the left flange connection forward following the right side of the pipe and marking the location on the left factory intermediate pipe as shown in **Figure 1**.

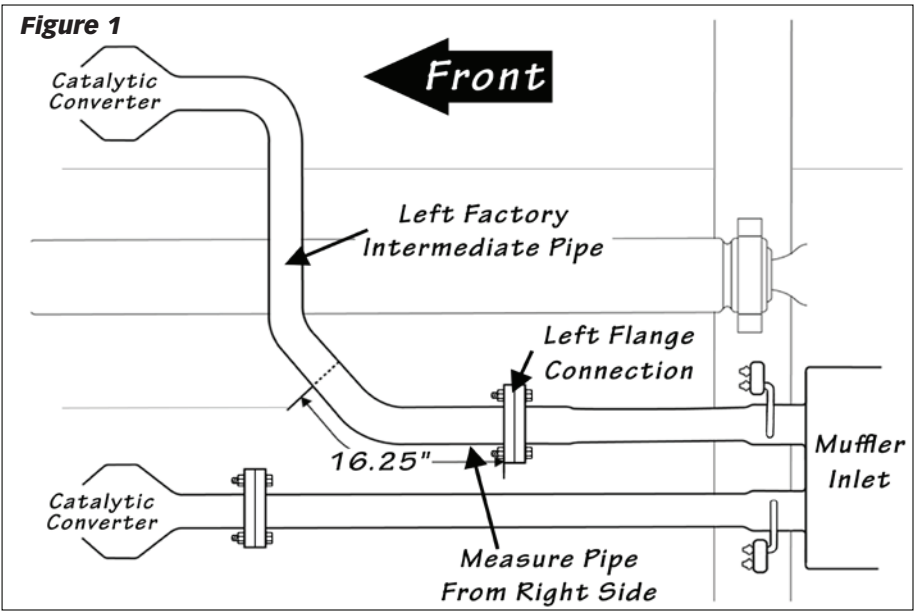

General Assembly

Figure 2

Description	P/N	QTY
1 Ring Seal	93167	1
2 Y-pipe	53267	1
3 Intermediate Pipe	53253	1
4 Sliding Hanger Clamp, 3"	53256	1
5 Exhaust Clamp, 3"	52465	2
6 Monster 3" Muffler	54005	1
7 Hanger Clamp, rear muffler	53257	1
8 Tail Pipe	53258	1
9 Exhaust Clamp, 2.5"	52461	1
10 Banks Uroclals	96009	2

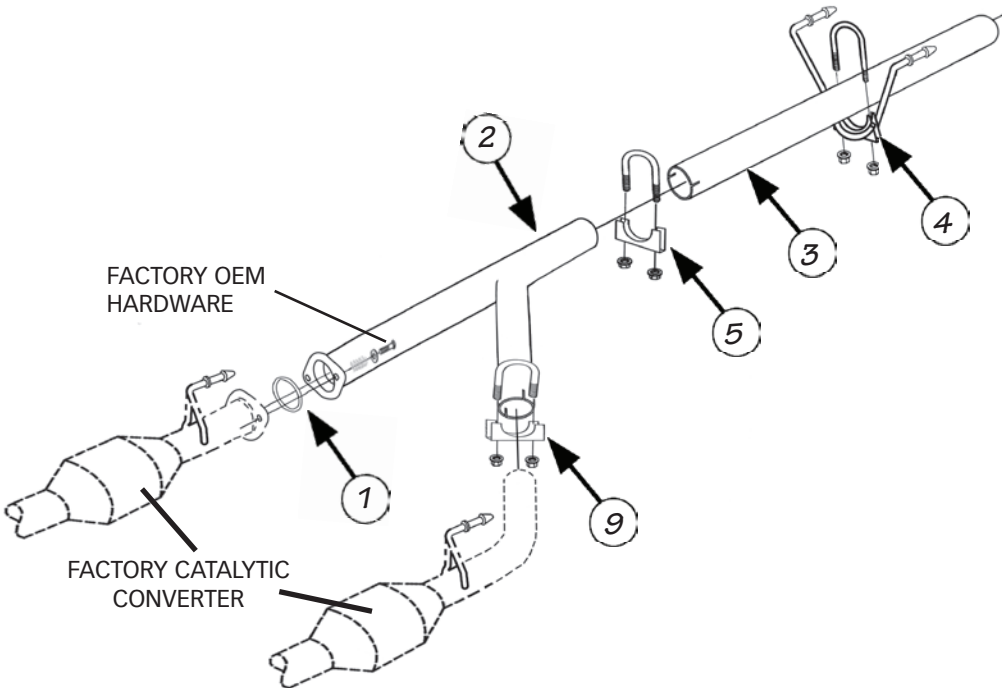

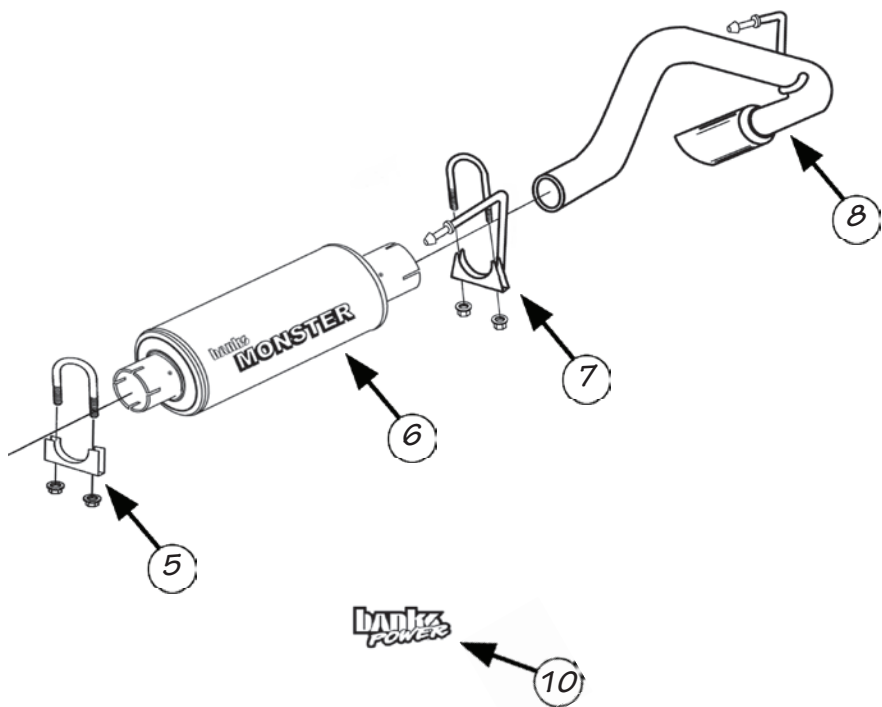

7. Cut the pipe using a hacksaw or similar electric cutting tool at the mark location. Take time when measuring and cutting the factory outlet pipe to ensure the proper location and a straight cut. Improper cut will result in poor fitment of the Banks Monster exhaust system.

8. Install a 2- $\frac{1}{2}$ " clamp on the left factory intermediate pipe outlet. Install the Banks Y-pipe flange connection and supplied ring gasket onto the factory intermediate pipe flange connection and then insert the Y-pipe slip joint over the left factory intermediate pipe. Lightly tighten the 2- $\frac{1}{2}$ " clamp over the Y-pipe left inlet and re-use the factory hardware to tighten the factory flange connection to the Y-pipe flange.

9. Locate the supplied intermediate pipe and cut the intermediate pipe 19" from the NON-swaged end of the intermediate pipe. See **Figure 3**.

10. Locate and install the intermediate pipe swaged end onto the Banks Y-pipe outlet. Install a 3" saddle clamp onto the swaged end and loosely tighten. Slide on the sliding hanger clamp onto the intermediate pipe such that the hanger pins face the rear of the vehicle. Install the clamp hanger pins into the corresponding vehicle rubber insulators and loosely tighten the clamp.

*NOTE: When installing hanger pins into rubber insulators make sure that the pin is pushed properly into place. See **Figure 4**.*

11. Install the 3" exhaust clamp onto the inlet of the Banks Monster Muffler (*Note: the inlet labeling of the muffler*). Orient the "Monster" logo such that it is parallel with the frame rail. Install the Banks Muffler inlet onto the intermediate pipe and lightly tighten the 3" clamp.

*NOTE: All clamps should be positioned at the beginning of the slots (on the $\frac{1}{2}$ circle punch) and evenly tightened. See **Figure 5**.*

12. Install the 3" rear muffler hanger clamp onto the Banks Muffler outlet such that the hanger pin face forward. Install the clamp hanger pin into the corresponding vehicle rubber insulators. See **Figure 4**.

13. From the vehicle rear, route the tailpipe over the rear end. Start the tailpipe hanger pin into the corresponding vehicle rubber hanger. Install the tailpipe into the Banks Muffler outlet. Lightly tighten the rear muffler hanger clamp to secure the tailpipe. See **Figure 6**.

14. Adjust the Tailpipe Tip under the rear fender such that the tip position is aesthetically pleasing.

Figure 3

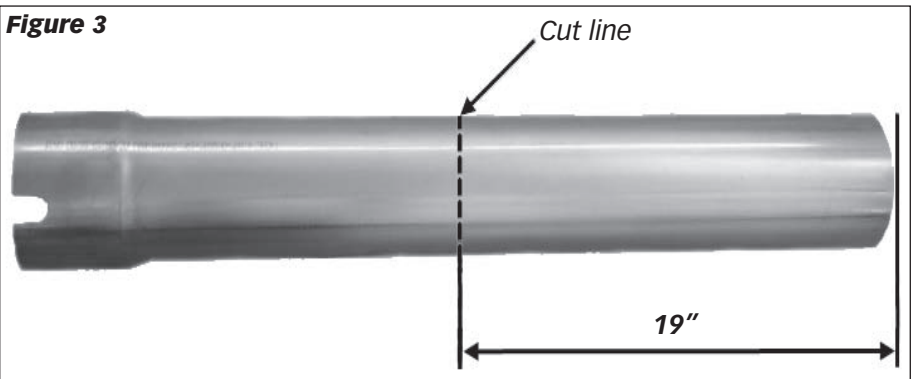

15. With the exhaust positioned properly, begin to tighten the clamps starting with the ones closest to the front of the vehicle and working your way back. Torque the exhaust clamps evenly to 35 ft-lbs. Make sure that each slip is fully inserted ($\pm 1/4"$). See **Figure 5**.

16. Remove the protective covering from the tailpipe tip.

Caution: the protective covering may ignite and burn if not removed prior to running the engine.

17. Your system includes two (2) Banks Power logos designed to complement the Toyota Tundra emblems on the vehicles front doors. Use the provided measurements for a clean factory look (see **Figure 7**).

18. Re-connect the negative battery cable. Start the engine and listen for exhaust leaks. Tighten the exhaust clamps as necessary. Whenever possible, tack weld slip connections to prevent disengagement is recommended. The Banks Monster Exhaust installation is now complete.

Figure 4

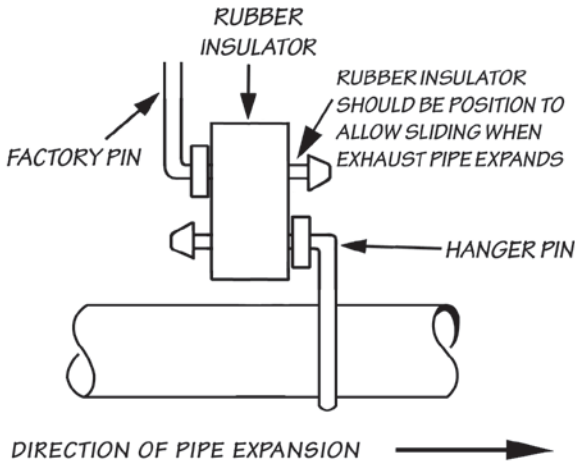

Figure 5

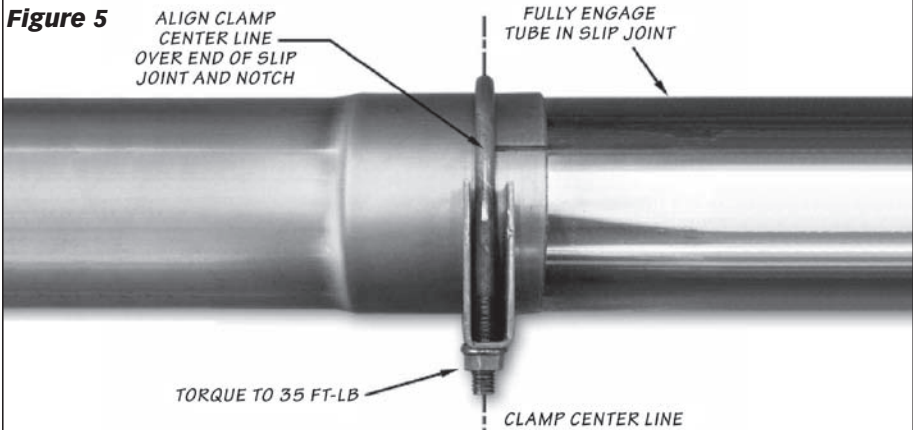

Figure 6

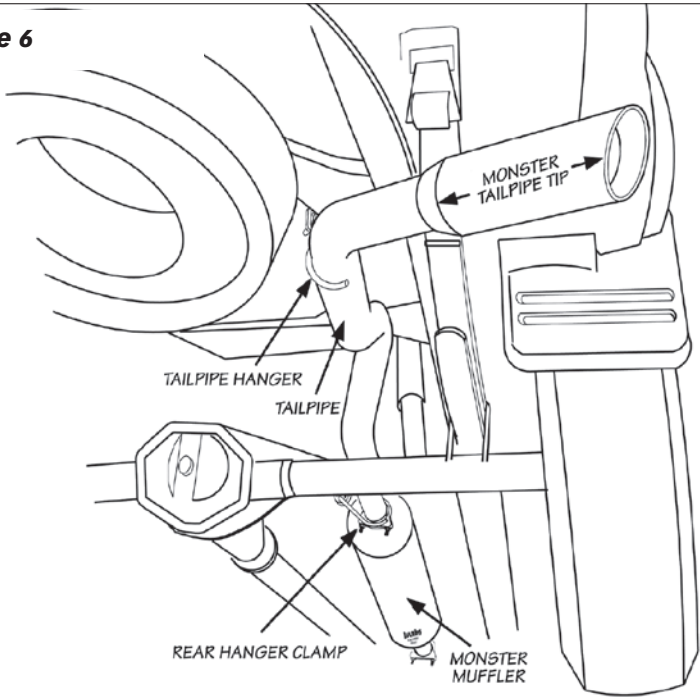

Figure 7

