

banks

with Installation Instructions
Owner's Manual

**Banks Monster®
Exhaust System**

2005-2008 Nissan Frontier 4.0L

THIS MANUAL IS FOR USE WITH SYSTEM 48125 & 48126

banks

General Installation Practices

1. Before starting work, familiarize yourself with the installation procedure by reading all of the instructions.
2. The exploded view (**Figure 1**) provides only general guidance. Refer to each step and section diagram in this manual for proper instruction.
3. Throughout this manual, the left side of the vehicle refers to the driver's side, and the right side to the passenger's side.
4. Disconnect the negative (ground) cable from the battery (or batteries, if there are two) before beginning work.
5. Route and tie wires and hoses a minimum of 6" away from exhaust heat, moving parts and sharp edges. Clearance of 8" or more is recommended where possible.
6. When raising the vehicle, support it on properly weight-rated safety stands, ramps or a commercial hoist.

Follow the manufacturer's safety precautions. Take care to balance the vehicle to prevent it from slipping or

falling. When using ramps, be sure the front wheels are centered squarely on the topsides. When raising the front of the vehicle, put the transmission in park (automatic) or reverse (manual), set the parking brake, and block the rear wheels. When raising the back of the vehicle, be sure the vehicle is on level ground and the front wheels are blocked securely. **Caution! Do not use floor jacks to support the vehicle while working under it. Do not raise the vehicle onto concrete blocks, masonry or any other item not intended specifically for this use.**

7. During installation, keep the work area clean. Do not allow anything to be dropped into intake, exhaust, or lubrication system components while performing the installation, as foreign objects will cause immediate engine damage upon start-up.

TOOLS REQUIRED:

- 1/2" and 3/8" drive ratchets with standard and metric sockets and 1/2" and 3/8" drive extension
- Standard and metric combination or open-end wrenches
- Standard screwdriver
- Clean shop towels or rags
- Pry-bar

Highly recommended tools and supplies:

- Foot-pound torque wrench
- Penetrating oil or light lubricant spray

General Assembly Diagram

Figure 1

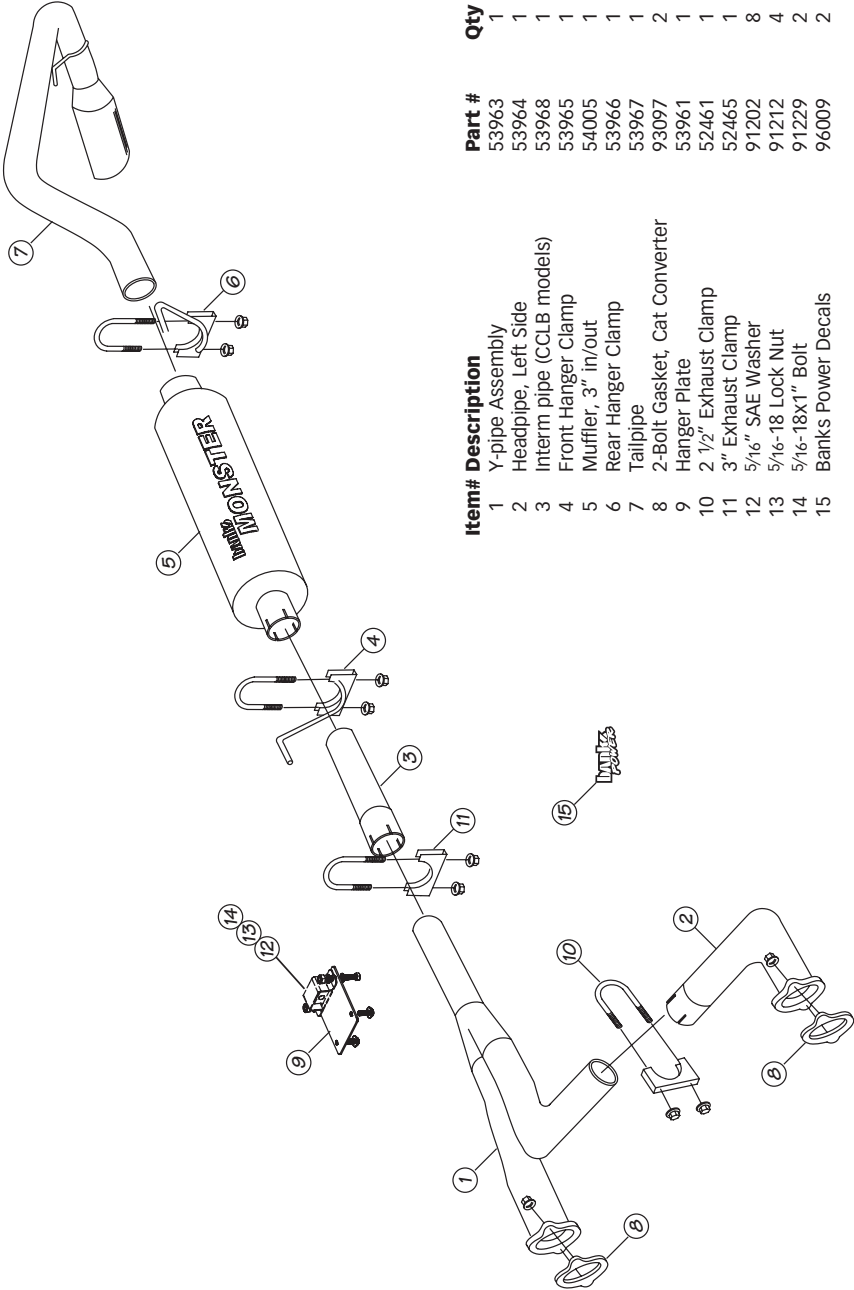

Item#	Description	Part #	Qty
1	Y-pipe Assembly	53963	1
2	Headpipe, Left Side	53964	1
3	Interm pipe (CCLB models)	53968	1
4	Front Hanger Clamp	53965	1
5	Muffler, 3" in/out	54005	1
6	Rear Hanger Clamp	53966	1
7	Tailpipe	53967	1
8	2-Bolt Gasket, Cat Converter	93097	2
9	Hanger Plate	53961	1
10	2 1/2" Exhaust Clamp	52461	1
11	3" Exhaust Clamp	52465	1
12	5/16" SAE Washer	91202	8
13	5/16-18 Lock Nut	91212	4
14	5/16-18x1" Bolt	91229	2
15	Banks Power Decals	96009	2

Monster Exhaust System Installation

1. Disconnect the negative (ground) cable from the battery (if there is more than one battery, disconnect both negative cables). Secure the cable so it cannot accidentally come in contact with the post.

2. Raise the vehicle and support it securely with properly weight-rated safety stands, ramps or a commercial hoist. Take care to balance the vehicle to prevent it from slipping or falling. When using ramps, be sure the wheels are centered squarely on the topsides. Place the transmission in park (automatic) or reverse (manual), set the parking brake and securely block the wheels that are on the ground.

CAUTION: DO NOT WORK UNDER ANY VEHICLE SUPPORTED ONLY BY A FLOOR JACK. SEVERE INJURY MAY RESULT.

WARNING! The following step may require the use of a torch and/or saw. Proper safety equipment should be used. Failure to use proper safety equipment may result in severe injury.

3. From under the vehicle remove the factory exhaust starting at the rear of the catalytic converter. Remove the exhaust by removing the four (4) nuts on the 2-bolt flanges connecting the y-pipe to the catalytic converters. Retain the factory nuts for reassembly.

4. Support the exhaust at the tailpipe. Remove the three (3) rubber hanger supports from the body / frame by removing the two (2) M8x1.25 bolts on each rubber hanger. Retain all hardware and rubber grommets for reassembly.

5. Remove the two (2) ground straps on the factory exhaust system. Remove the muffler and Y-pipe assembly from the vehicle. Remove the gaskets from the 2-bolt flanges.

6. Remove the rubber vibration dampener from the factory tailpipe.

7. Install the factory rubber vibration dampener onto the Banks tailpipe such that the dampener is facing forward (see **Figure 2**). Install using two $\frac{5}{16}$ " bolts, two $\frac{5}{16}$ " nuts and four $\frac{5}{16}$ " washers. Do not tighten as a ground strap will later be attached.

8. Align the factory rubber hanger onto the Banks hanger plate and secure with the supplied $\frac{5}{16}$ " bolts, nuts and washers (see **Figure 3**).

9. Align the hanger plate assembly onto the original location of the hanger such that the rubber hanger is on top of the plate. Loosely reinstall the two (2) factory bolts through hanger plate into the vehicle frame.

10. Attach the remaining two (2) rubber hangers onto the original vehicle body / frame locations. Use the factory 8mm hardware to secure.

11. Install the two (2) gaskets onto the 2-bolt catalytic converter flanges. Install the Y-pipe flange onto the right side catalytic converter flange. Lightly tighten the factory two (2) M8x1.25 nuts onto the factory studs.

12. Install a 2-1/2" clamp onto the left side headpipe. Install the left headpipe slip fitting into the Y-pipe assembly. Install the headpipe flange onto the left side catalytic converter flange. Reinstall the ground strap onto the right factory stud and lightly tighten the two (2) factory M8x1.25 nuts onto the factory studs (see **Figure 4**).

13. For Crew-Cab Long Bed models only, install a 3" saddle clamp onto the inlet of the supplied intermediate pipe. Install the Intermediate pipe onto the y-pipe outlet. Lightly tighten the 3" clamp.

Figure 2

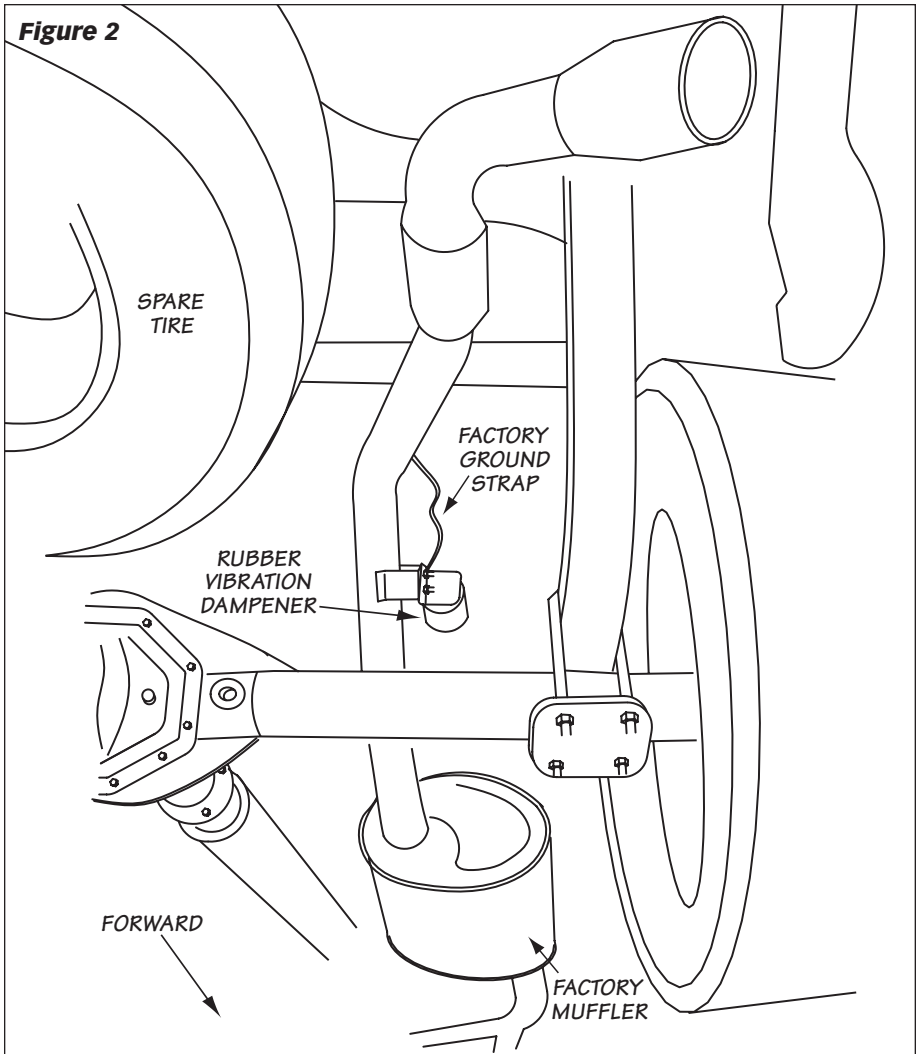

14. Install the 3" hanger clamp onto the inlet of the Monster Muffer. The hanger pin on the clamp will be facing forward on the right side of the clamp. Install the Monster Muffer onto the Y-pipe assembly. Note the Monster Muffer inlet labeling. Insert the front hanger clamp pin into the rubber hanger on the Banks hanger plate.

15. Install the 3" hanger clamp onto the Monster Muffer outlet. The hanger pin on the clamp will be facing forward and to the left side of the clamp. Insert the rear hanger clamp pin into the vehicle's rubber hanger.

Figure 3

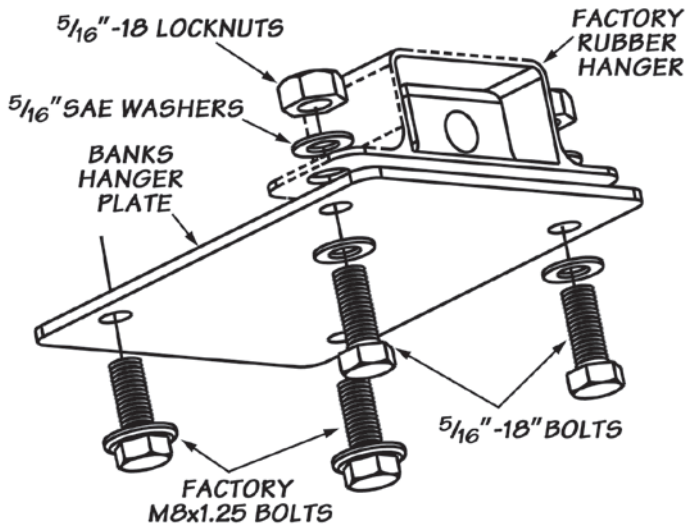
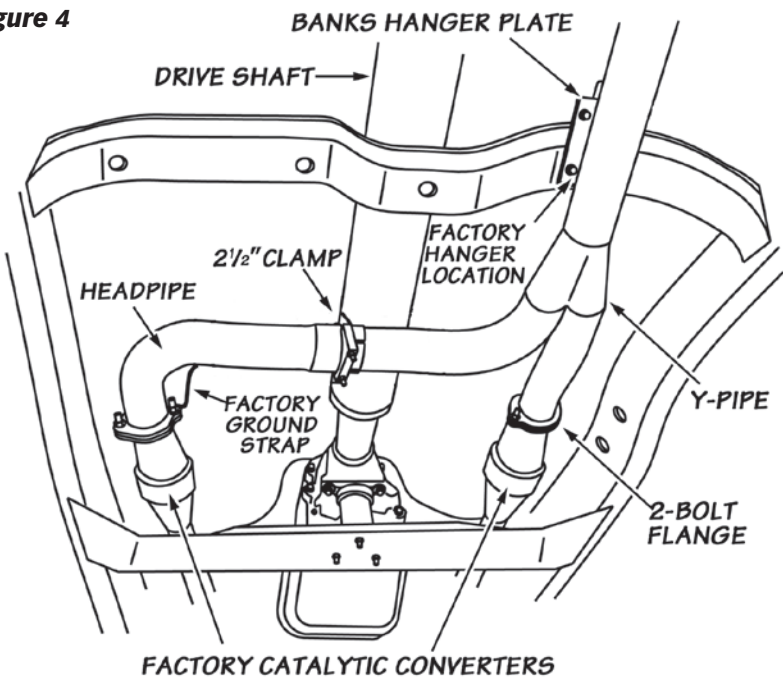

Figure 4



16. From the vehicle rear, route the tailpipe over the rear axle. Start the tailpipe hanger pin into the vehicle's rubber hanger. Install tailpipe into the Banks Muffler.

17. Adjust the tip about 1/2" under the body panel.

18. Install the ground strap onto the rubber vibration dampener located on the Banks tailpipe.

19. With the exhaust positioned properly, begin to tighten the clamps and hardware starting with the ones to the front of the vehicle and working your way back. Torque the exhaust clamps evenly to 35 ft-lbs. Make sure that each slip is fully inserted (+/-1/4"). Torque the factory M8 hardware to 22 ft-lbs. Torque the 5/16" hardware to 19 ft-lbs.

20. Remove the protective covering from the tailpipe tip. **Caution: the protective covering may ignite and burn if not removed prior to running the engine.**

21. Your system includes two (2) "Banks Power" logos designed to complement the Nissan emblems on the vehicles front fenders

22. Re-connect the negative battery cable. Start the engine and listen for exhaust leaks. Tighten the exhaust clamps as necessary. Whenever possible, tack weld slip connections to prevent disengagement is recommended.

23. The Banks Monster Exhaust installation is now complete.