

**banks**

with Installation Instructions  
**Owner's Manual**

**Banks Monster<sup>®</sup>  
Exhaust System**

**2007-2010 Chevy/GMC 6.6L LMM Duramax  
Turbo-Diesel Pickups**

THIS MANUAL IS FOR USE WITH SYSTEM 47784

**banks**

# General Installation Practices

1. Before starting work, familiarize yourself with the installation procedure by reading all of the instructions.
2. The exploded view (**Figure 1**) provides only general guidance. Refer to each step and section diagram in this manual for proper instruction.
3. Throughout this manual, the left side of the vehicle refers to the driver's side, and the right side to the passenger's side.
4. Disconnect the negative (ground) cable from the battery (or batteries, if there are two) before beginning work.
5. Route and tie wires and hoses a minimum of 6" away from exhaust heat, moving parts and sharp edges. Clearance of 8" or more is recommended where possible.
6. When raising the vehicle, support it on properly weight-rated safety stands, ramps or a commercial hoist.

Follow the manufacturer's safety precautions. Take care to balance the vehicle to prevent it from slipping or falling. When using ramps, be sure the front wheels are centered squarely on the topsides; put the transmission in park; set the hand brake; and place blocks behind the rear wheels.

**Caution! Do not use floor jacks to support the vehicle while working under it. Do not raise the vehicle onto concrete blocks, masonry or any other item not intended specifically for this use.**

7. During installation, keep the work area clean. Do not allow anything to be dropped into intake, exhaust, or lubrication system components while performing the installation, as foreign objects will cause immediate engine damage upon start-up.

## Tools Required:

- 1/2" and 3/8" drive ratchets with standard and metric sockets and 1/2" and 3/8" drive extension
- Standard and metric combination or open-end wrenches
- Standard screwdriver
- Clean shop towels or rags
- Pry-bar

## Highly recommended tools and supplies:

- Foot-pound torque wrench
- Penetrating oil or light lubricant spray
- Oxy-acetylene torch

**Figure 1** Banks Monster Exhaust, General Assembly

Item #	Description	Part #	QTY
1	Flange Intermediate Pipe	53748	1
2	Front Tailpipe	53758	1
3	Rear Tailpipe	53757	1
4	Hanger Clamp	53753	1
5	Clamp	52470	1
6	Nut	91619	3
7	Washer	91602	6
8	Gasket, Intermediate	93211	1
9	Bolt	91628	3
10	Banks Urocalcs	96009	2

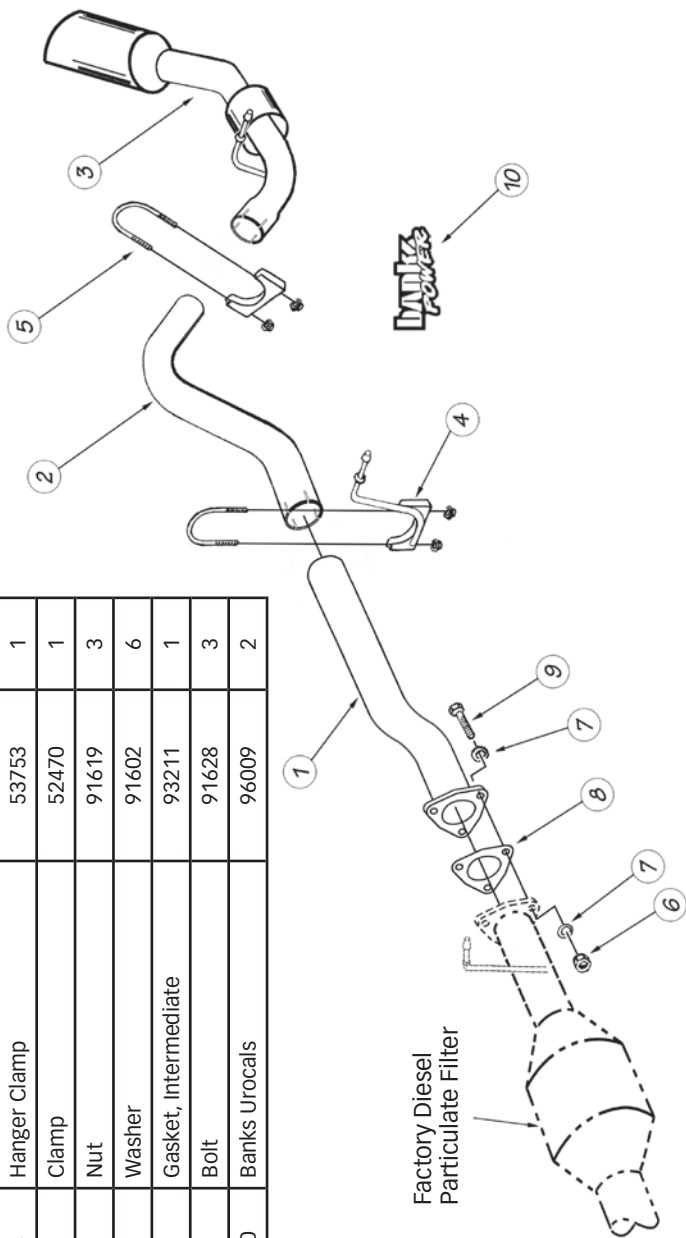

# Monster Exhaust System Installation

**1.** As a precaution, disconnect the ground of the battery (if there is more than one battery, disconnect both).

**2.** Raise the vehicle and support it with properly weight rated safety stands, ramps or a commercial hoist. Follow the manufacturer's safety precautions. Take care to balance the vehicle to prevent it from slipping or falling. When using ramps, be sure the front wheels are centered squarely on the topsides; place the transmission in park; set the parking brake and place blocks behind the rear wheels.

**CAUTION: DO NOT WORK UNDER ANY VEHICLE SUPPORTED ONLY BY A JACK. SEVERE INJURY MAY RESULT.**

**WARNING! The following step may require the use of a torch and/or saw. Proper safety equipment should be used. Failure to use proper safety equipment may result in severe injury.**

**3.** Removal of the factory exhaust can be simplified by cutting the factory

exhaust pipe behind the muffler. This will allow the tailpipe to be removed as a separate piece.

**4.** Remove the factory tailpipe from the vehicle by disengaging the exhaust system hanger pins from the rubber hangers using a large screw-driver or pry bar.

*NOTE: Lubricating the rubber hangers with WD-40 or similar lubricant will ease removal of the hanger pins.*

**5.** Remove the factory muffler from the vehicle by removing the three (3) nuts from the factory exhaust flange located at the factory muffler inlet.

**6.** Install the Banks flanged intermediate pipe and 3-bolt gasket onto the headpipe. Loosely assemble with the supplied bolts, washers, and nuts.

**7.** Slide the supplied 4" exhaust hanger clamp onto the outlet of the Banks flanged intermediate pipe. Insert the hanger pin into the factory rubber hanger.

**Figure 2**

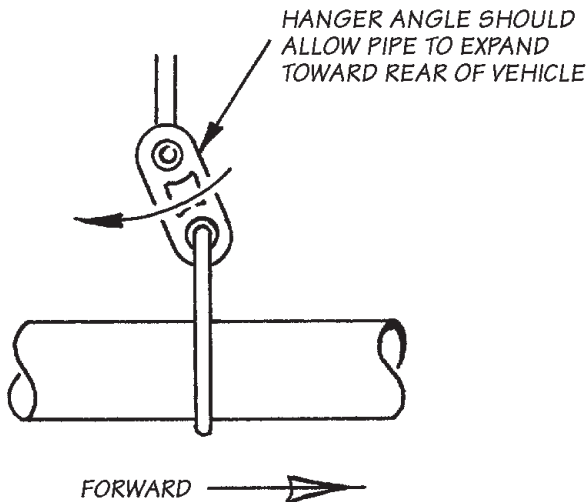

**Figure 3**

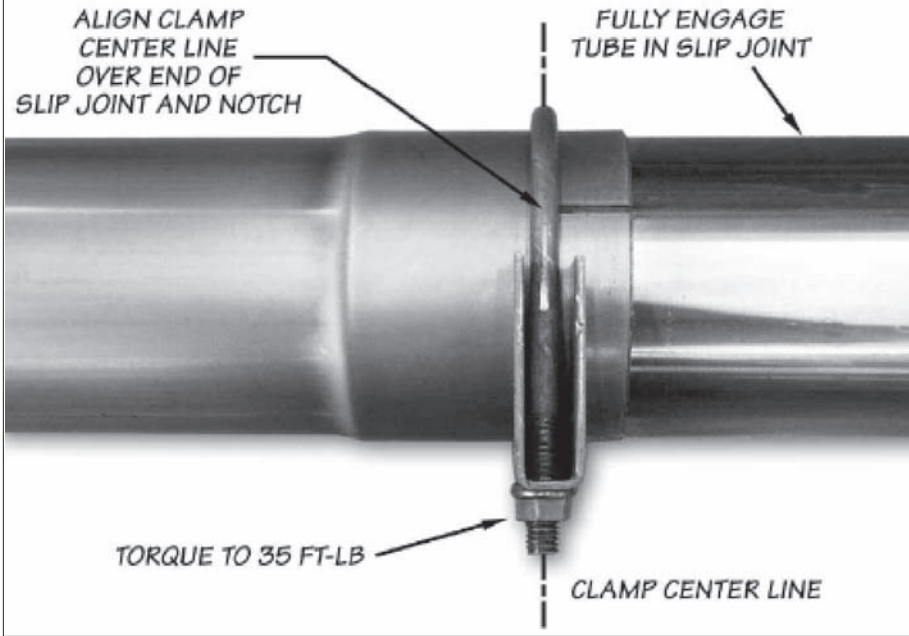

**8.** Route the Front Tailpipe over the rear axle housing and install onto the flanged intermediate pipe outlet. Be sure that the two pipes are completely engaged. Loosely snug the 4" hanger clamp.

**9.** Install a 4" exhaust clamp onto the inlet of the Rear Tailpipe. Install the Rear Tailpipe onto the outlet of the Front Tailpipe. Insert the Rear Tailpipe hanger pin into the factory rubber hanger. Rotate the tailpipe until the hanger pins are parallel with the frame mounted pin. Slide the 4" clamp and position as shown in **Figure 3**. Loosely snug the 4" clamp.

*NOTE: Maintain an adequate air gap clearance of one (1) inch between the exhaust and the shock absorber and between the exhaust and the spare tire.*

*NOTE: Minimum distance between exhaust tip and body is one (1) inch.*

**10.** Adjust each of the pipes to ensure that all of the hanger pins are parallel with the frame mounted pins and that the rubber hangers are all positioned slightly forward (See **Figure 2**). The amount of forward angle on the rubber hangers should increase the farther downstream the hanger is positioned. This allows the hangers to be properly positioned once the exhaust system reaches operating temperature.

**11.** **Figure 3** illustrates the proper location of an exhaust clamp on a tubing joint. Torque the nuts on each of the exhaust clamps to 35 ft-lb.

*NOTE: The clamps only need to be tight enough to form a seal and hold the pipes together. Over tightening the clamps may cause the system to leak due to the pipe being crimped.*

**12.** Remove the protective covering from the tailpipe tip.

**Caution: the protective covering may ignite and burn if not removed prior to running the engine.**

**13.** Your system includes two (2) Banks Power decals designed to complement the Duramax emblems on the vehicle's front doors.

**14.** Re-connect the negative battery cable. Start the engine and listen for exhaust leaks. Tighten the exhaust clamps as necessary. Whenever possible, tack weld slip connections to prevent disengagement is recommended. The Banks Monster Exhaust installation is now complete.

# 2007-2010 Chevy/GMC 6.6L Duramax Banks Monster Exhaust System

