

REVOLVERX2

HARD ROLLING COVER

REVOLVERX4

PREMIUM MATTE HARD ROLLING COVER

Installation Instructions

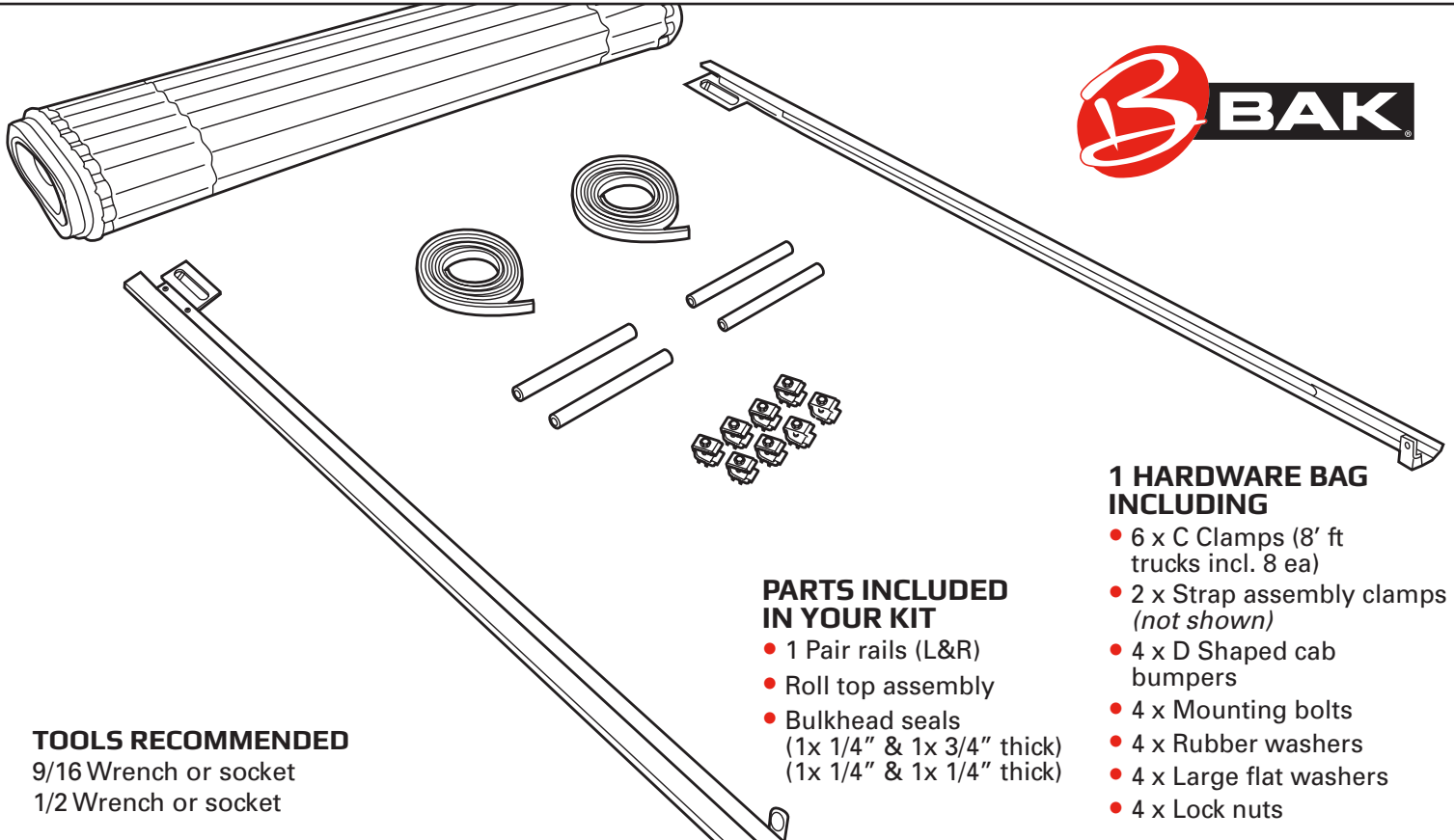

PARTS INCLUDED IN YOUR KIT

- 1 Pair rails (L&R)
- Roll top assembly
- Bulkhead seals (1x 1/4" & 1x 3/4" thick)
- Bulkhead seals (1x 1/4" & 1x 1/4" thick)

1 HARDWARE BAG INCLUDING

- 6 x C Clamps (8' ft trucks incl. 8 ea)
- 2 x Strap assembly clamps (not shown)
- 4 x D Shaped cab bumpers
- 4 x Mounting bolts
- 4 x Rubber washers
- 4 x Large flat washers
- 4 x Lock nuts

TOOLS RECOMMENDED

- 9/16 Wrench or socket
- 1/2 Wrench or socket

1

Install the bulkhead seal to the top of the bulkhead at the edge of the of the bed opening. If the truck **does NOT** have a drop in bedliner, use 3/4" seal. If the truck **does** have a drop in bedliner, use 1/4" seal.

2

FIG 2a

Position the rail with the silver slotted bracket all the way forward towards the cab of the vehicle. If the truck is equipped with a drop in bedliner remove the foam pad located on the slotted bracket as shown in Fig. 2a.

3

Position clamp as close to the end of rail as possible, should be less than 12" from the end. Make sure rail is clamped square as shown.

NOTE: Some drop in liners may require trimming in the corners to fit the rail in the opening.

4

Make sure the clamp is inserted all the way up into the rail and the clamp teeth engage the ribs along the inside of the rail squarely.

5



Apply downward pressure to the rail when tightening the clamp to ensure the rail sets flush and seals properly. A second set of hands may help.

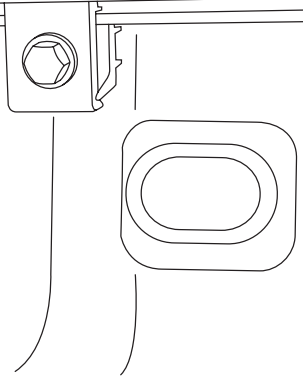

6

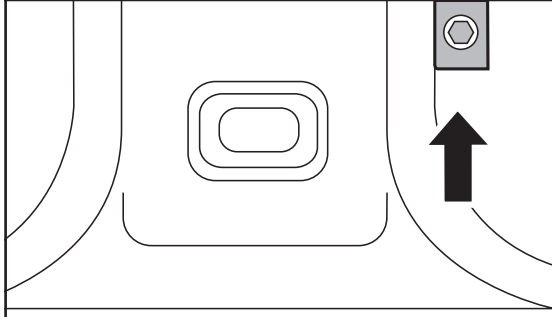

Place the 2nd clamp near the center of the rail. See steps 4 and 5 to ensure the clamp goes on correctly. (8' beds-evenly space 2 clamps between ends).

7

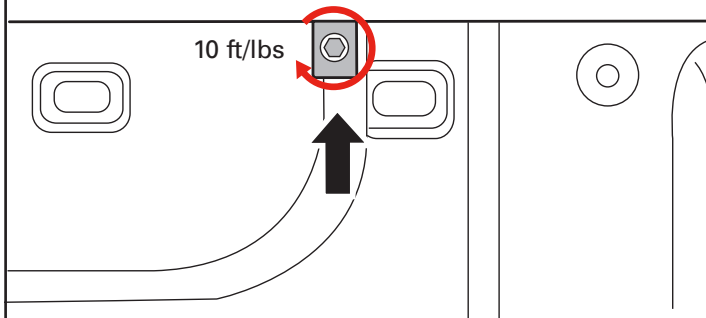

Place the rear clamp as close to the tailgate as possible, should be less than 12". Check all clamps are square and tight with approx 10 ft/lbs of torque. Caution: over tightening the clamp may warp the bed cap.

8

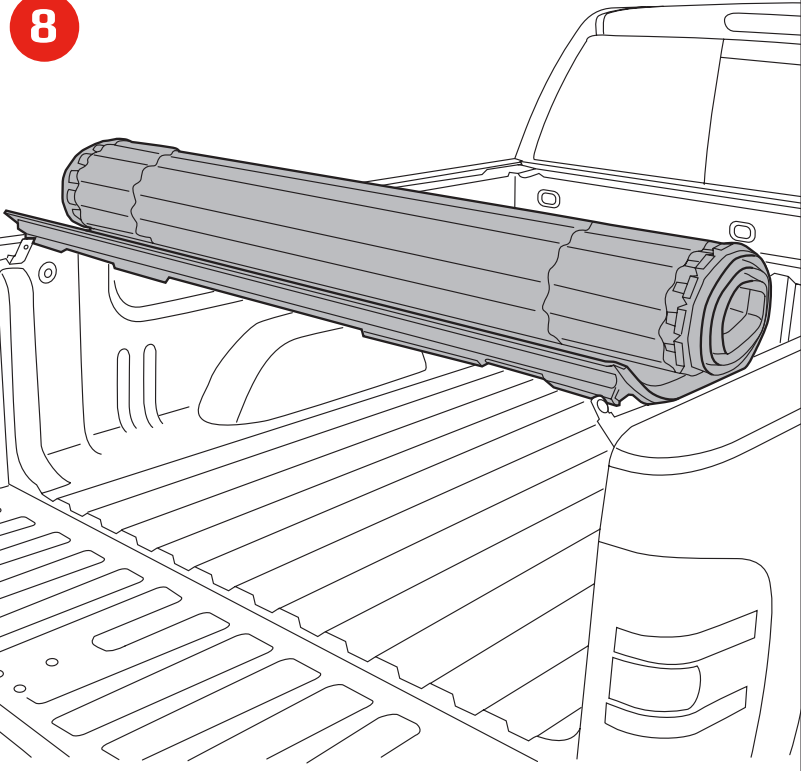

With both rails clamped in place, rest the roll top on the rails at the tailgate, roll forward into the opening and remove and discard all packaging materials.

9

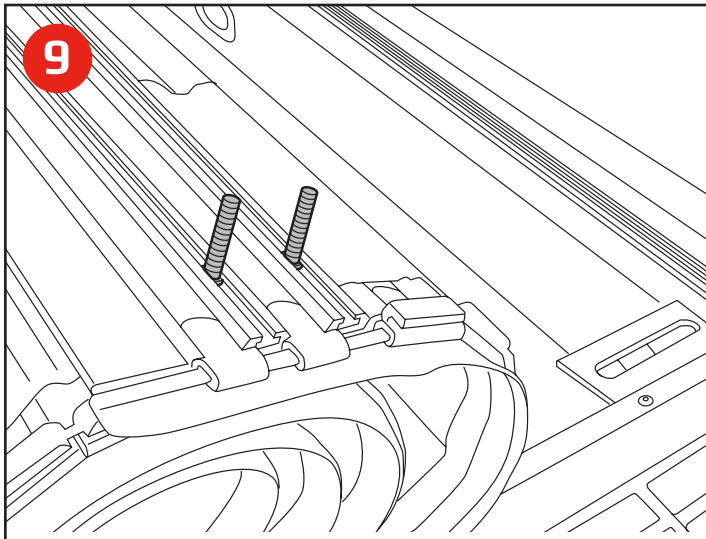

At the front cab, fold the cover back and insert 2 mounting bolts through the keyed slots. Repeat on opposite side.

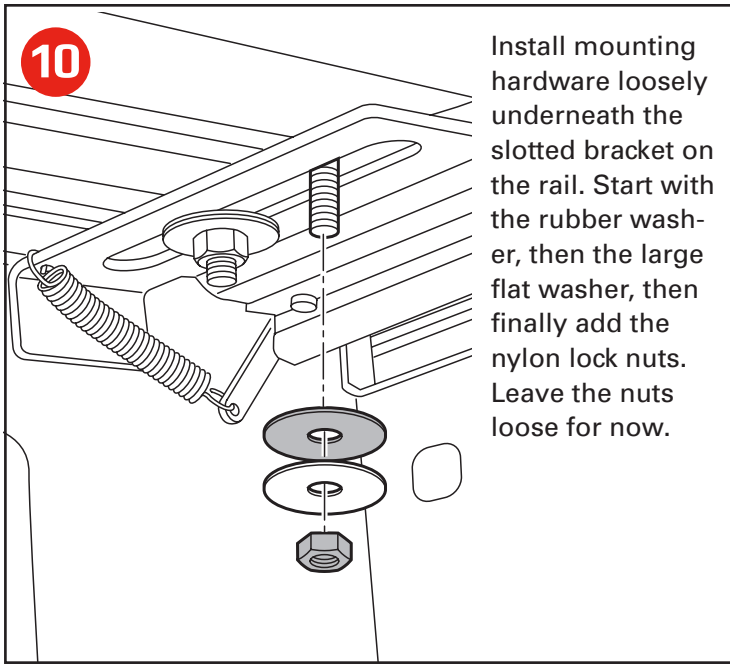

10

Install mounting hardware loosely underneath the slotted bracket on the rail. Start with the rubber washer, then the large flat washer, then finally add the nylon lock nuts. Leave the nuts loose for now.

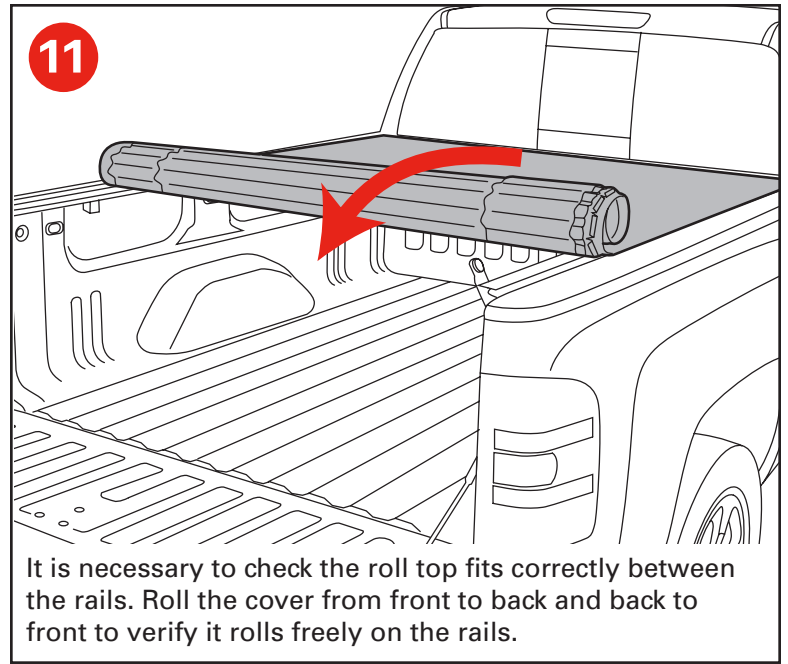

11

It is necessary to check the roll top fits correctly between the rails. Roll the cover from front to back and back to front to verify it rolls freely on the rails.

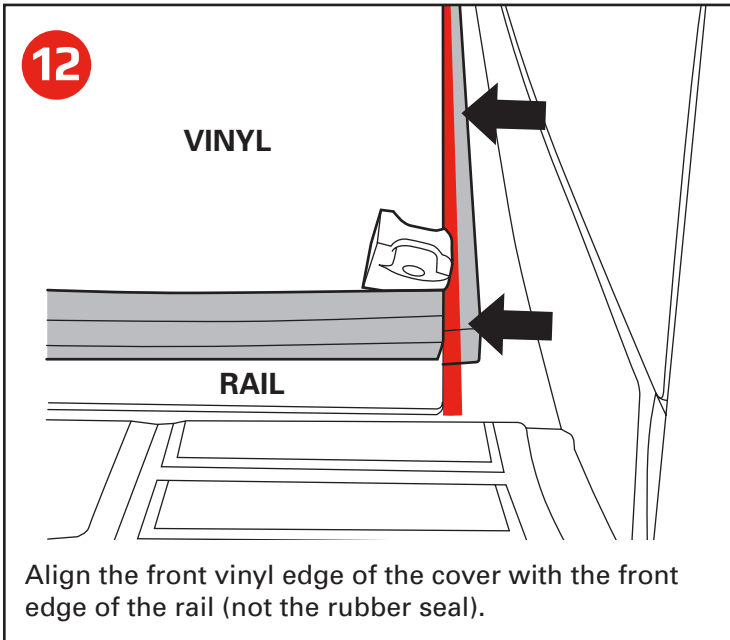

12

VINYL

RAIL

Align the front vinyl edge of the cover with the front edge of the rail (not the rubber seal).

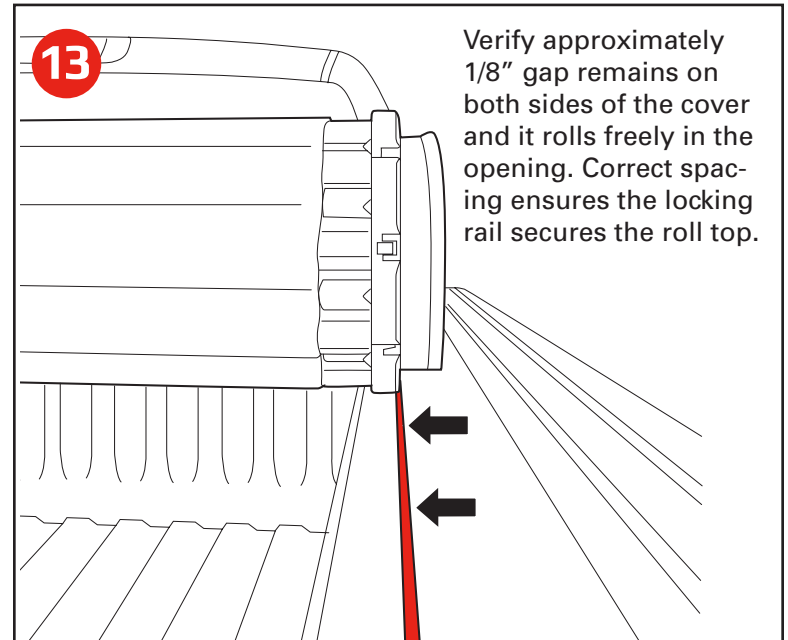

13

Verify approximately 1/8" gap remains on both sides of the cover and it rolls freely in the opening. Correct spacing ensures the locking rail secures the roll top.

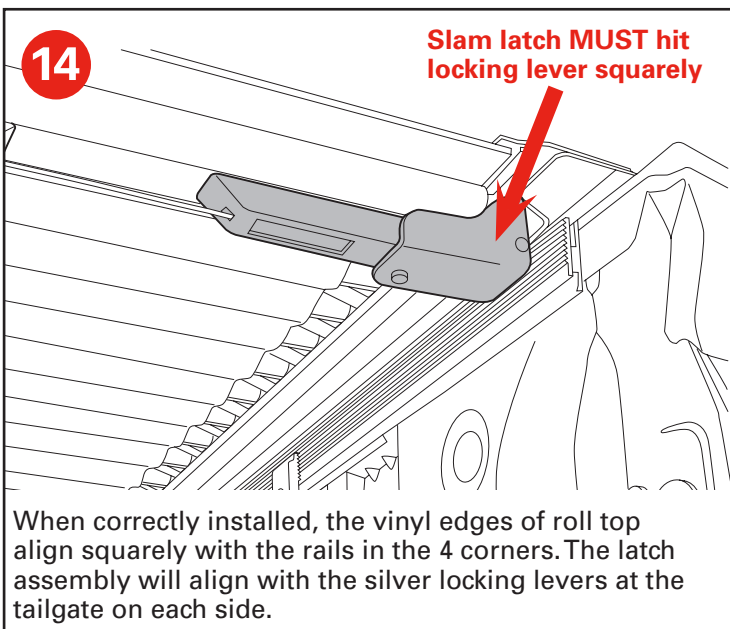

14

Slam latch **MUST** hit locking lever squarely

When correctly installed, the vinyl edges of roll top align squarely with the rails in the 4 corners. The latch assembly will align with the silver locking levers at the tailgate on each side.

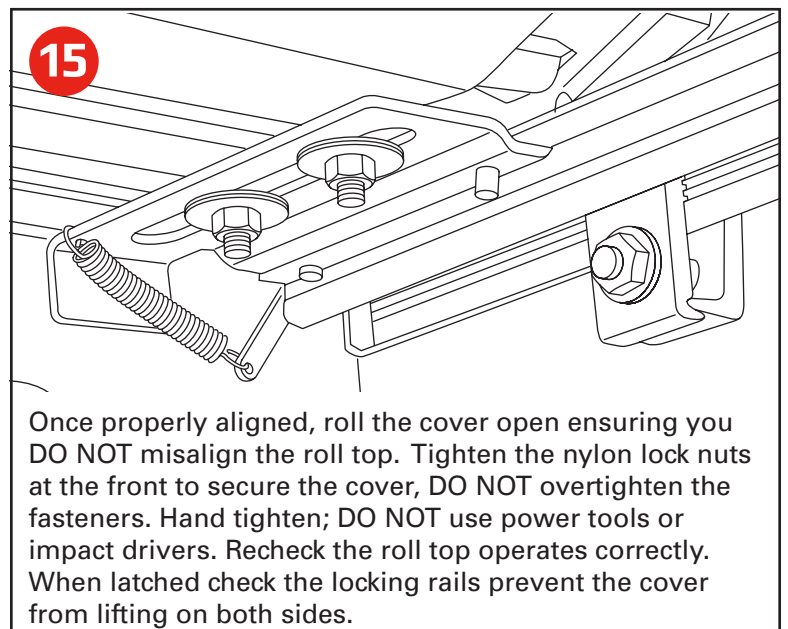

15

Once properly aligned, roll the cover open ensuring you **DO NOT** misalign the roll top. Tighten the nylon lock nuts at the front to secure the cover, **DO NOT** overtighten the fasteners. Hand tighten; **DO NOT** use power tools or impact drivers. Recheck the roll top operates correctly. When latched check the locking rails prevent the cover from lifting on both sides.

16

Check to see that the latches at the tailgate fully engage and make proper contact with side rails.

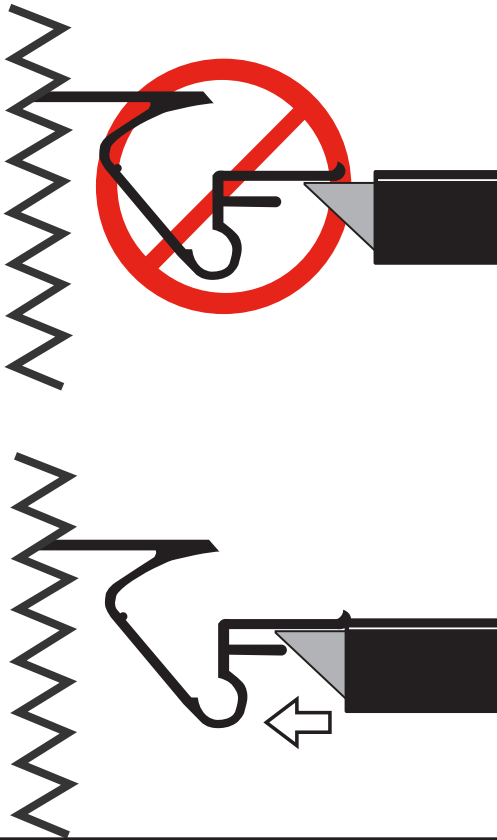

17

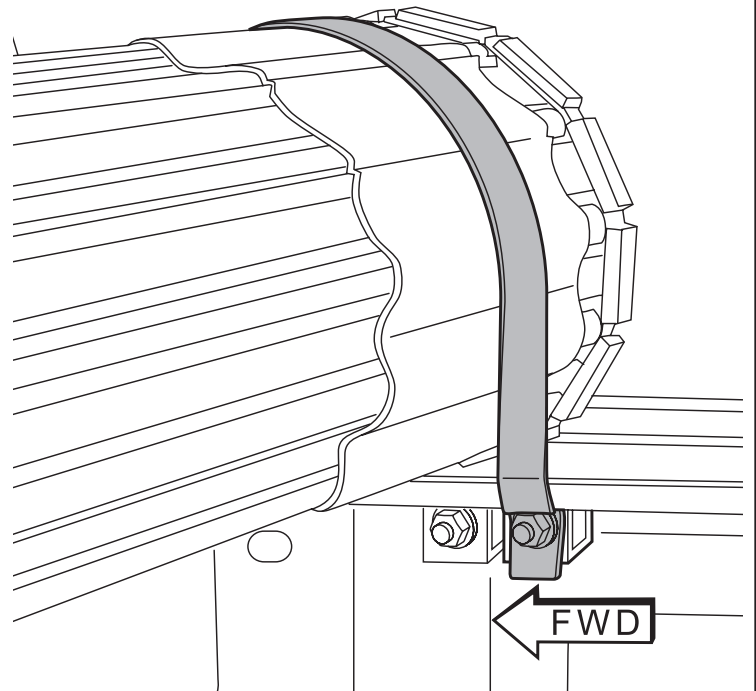

Mount the strap clamp assembly as far forward on the rail as possible and tighten. Repeat on opposite side.

18

! IMPORTANT

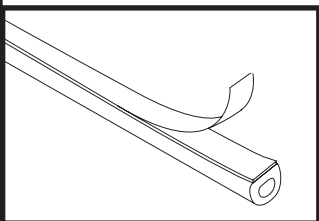
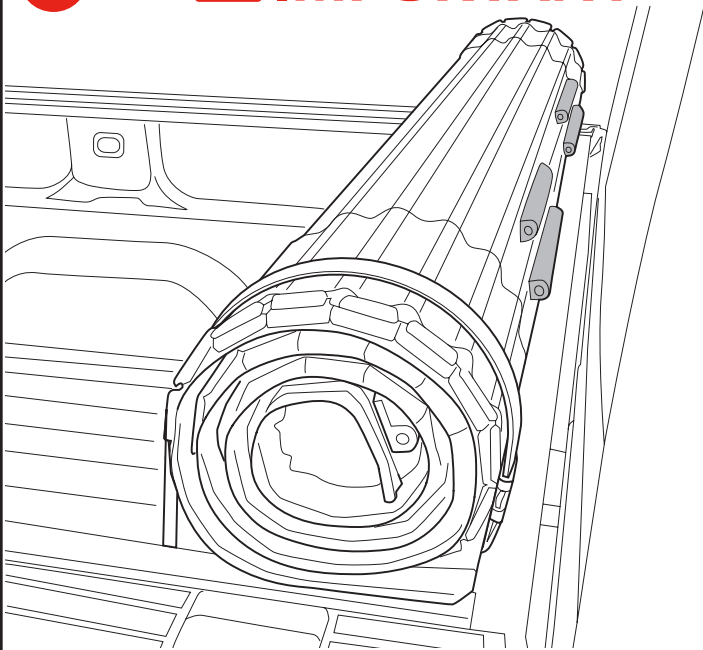

Roll the cover open and place the D shaped bumpers to the aluminum underside where they will prevent contact if the cover is rolled all the way open. The straps will hold the cover off the cab and glass when secured.

19

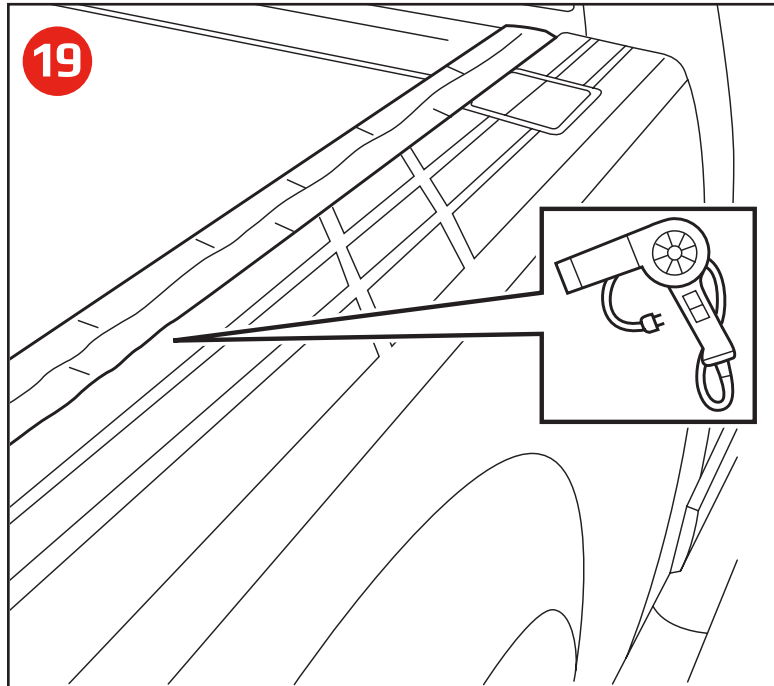

If the side seals of the cover appear wrinkled you may leave the truck in the sun to assist the seals to lay flat. To expedite, apply heat with a hair dryer or heat gun.

IMPORTANT Safe operation and use

IMPORTANT NOTICE

While driving, cover must be completely flat and secure with BOTH rear latches engaged and in the closed position OR completely rolled up and secured at the cab with the provided straps. **DO NOT DRIVE** with cover partially opened.

Tonneau Cover Positions While Operating Vehicle

Prior to vehicle operation, tonneau cover MUST be properly secured.

CLOSED POSITION (FIG 1)

Cover must be closed and **FULLY LATCHED ON BOTH SIDES** of the tonneau side rails.

OPEN POSITION (FIG 2)

To drive with your cover in the open position, simply make use of the provided tie down straps. Roll the cover forward and stop approximately 4" from the cab and insert the strap clips into the buckles at the end of the cover. Ensure BOTH strap clips are fully inserted and tighten the straps with the adjustment locks to ensure the cover doesn't roll or shift during vehicle operation.

Cover Operation

TO CLOSE THE COVER (FIG 3)

Roll the top towards the tailgate and rotate the tail rail downwards towards the rotating locking levers.

WARNING – When closing the cover ensure rear latches on BOTH sides are fully engaged underneath the rails before operating the vehicle.

TO OPEN THE COVER (FIG 4)

Pull downwards on latch release cable located on either side of the cover and rotate tail rail forward and into a rolling motion. Cover should be rolled into a bundle towards the cab of the vehicle and only driven with the cover secured with the provided straps.

DO NOT ATTEMPT TO DRIVE WITH THE COVER IN THE PARTIALLY OPEN POSITION!

ADDITIONAL IMPORTANT OPERATING TIPS

- Tonneau cover MUST be free of foreign material including snow and ice before opening rail top.
- Do NOT tow your vehicle from the rear with the tonneau on your truck.
- Do NOT operate vehicle with objects on top of cover.

FAILURE TO FOLLOW THESE CAUTIONS MAY RESULT IN SEVERE DAMAGE AND WILL VOID YOUR WARRANTY!



Remove any snow or foreign matter before rolling cover.



Do NOT tow your vehicle from the rear with this cover on your truck.

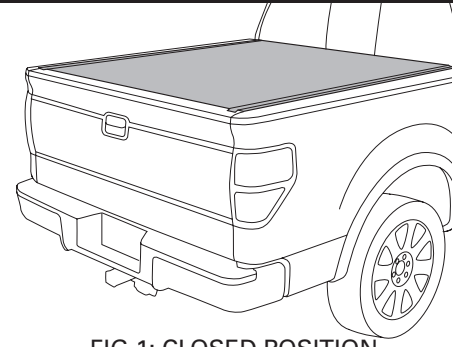

FIG 1: CLOSED POSITION

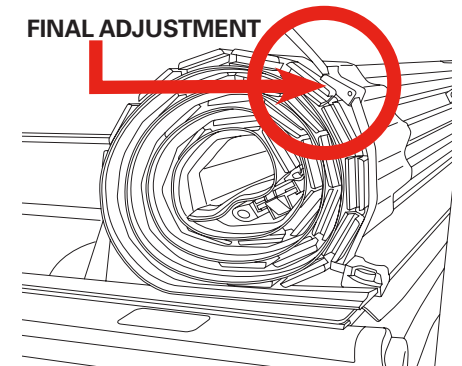

FIG 2: OPEN POSITION

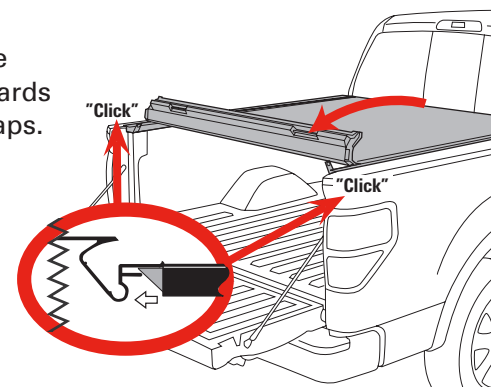

FIG 3: TO CLOSE THE COVER

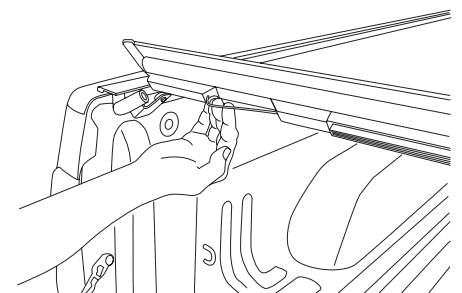

FIG 4: TO OPEN THE COVER