

**1** 6061-T6 CNC Machined /  
Type 3 Hard Anodize

**2** Pre-Load Device:  
· Stainless Steel  
· Durable Micro-Tex Coating



**4** All Stainless Steel Hardware

**3** Universal Mounting Bracket  
· Stainless Steel  
· Durable Micro-Tex Coating

**5** Lens Patterns and Material:  
· Wide Cornering [W.C.] (44°)  
· Driving Combo [D.C.] (6° Top, 44° Bottom)  
· Spot (6°)  
· Polycarbonate w/ Hard Coating

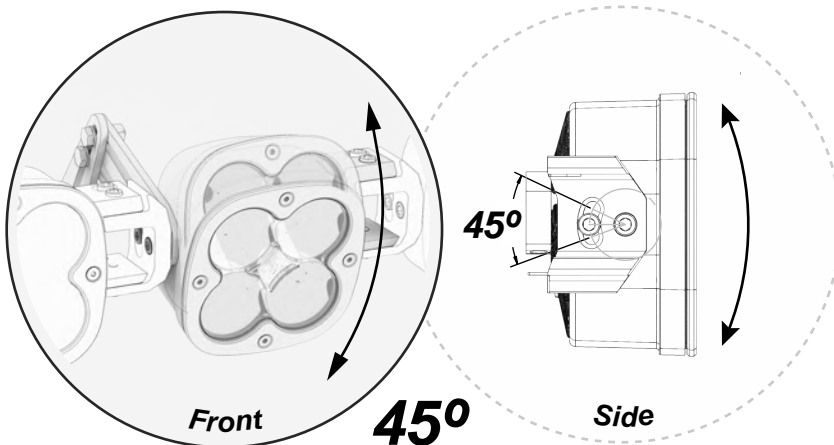

## Adjustment

! Some listed items are offered separately.  
Patent Pending

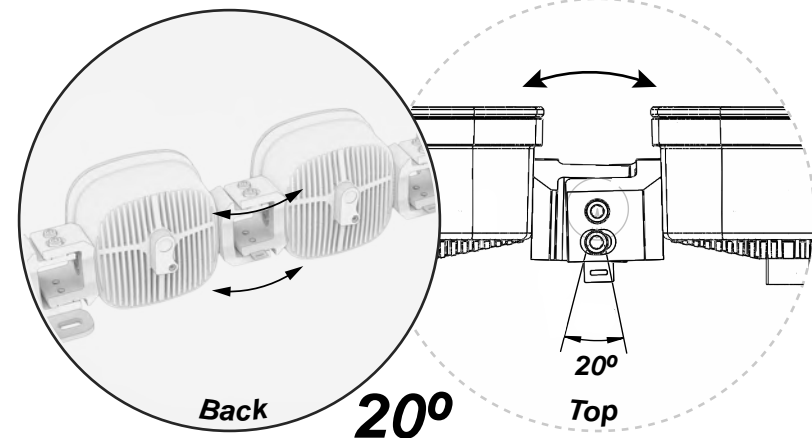

## Out of the Box

Perform the following on a flat table after receiving! - Do this before mounting.

Figure 1

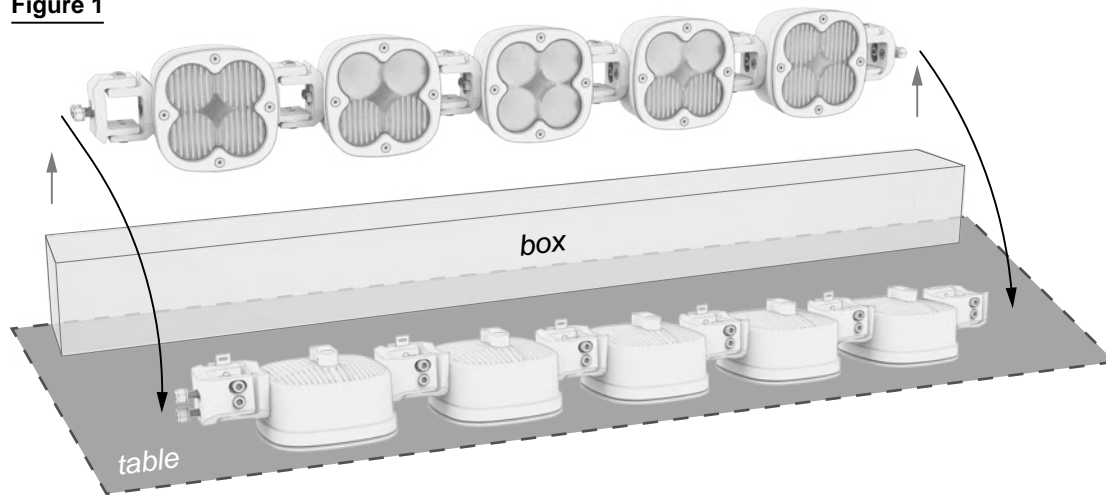
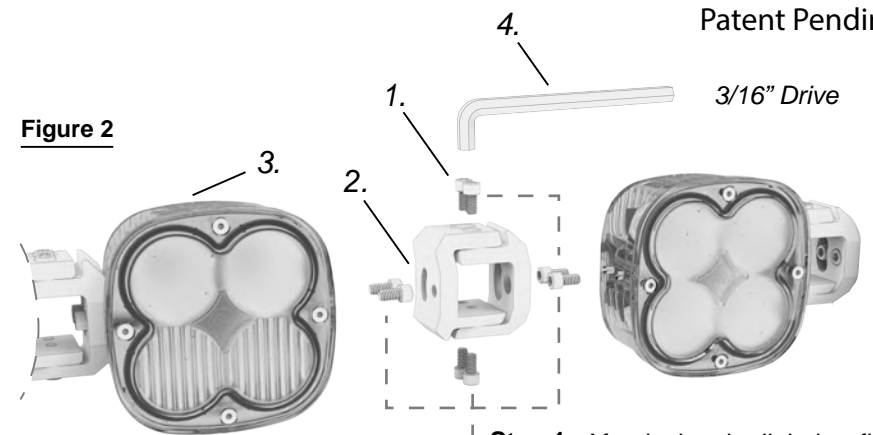

Figure 2



**Step 1.** After laying the light bar flat on a table, start from one side and adjust one axis at a time by loosening the indicated 1/4"-20 screws<sup>1</sup> on each link<sup>2</sup> to allow each light pod<sup>3</sup> to rest flat on the table. A 3/16" Allen Wrench<sup>4</sup> is included.

**Step 2.** With each light pod flat against the table, tighten all the 1/4"-20 screws

## Assembling Pre-Load Mechanism

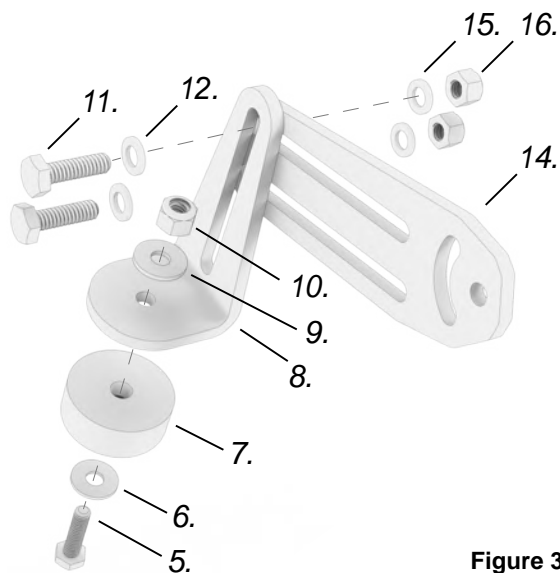

Figure 3

### Step 3. Required for (6-8) Lights

Using a 7/16" socket and wrench, assemble items (5 - 10). Refer to Figure 4 and Figure 6 (on next page) for the location and orientation of the Pre-Load Base<sup>14</sup> and Extension<sup>8</sup>.

- 5. 1/4"-20 x 1.00" Hex Head Bolt
- 6. 1/4" Oversized Washer
- 7. Rubber Bump Stop
- 8. Pre-Load Base Extension
- 9. 1/4" Oversized Washer
- 10. 1/4" Nylock Nut

**Step 4.** Then, assemble items (11 - 16) in the order shown in Figure 3.

- 11. 1/4"-20 x 7/8" Head Head Bolt
- (12, 15.) 1/4" Washer
- 14. Pre-Load Base
- 16. 1/4" Nylock Nut

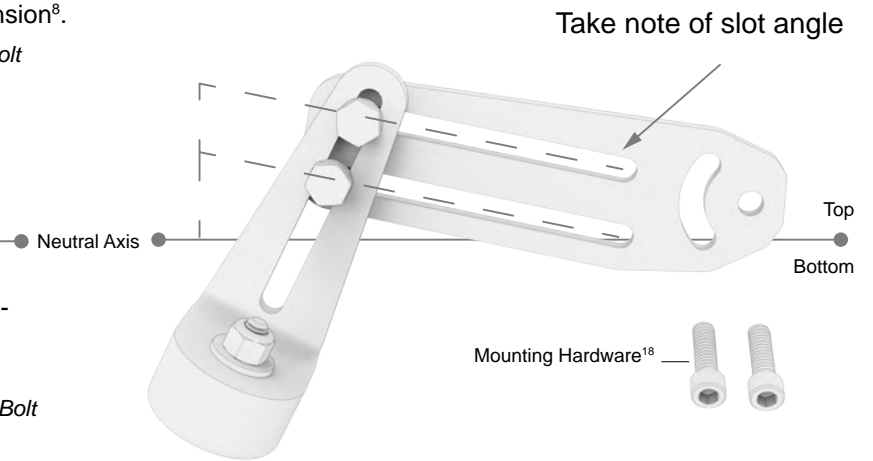
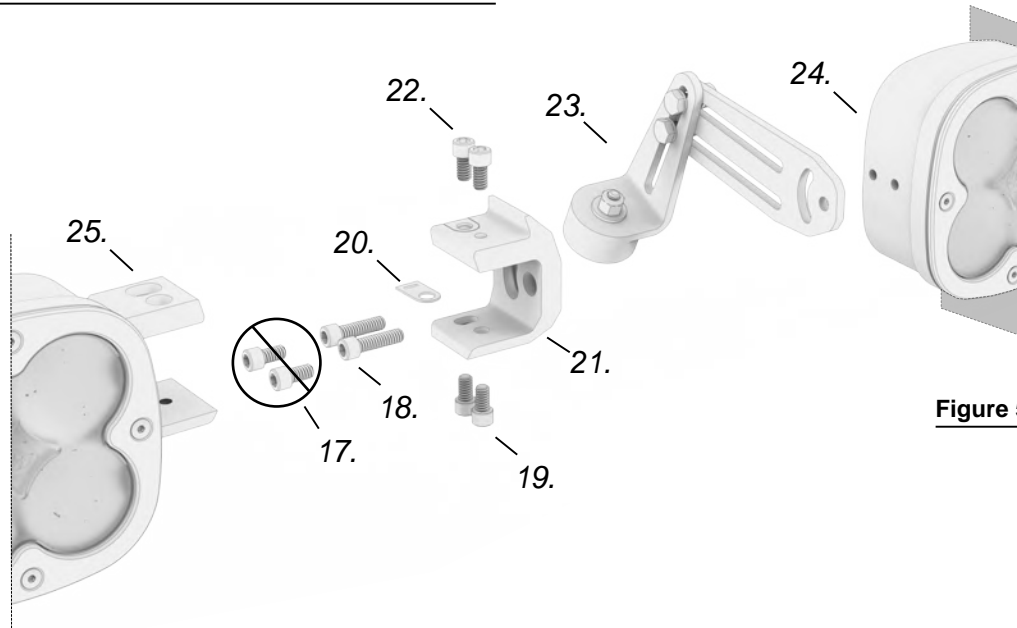

Figure 4

## Attaching Pre-Load Mechanism



**Figure 5**

**Step 5.** Refer to Figure 6 in order to locate which Socket Head Cap Screws<sup>(19, 22)</sup> to unscrew.

For the number of lights the XL Linkable has, locate that diagram in Figure 6. Unscrew the top and bottom Socket Head Cap Screws to the right of the Pre-Load Mechanism that secure the XL Links together. Separate as shown in Figure 5.

(17, 19, 22.) 1/4"-20 x 7/16" Socket Head Cap Screw

**Step 6.** Replace the 1/4"-20 x 7/16" Cap Screw<sup>17</sup> with the included 1/4"-20 x 7/8" Cap Screw<sup>18</sup>. Assemble items (18-25) in the order shown in Figure 5.

17. 1/4"-20 x 7/16" Socket Head Cap Screw

18. 1/4"-20 x 7/8" Socket Head Cap Screw

20. Zip Tie Tab (on harness)

(21, 25.) Link

23. Pre-Load Mechanism

24. XL Housing

## Positioning Pre-Load Mechanism

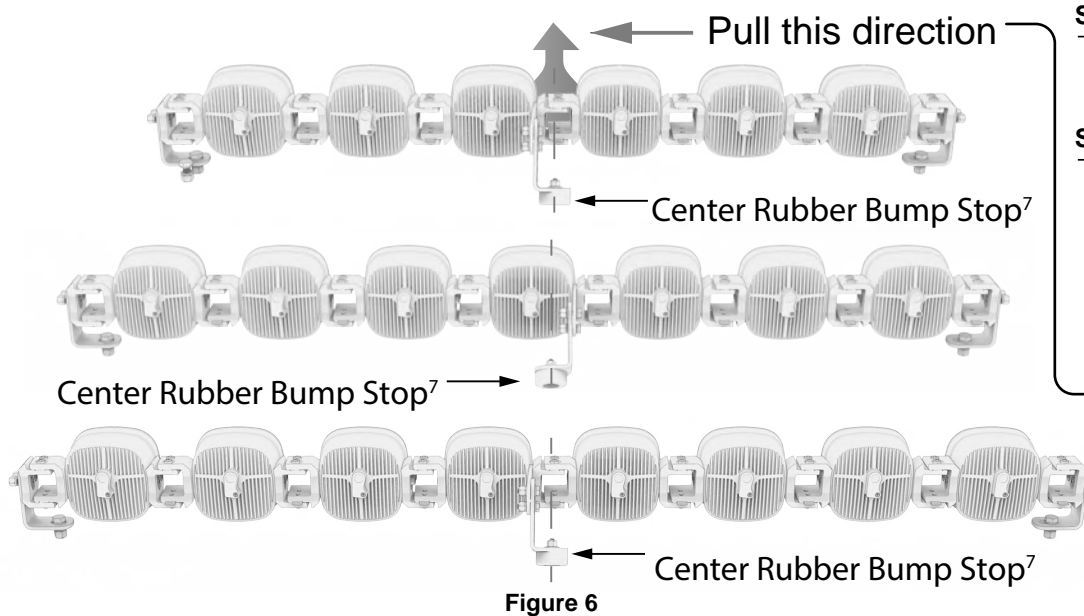

**Figure 6**

**Step 7.** Check to make sure the Rubber Bump Stop<sup>7</sup> is centered on the XL Linkable as shown in Figure 6.

**Step 8.** **The Pre-Load Mechanism is required for 6+ lights.** To reduce vibration and increase stiffness of the XL Linkable, add pre-load.

Make sure all Socket Head Cap Screws are tight. Using a 7/16" ratchet and wrench, loosen the 1/4"-20 x 7/8" Hardware<sup>11</sup> a quarter turn such that it can pivot.

Pull the XL Linkable away from the vehicle (indicated by shaded arrow in Figure 6), and then tighten the Hardware<sup>11</sup> with the Rubber Bump Stop<sup>7</sup> firmly resting on the included 3M<sup>®</sup> Clear Bra<sup>26</sup>, perpendicular (Figure 7), on a sturdy surface.

**Figure 7**

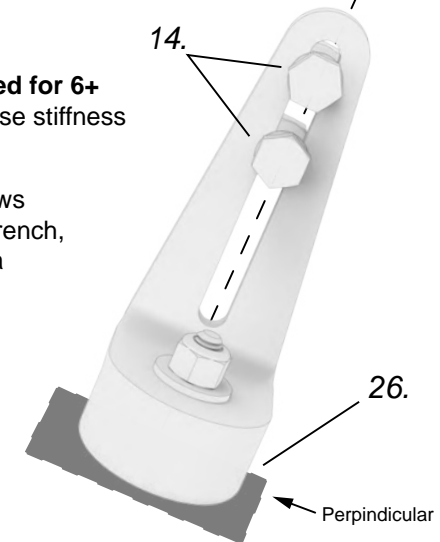

### Liability Disclaimer

The XL Linkable has been designed and tested around Baja Designs' vehicle specific mounting solutions, and under responsible driving conditions. Baja Designs releases liability on damage that can occur by using a third-party mounting solution. Baja Designs is not liable under any circumstance for damages or bodily harm due to irresponsible driving, improper application/mounting, and/or negligence of recommended maintenance.

- It is advised that installation be performed by a Baja Designs Authorized Dealer.
- Installation is recommended to be performed by at least two individuals in a safe work environment.
- The recommended number and location(s) of the Baja Designs Pre-Load Mechanism(s) must be installed for a specific vehicle.



## How to Mount

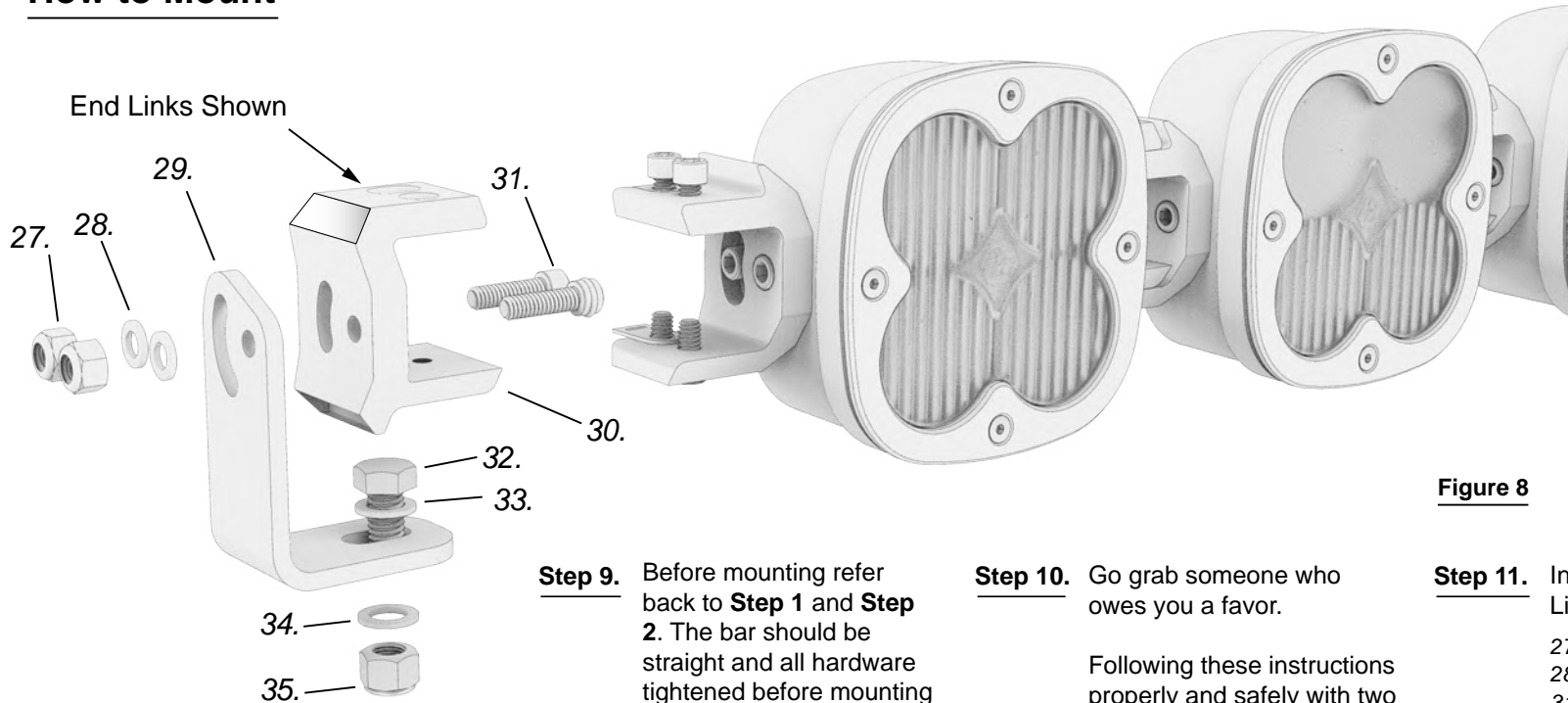

**Step 12.** Using the included hardware in the XL Linkable Universal Bracket Kit (available separately), orient the Hardware<sup>(32, 33, 34, 35)</sup> as shown in Figure 8.

Tighten the 3/8" hardware with a 9/16" ratchet and wrench.

Adjust the pitch of the entire XL Linkable and tighten in place.

32. 3/8" x 7/8" Hex Head Bolt  
 (33, 34.) 3/8" Washer  
 35. 3/8" Nylock Nut

**Figure 8**

**Step 9.** Before mounting refer back to **Step 1** and **Step 2**. The bar should be straight and all hardware tightened before mounting the XL Linkable to any brackets.

Confirm that the Pre-Load Mechanism<sup>23</sup> is installed properly. Refer to **Step 3** through **Step 8**.

**Step 10.** Go grab someone who owes you a favor.

Following these instructions properly and safely with two people will make for a properly aimed and adjusted light that you can shred 'dem trails and dunes with.

**Step 11.** Included in the parts bag for the XL Linkable are four of each:

- 27. 1/4" Nylock Nut
- 28. 1/4" Washer
- 31. 1/4"-20 x 7/8" Socket Head Cap Screw

Without removing any Hardware, secure the bracket (XL Universal Bracket<sup>29</sup> shown) using the two 1/4"-20 x 7/8" Socket Head Cap Screws<sup>31</sup> and 1/4" Nylock Nuts<sup>30</sup> on each side in orientation shown in Figure 8.

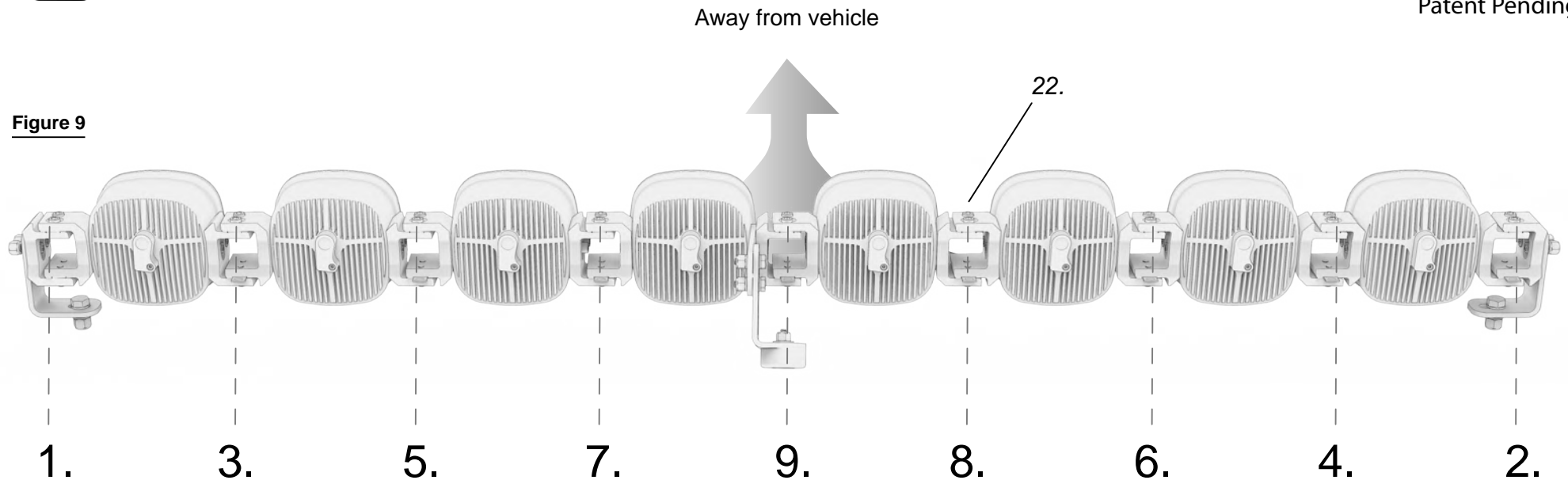
**Figure 9**

## How to Arc

**Step 13.** Start at the set of links indicated by the **number 1** in the diagram above. Barely loosen BUT DO NOT REMOVE the **top and bottom** 1/4"-20 x 7/16" Socket Head Cap Screws<sup>22</sup> using the included 3/16" Allen Wrench<sup>4</sup> or a Hex Bit.

Transition to the opposite side. In this case, loosen the top and bottom hardware at the set of links indicated by the **number 2**.

Loosen in pairs (i.e. 1&2, 3&4), and pull the XL Linkable away from the vehicle as shown in Figure 9 after loosening each pair of links until the desired arc and light spread are achieved.

**Step 14.** Tighten, in pairs and in the reverse order as done previously, making sure that each pair of links is tight before moving onto the next pair of links. Pull the XL Linkable away from the vehicle with steady force while tightening the Hardware<sup>22</sup>.

## How to Pitch

**Step 15.** Removing XL Links are not necessary to adjust the pitch.





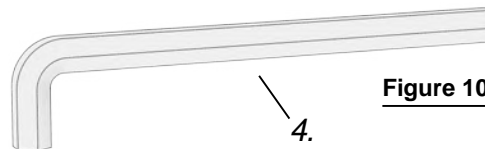
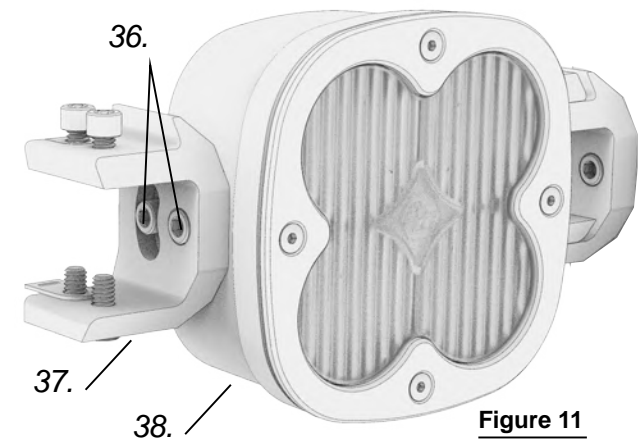

To individually pitch individual or sets of XL's, use the included 3/16" Drive Allen Wrench<sup>4</sup> to loosen the four outmost 1/4"-20 Socket Head Cap Screws<sup>36</sup> securing the XL Link<sup>37</sup> to the XL Light<sup>38</sup>.

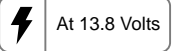
This will allow you pitch entire sections of the XL Linkable.

**Figure 10**

**Figure 11**

## General Dimensions



Lights	Lens Patterns	(Straight - Arced)	Power
<b>3</b>	 <p>D.C. SPOT D.C.</p>	<b>(20.77 - 20.82")</b>	<b>78W</b>
<b>4</b>	 <p>D.C. SPOT SPOT D.C.</p>	<b>(26.94 - 26.99")</b>	<b>104W</b>
<b>5</b>	 <p>W.C. D.C. SPOT D.C. W.C.</p>	<b>(33.14 - 33.16")</b>	<b>130W</b>
<b>6</b>	 <p>W.C. D.C. SPOT SPOT D.C. W.C.</p>	<b>(39.31 - 39.32")</b>	<b>156W</b>
<b>7</b>	 <p>W.C. D.C. SPOT SPOT SPOT D.C. W.C.</p>	<b>(45.49 - 45.47")</b>	<b>182W</b>
<b>8</b>	 <p>W.C. D.C. SPOT SPOT SPOT SPOT D.C. W.C.</p>	<b>(51.67 - 51.20")</b>	<b>208W</b>

## Performance Overview Diagrams

### Straight Versus Arced

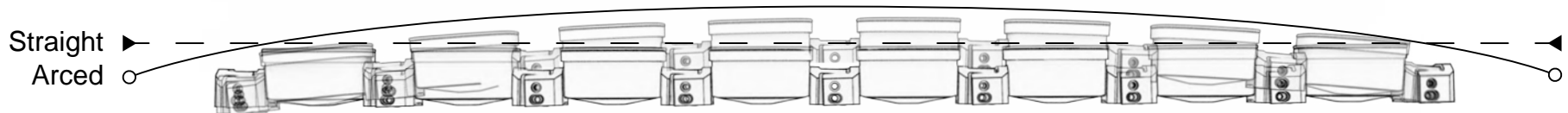

### Optical Heat Map 8 Lights

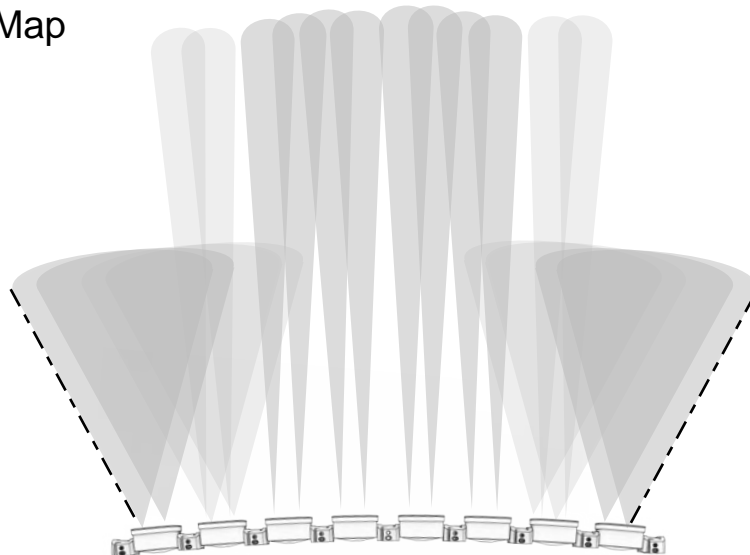

Straight  
44° Spread

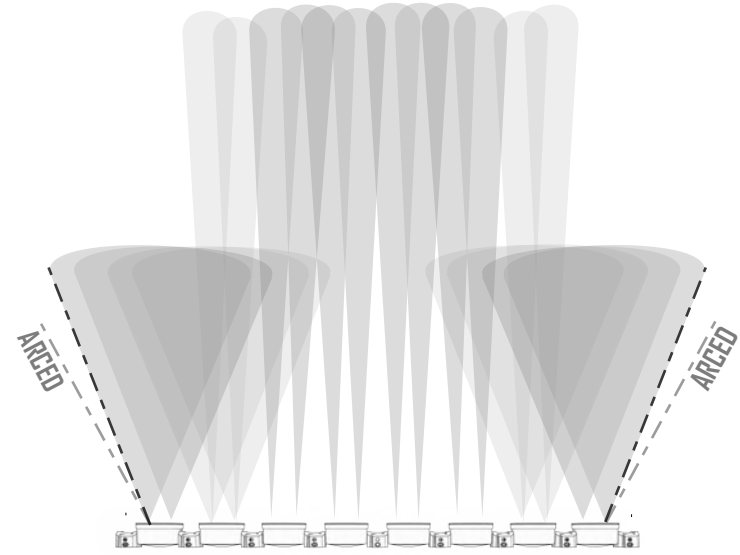

Arced  
64° Spread