



baja designs.
The Scientists of Lighting

1999-2010 Ford Super duty Fog Pocket Kit Instructions (63-0806)





baja designs.
The Scientists of Lighting

1999-2010 Ford, Super Duty Fog Pocket Kit Instructions

Special Note:

This kit works with three variants of the Super Duty series (99-04), (05-07), (08-10). The first instructions will cover the (99-04) and (05-07) models. The (08-10) instructions will follow.

1999-2007 Ford, Super Duty Fog Pocket Kit Instructions

Tools Required

- 10mm wrench
 - 10mm socket wrench
 - 7/16" wrench
 - 7/16" socket wrench
 - 8mm socket wrench
 - 13mm Socket wrench
 - 4mm Allen wrench
 - Phillip's head and standard screwdriver
1. To begin, open the hood and remove the four Phillip's head screws at the top of the grille (circled below). Support the grille from tipping forward. Removal of the grille will provide easy access to the top two bolts of each fog light assembly.

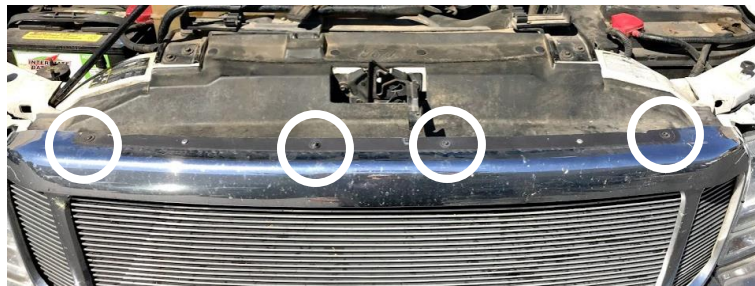

2. With a standard screwdriver (flathead), pry up on the four clips that hold the bottom of the grille on the vehicle. To access the clips, place the standard screwdriver in between the top surface of the bumper and under the grille. The photo below shows the location of the clips. The next photo shows the clip.





3. Now that the top two fasteners of each OEM fog light assembly are exposed, the bottom bolt on each will need to be addressed. These bolts can be found underneath the vehicle on the backside of the front bumper. There is a small rubber flap that can be pushed away to access the bolts. If needed, use a standard screwdriver to pry up the plastic fasteners holding the flap to the bumper. Below is an image of the OEM fog light bracket for reference.

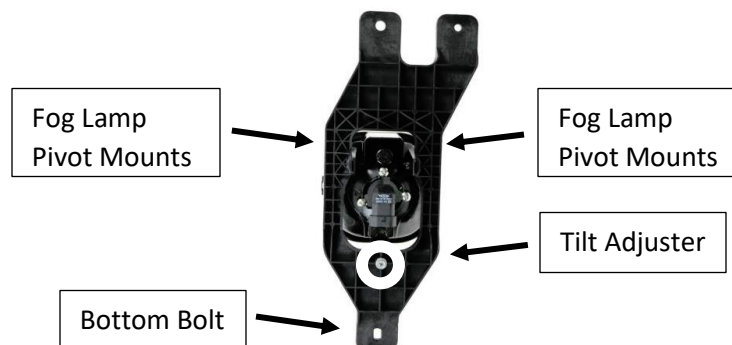

4. In order to remove the assembly from the bumper, the light will have to be removed from the bracket first. Using an 8mm socket wrench, remove the bolts from step 3. While still inside the bumper, the fog light assembly will have to be flipped around to expose the backside of the light. Using an 8mm wrench (or Phillip's head), remove the tilt adjuster bolt, spring, and plastic retaining nut. With the standard screwdriver, pry the fog lamp pivot mount plastic fasteners from the assembly to detach fog lamp. The now disassembled fog light can be removed from the bumper in two pieces. Repeat each step for the other assembly.



baja designs.
The Scientists of Lighting

5. Set the OEM fog lamps aside and keep the plastic OEM brackets for the new assemblies. Locate the stainless-steel Super duty brackets and the Squadron parts bags. With the 4mm Allen wrench, screw in the Squadron 6mm housing bolts through the washer, bracket, serrated washer, and then into the light housing. Repeat for the opposite side of the housing, then repeat for the other light. The exploded view below is for reference.

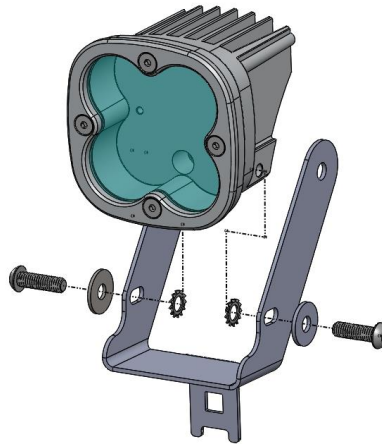

Special Note:

The two following photos have an enlarged bezel that is only for (11-16), which is not used for this kit.

6. Now it is time to mount the new light and bracket to the OEM plastic fog bracket. Using the 7/16" wrench and socket wrench, thread the 7/16" hex head bolt into the washer, plastic bracket pivot mount, steel bracket, washer, and nylon locking nut. Repeat for the adjacent fastener.

Note: the steel bracket goes on the inside of the OEM plastic bracket pivot mounts.





baja designs.
The Scientists of Lighting

7. Reuse the OEM fog lamp bracket tilt adjustment hardware with the new bracket circled below.

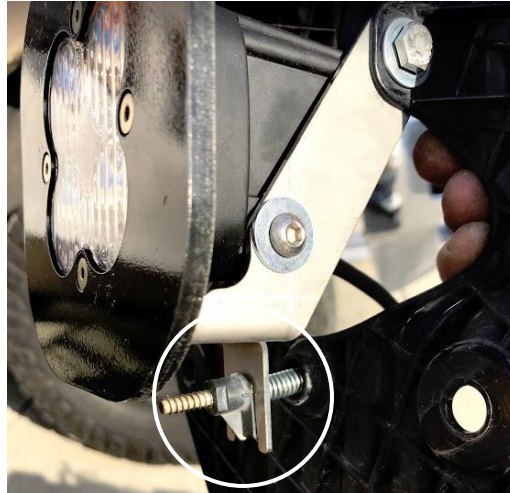

8. Adjust the housing bolts and OEM tilt adjuster until the desired fitment is attained.
9. Repeat steps 6-8 for the opposite side of the vehicle.
10. The new complete fog light assemblies will fit through the bumper for installation. The pictures below show the orientation that allows the new completed assemblies to fit through the opening. Install the new fog lamp assemblies and brackets with the 8mm socket wrench and fasteners from step 3. Tighten.



11. Attach the plug 'n play adapter to the factory harness and the Squadron power cord. Repeat this step for the other side. Tie the wires away from any hot and/or rotating components.



baja designs.
The Scientists of Lighting

12. To re-install the grille, move it into position and push the bottom of the grille to snap the clips back into place. With the Philip's head screwdriver, replace the four screws at the top of the grille and tighten.

2008-2010 Ford, Super Duty Fog Pocket Kit Instructions

Tools Required

- 7/16" wrench
 - 7/16" socket wrench
 - 4mm Allen wrench
 - 8mm socket wrench
 - 13mm Socket wrench
1. To begin, locate the bracket at the front of the passenger side wheel well pictured below. With the 13mm socket wrench, remove the three bolts. Place the bracket aside. Repeat steps for the driver's side.





baja designs.
The Scientists of Lighting

2. Unplug the OEM fog light connector from the OEM harness. With the 8mm socket wrench, remove the three bolts holding on the fog light assembly circled below. Carefully remove the assembly from the vehicle. Repeat step for the driver's side.



3. Locate the stainless-steel Super Duty brackets and the Squadron parts bags. With the 4mm Allen wrench, screw in the Squadron 6mm housing bolts through the washer, bracket, serrated washer, and then into the light housing. Repeat step for the opposite side of the housing, then repeat for the other light. The exploded view below is for reference.

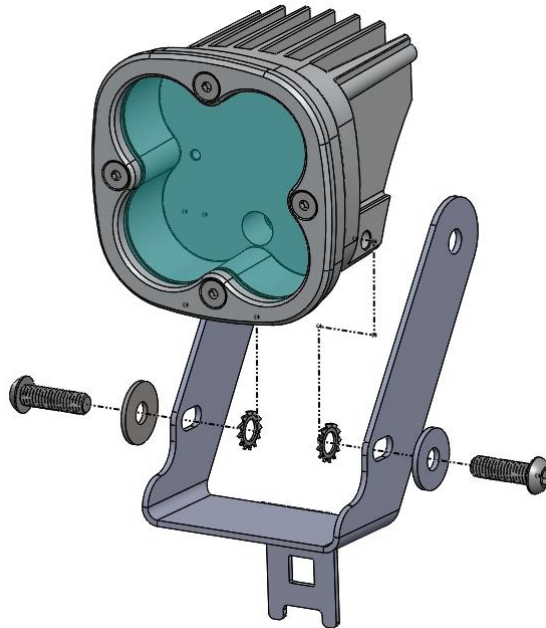



Special Note:

The two photos on this page have an enlarged bezel that is only for (11-16), which is not used for this kit.

4. Now it is time to mount the new light and bracket to the OEM plastic fog bracket. Using the 7/16" wrench and socket wrench, thread the 7/16" hex head bolt into the washer, plastic bracket pivot mount, steel bracket, washer, and nylon locking nut. Repeat for the adjacent fastener.

Note: the steel bracket goes on the inside of the OEM plastic bracket pivot mounts.



5. Reuse the OEM fog lamp bracket tilt adjustment hardware with the new bracket circled below.

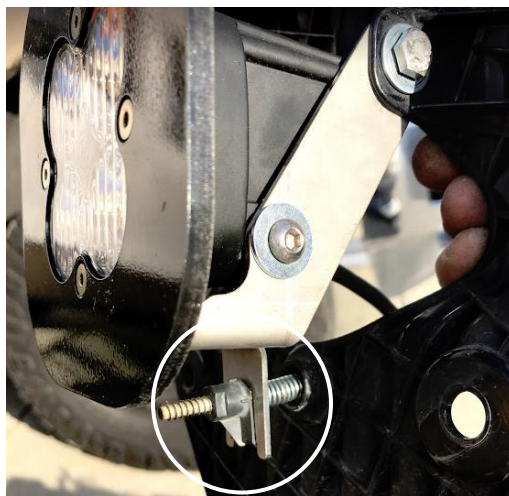



6. Adjust the housing bolts and OEM tilt adjuster until desired fitment is attained.
7. Repeat steps 4-6 for the opposite side of the vehicle.
8. Install the new fog lamp assemblies and brackets with the 8mm socket wrench and fasteners from step 2.
9. Attach the plug 'n play adapter to the vehicle's factory harness and the Squadron power cord. Repeat step for the other side. Tie the wires away from any hot and/or rotating components.
10. Re-install the brackets from step 1 with the 13mm socket wrench.

Re-torque all the fasteners after 100 miles.

Your install is now complete! Thank you for choosing Baja Designs.