



baja designs[®]
THE SCIENTISTS OF LIGHTING

Ford F150 (21+) Dual Squadron Fog Light Kit Instructions



Ford F150 Fog Light Instructions

Tools Required

- 9/16" Wrench and Socket
- 10mm and 1/2" Wrench (Battery tools)
- 4mm Allen Wrench
- Pliers
- T30 Torx bit
- 3/4 Drill (non-upfitter models)
- 21mm, 13mm, 10mm, 8mm and 7mm Socket wrenches
- Trim tool, or Flathead screwdriver
- Masking tape

1. To begin, place the vehicle in park, turn off and disconnect the negative battery terminal (1/2" wrench).
2. With the 7mm socket wrench, remove the two circled fasteners on the inside of the driver side wheel well holding on the lower grill trim. Repeat for the other side. Carefully pull the trim piece away from the wheel well to unclasp and then repeat for the other side.

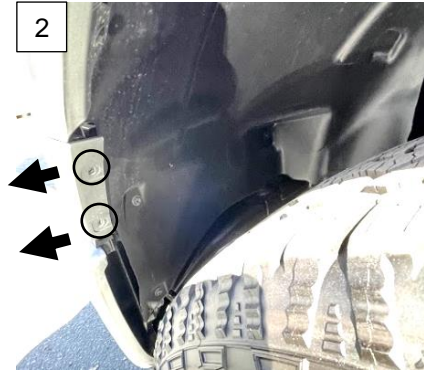

3. Once both sides are free, gently pull on the front of the grill trim piece away from the vehicle until it releases from the clips. Place aside. With the 8mm socket wrench, remove the two arrowed bolts that are on the bottom corners of the grill.



4. Open the hood. With the flathead screwdriver, or trim tool, remove the 12 arrowed plastic fasteners from the plastic radiator cover and place the cover aside.

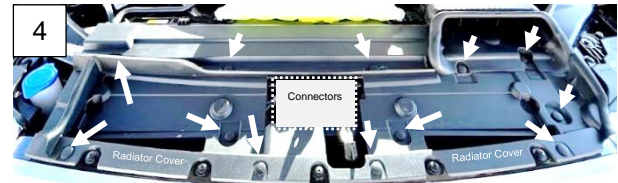

5. Depress the tab on the shutter body connector and disconnect. Repeat for the forward-facing camera (if equipped). Using a flathead screwdriver, or trim tool, pry the clip on the windshield wiper fluid hose (if equipped) fitting until it can pull out. Then pry up the harness clip attached to the top of the shutter housing. Place the wires toward the engine and free of the grill.



6. With the 10mm socket, remove the four circled upper grill bolts. Carefully pull the grill away from the truck and place onto a soft surface.



7. Directly under where the grill was mounted, there is a wiring harness along the top of the lower air dam. With the flathead screwdriver, or trim tool, remove the circled harness clips. Above the passenger frame rail, there is a large bumper connector that will need to be removed.



- Depress the tab on the light gray latch on the bumper connector and pull it toward the driver side to disconnect the bumper connector. Depress the tab on the lower dam shutter body connector (second image) and disconnect. Place the bumper harness over towards the front of the vehicle.

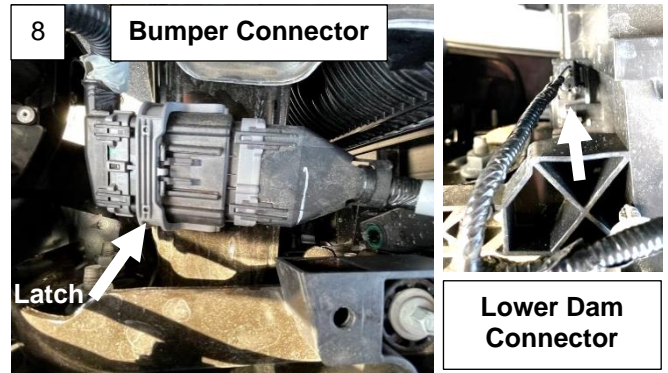

- With the 21mm socket wrench, remove the three circled bumper mounting nuts shown on the backside of the bumper on the passenger side. Have an assistant support the passenger side of the bumper and remove the remaining three bumper mounting bolts on the driver side. Carefully remove the bumper and place it face down on a soft work surface.

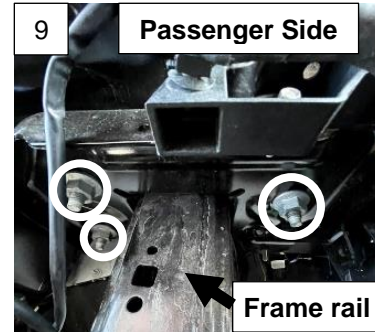

- Disconnect the connectors on each end of the dynamic lower valence assembly by depressing the tabs until each connector can be removed. The passenger side connector has a red locking tab that will need to be unlocked before it can be removed. Remove any harness clips that attach the wiring to the lower valence assembly.



- With the 10mm socket, remove the three circled valence actuator mounting bolts on the driver side as shown. Repeat for the passenger side. Carefully place the valence assembly aside making sure to remove any wiring harness clips that may still be attached.

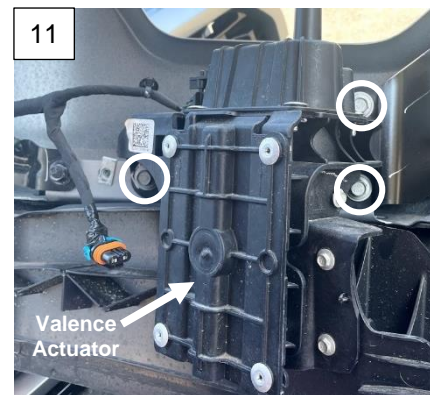

- Disconnect each fog light harness connector. With the T30 Torx bit, remove the four arrowed mounting bolts on each OEM fog light and place the lights aside. The driver side OEM fog light is shown.

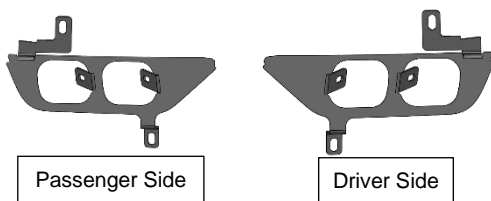

- Mount two of the squadron standard mounting brackets to the Baja Designs F150 fog light bracket (driver side shown) using the provided 3/8" hardware with the 9/16" wrench and socket. Note the orientation of the Squadron brackets in the image. Align the brackets perpendicular across each mounting bracket flange.

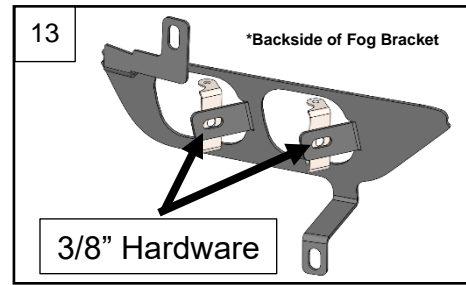

- With the provided Squadron hardware and 4mm Allen wrench, mount one light onto the Squadron bracket from the front of the Baja Designs F150 fog light bracket. Reference the exploded view on the right. The serrated washers install in between the light housing and the Squadron bracket. Masking tape can be used to prevent scratches to the light housing. Repeat for the three remaining lights.

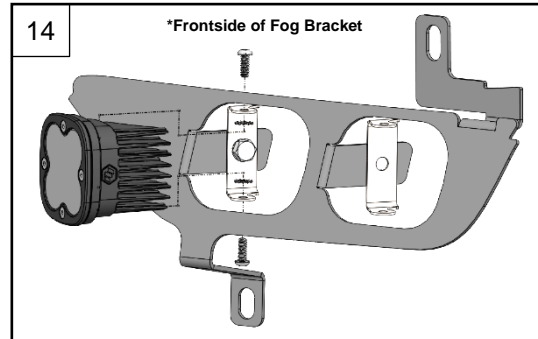

- Replace the lower valence assembly from steps 10-11 with the 10mm socket and reconnect the connectors (lock the passenger side connector). Leave the lower circled bolt off the lower valence assembly for a moment. Remount all the harness clips. With the 13mm socket, remove the circled upper bolt shown on the driver side shown on the right. Mount the driver side Baja Designs Squadron fog light assembly on the upper circled location and hand thread in the bolt. Thread in the bolt into the lower circled location and tighten with the 10mm socket. Tighten the upper circled bolt.

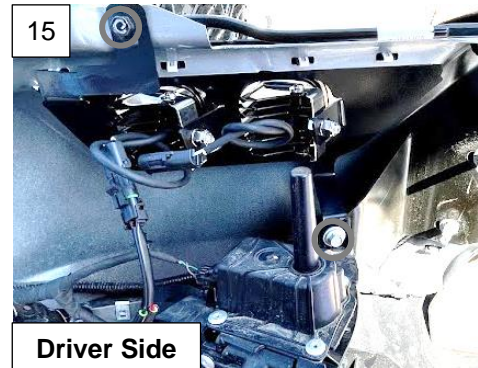

- Repeat for the passenger side.
- With an assistant, mount the bumper onto the vehicle and tighten the 13mm nuts from step 9. Reconnect all the harness connectors and clips from steps 7-8.

- Before replacing the grill, the lights will need to be wired.

- Attach the provided 2-Pin Anti-backfeed harness to the light intended to be switched with the OEM fog light switch. Connect the H10 in-line adapter to the same harness and plug into the OEM fog light connector (Red = Pin B, Black = Pin A). Repeat for opposite side. (Wiring diagram to the right)

- Route the large splitter to both sides with the main harness plug on the passenger side. Plug in the light connectors to the remaining open connectors in each fog light.

- Open the hood. Unravel the main harness and route the light lead of the harness down behind the passenger side headlight.

- Pull the plug from behind the front passenger side inner fender well and plug it into the large splitter.

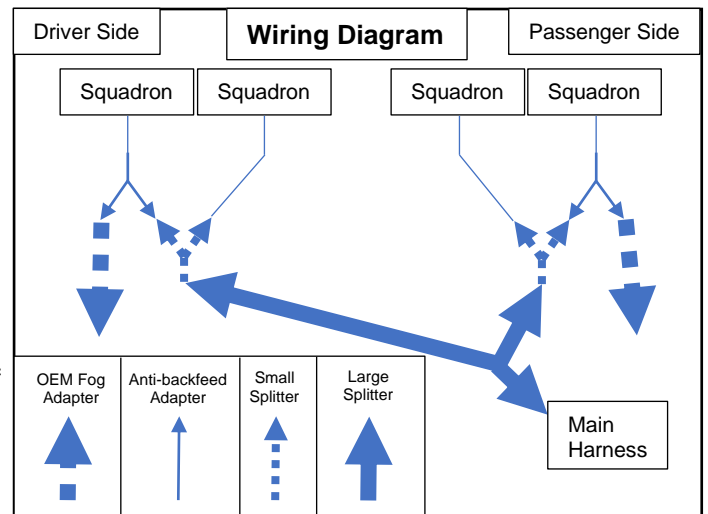

23. If you purchased the Upfitter switch version:

- Locate the bundle of upfitter wires on the passenger firewall taped to the harness passthrough closest to the motor (Right arrow). Do not use the bundle of wires that is furthest from the engine (Left arrow).
- Remove the tape to access the wires AUX 1,2,3,4, are Green/White, Brown/Blue, Gray/Yellow, and Green/Yellow, respectively. (Refer to owner's manual if colors vary)
- Using the pliers, clasp the splice connector on the upfitter splice harness over the desired wire/circuit. Wrap the tape back over the remaining wires. Make sure all wires are isolated and add electrical tape as needed.
- Mount the black ring terminal of the splice harness to the common ground on the inner passenger fender using a 10mm socket wrench.



24. If you purchased the stand-alone version:

- Locate the firewall passthrough grommet on the right side of the brake booster (Image for step 5). In the cab, this will be located to the right of the parking brake. Push grommet into engine compartment. Gently pull dash panel away until unclipped.
- Snap a photo of the switch wiring for reference later. Remove the switch terminals from the switch. Remove the tape around the wires on either side of the grommet.
- Locate a desired dash location for the switch and confirm that there is clearance behind. Drill 3/4" hole.
- Thread the wires through the hole in the passthrough grommet, mount switch, and reattach switch terminals. Tape around the wires of the grommet. Install dash panel.
- Mount the (+) and (-) ring terminals of the harness to the corresponding battery terminals starting with the (+) red lead.

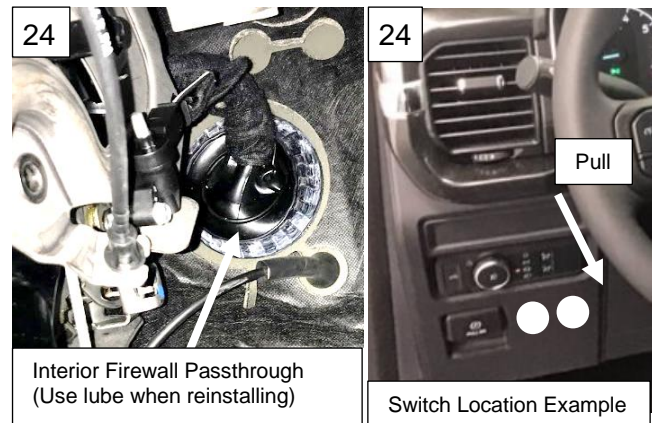
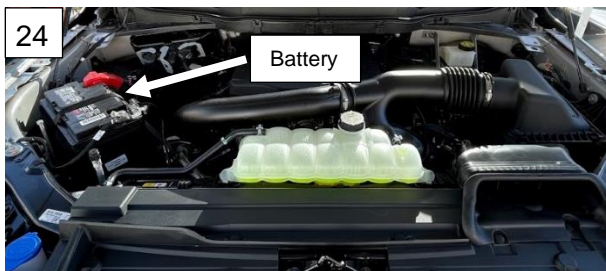

Tie all wires away from sharp, hot, and/or rotating components.

Re-torque all the fasteners after 100 miles.

Your install is now complete! Thank you for choosing Baja Designs.

Learn more about off-road lights we have.