

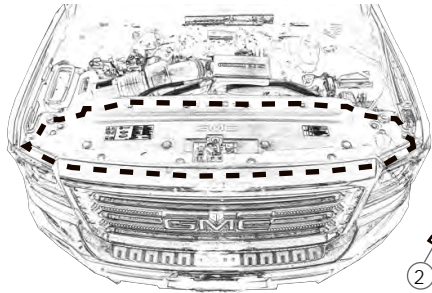

BEHIND THE GRILLE INSTALLATION

1. Put vehicle in Park. Disconnect battery. Remove 12 plastic clips shaded in the image (to the left). Insert a flatblade screwdriver, or clip removal tool at this location and gently pry upward. Lift up and remove the plastic shroud.



FRONT OF TRUCK

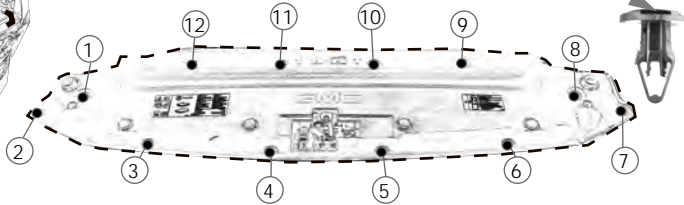

2. Use a 10mm socket and ratchet, remove 4 screws holding the grille in place.

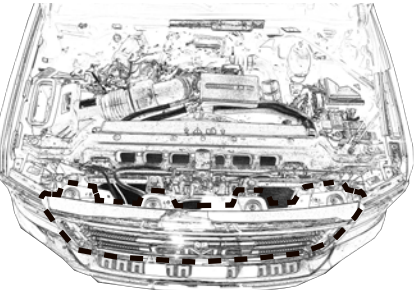

FRONT OF TRUCK

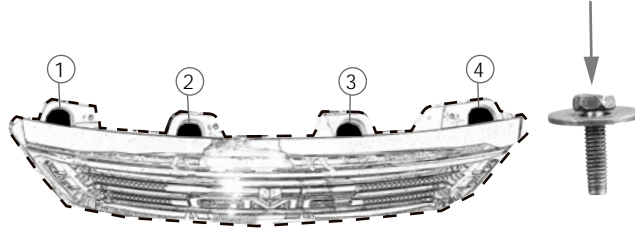

3. Apply constant force, outward, on the grille in the 10 shaded regions shown below to release the spring clips. Start from one side and work across the vehicle.

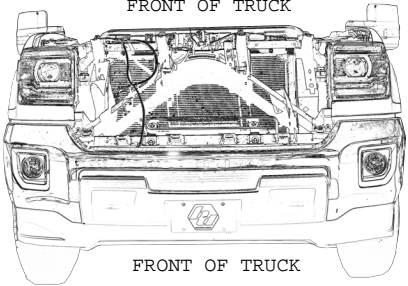

FRONT OF TRUCK

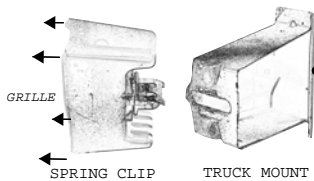
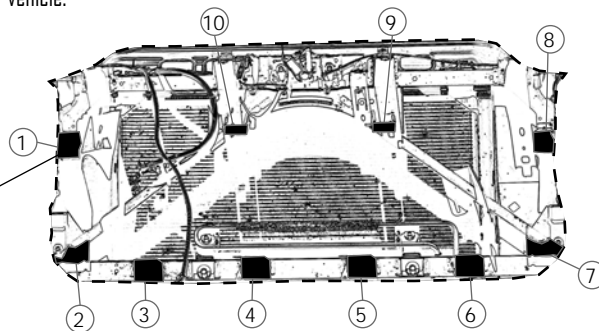

GRILLE
SPRING CLIP
TRUCK MOUNT

4. Locate the oil cooler fins in the shaded region. Gently push down on the fins until the cross-section below is achieved. This will make room for the lightbar.

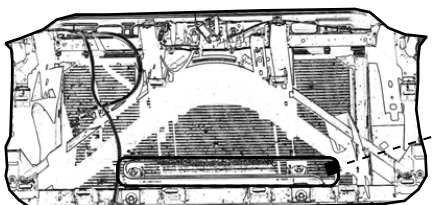

PASSENGER SIDE
DRIVER SIDE

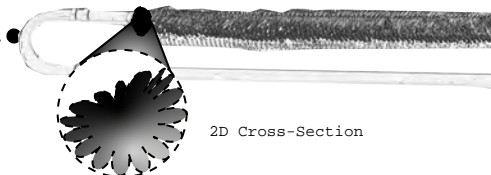

2D Cross-Section

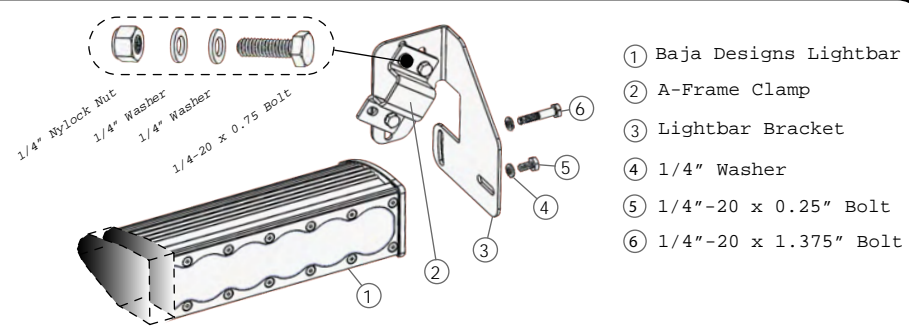

- ① Baja Designs Lightbar
- ② A-Frame Clamp
- ③ Lightbar Bracket
- ④ 1/4" Washer
- ⑤ 1/4"-20 x 0.25" Bolt
- ⑥ 1/4"-20 x 1.375" Bolt

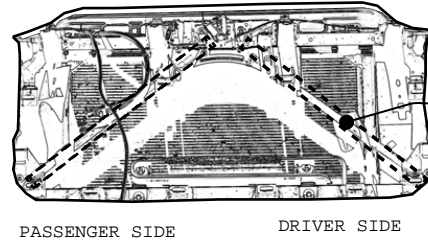

PASSENGER SIDE
DRIVER SIDE

5. Place item ③ (Lightbar Bracket) on A-frame in the area shaded.

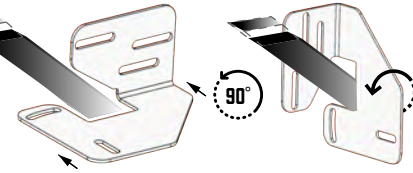

Assemble as shown above with a 7/16" ratchet and wrench. Add anti-seize to bolts for best results. The **S8** does not have item ⑥.

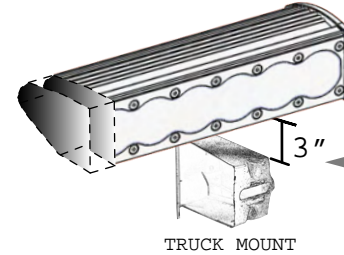

TRUCK MOUNT

The bottom of the lightbar should sit around 3" above the truck mount for the **OnX6** and sit slightly above 2 3/8" for **S8**. Refer to points ③ & ⑥ in Step 3.

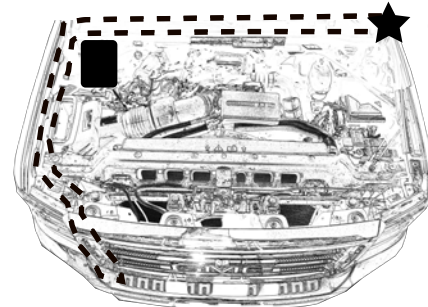

FRONT OF TRUCK

6. Route the wiring harness in the dashed region to the left. Remove the battery cover located in the shaded rectangle to the left. With a 10mm, deep socket and ratchet, undo a positive and negative terminal. Attach the proper colored leads, red (positive) & black (negative), to the terminals. Secure with the 10mm ratchet or wrench. Remove connectors from the switches on the harness.

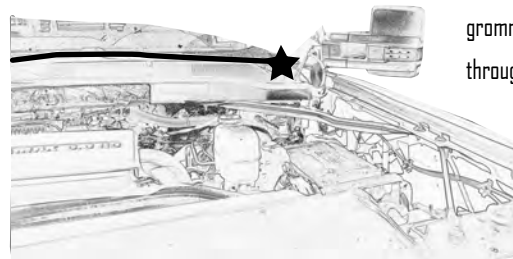

7. Route the harness to the star in the image to the bottom left. Open the Driver Side door, to reveal an opening to the engine bay where the fender and body meet, and a rubber grommet right below the top door hinge. Route wires through the engine bay opening.

Push the grommet out from the interior of the Driver Side, under the dash, and cut an "X" into it to feed wires through. Re-attach connectors to switches. **Thank you for choosing Baja Designs.**

Learn more about off-road lights we have.