



baja designs[®]
The Scientists of Lighting

2019 Ford Ranger A-pillar kit Instructions (44-7628, 44-7624)





baja designs
The Scientists of Lighting

2019 Ford Ranger A-pillar kit instructions

Tools Required

- 13mm Socket Wrench
- Standard Screwdriver (Flathead)
- 4mm Allen Wrench
- 9/16" Wrench
- 9/16" Socket Wrench

1. To begin, locate the upper hood hinge bolts circled in the picture below. These will be used to mount the A-Pillar brackets.

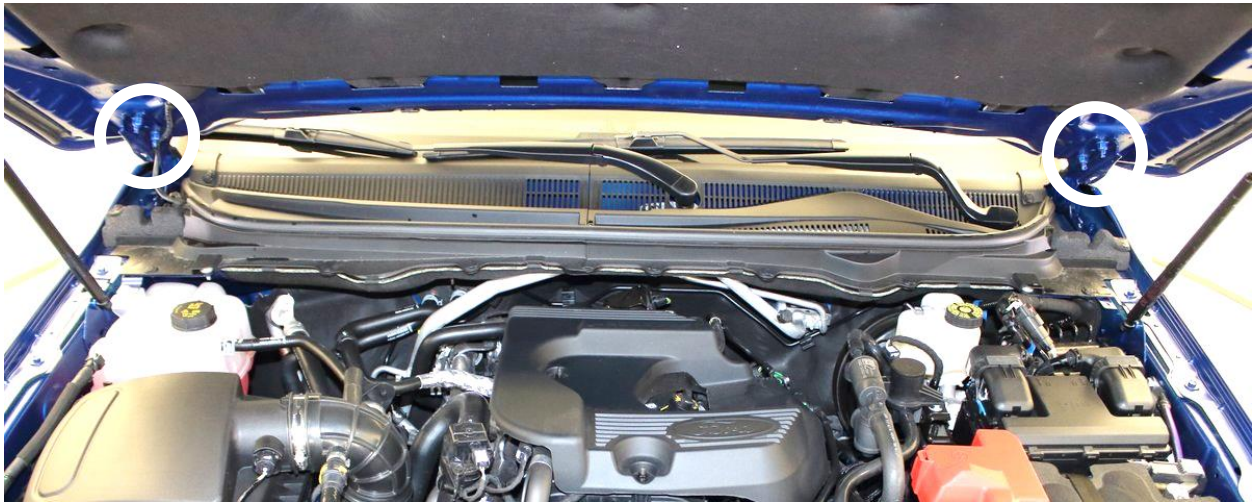

2. Place masking tape along the hood hinges (shown below) to ensure proper realignment. Also, place masking tape along the back edge of the hood near the windshield to prevent any scratches when aligning the bracket.





baja designs
The Scientists of Lighting

3. For the next steps, it is **highly recommended** to have another person closeby for assistance. Ask assistant to hold upper hood hinge against the hood to prevent any movement when the nuts are removed. With the 13mm Socket Wrench, remove the nuts.
4. Locate the driver side bracket. Place the bracket over the hood studs and hand tighten the nuts. Make sure the bracket clears the back edge of the hood and the upper hood hinge is aligned with the masking tape from step 2. Tighten the nuts snug. Repeat step 3-4 for passenger side.
5. Unbox the Squadron lights and locate the brackets and part bags. Assemble the lights to the brackets as shown in the exploded image below. Note: assemble 3/8" hardware into the bracket before mounting the light.

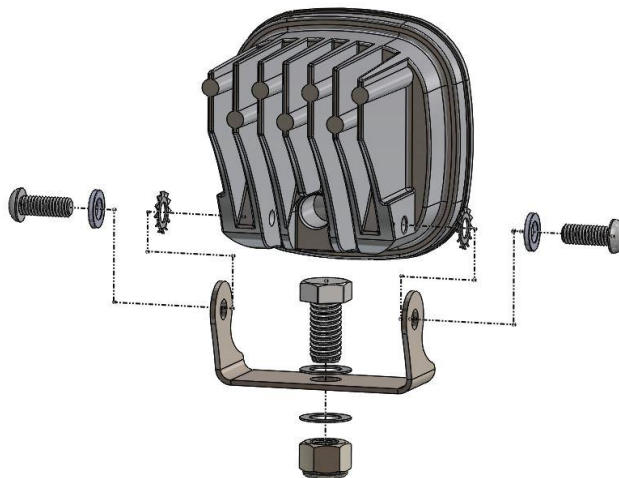

6. Close the hood. Now with the 9/16" wrench and socket, the lights can be placed onto the A-pillar brackets, aimed, and tightened.

Re-torque all the fasteners after 100 miles.

See the instructions supplied with the wiring harness to complete wiring needs.

Your install is now complete! Thank you for choosing Baja Designs.