



***baja designs***<sup>®</sup>  
*The Scientists of Lighting*

**2019 Ford Ranger Squadron Fog Pocket kit  
Instructions  
(44-7606, 44-7607, 44-7608, 44-7616, 44-7716)**



## 2019 Ford Ranger Squadron Fog Pocket Kit

### Tools Required

- T25 Torx bit driver
- 4mm Allen wrench
- 10mm, 13mm, and 18mm Socket wrenches
- Standard Screwdriver (flathead)

1. To begin, remove the crash bar bolts (arrowed on the right) with the 18mm socket wrench. Remove crash bar. Remove the fasteners circled in the front driver-side fender well picture on the right with the 10mm socket wrench. This backslash is directly behind the fog lamp area.
2. Fold back the rubber flap in between the front bumper and fender shown on the right. Carefully pull back the upper inner fender well to reveal the top of the fog light backslash.
3. With a Flathead screwdriver, pry the plastic fastener out of the backslash. Remove fastener, then remove backslash.
4. Remove the harness clip from the arrowed hole on the right. Using the 13mm socket wrench, remove the two circled bolts that mount the fog light backslash bracket. Place the bracket aside.

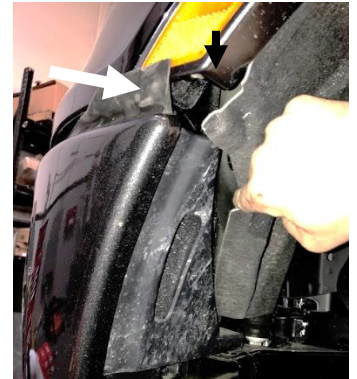

5. Unplug the OEM fog lights. Locate the four T25 head Torx bit fasteners that mount the light assemblies (Pictured on right). After removing the screws, remove the light.

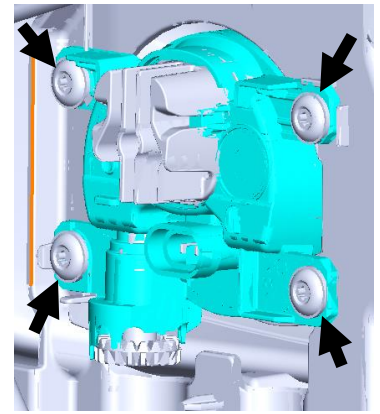

6. Using the provided hardware and 4mm Allen wrench assemble the bracket to the Squadron light in reference to the exploded view on the left below.

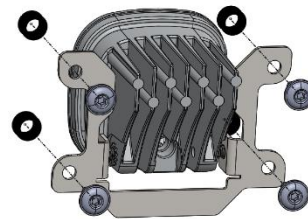
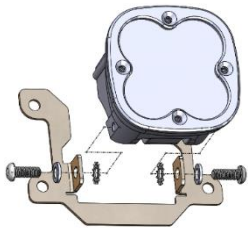

7. Mount the new fog light assembly with one OEM T25 screw and one included spacer in between the bracket and the mount (see exploded view above on the right). Thread the screw in just enough to hold the assembly in the vehicle. Place the rest of the spacers one at a time and thread in each associated screw. Tighten all four.

(Tip: glue can be used to hold spacers on the bracket while mounting.)

8. Locate the plug and play harness adapters included with your kit (pictured below). The adapter comes with the Squadron side connector unpinned, so the weather pak connector will need to be attached. Slide the black wire terminal into the side marked "A" on the connector and the brown wire into "B". Connect the inline harness adapters to the factory plugs and then plug in the Squadron power cords.

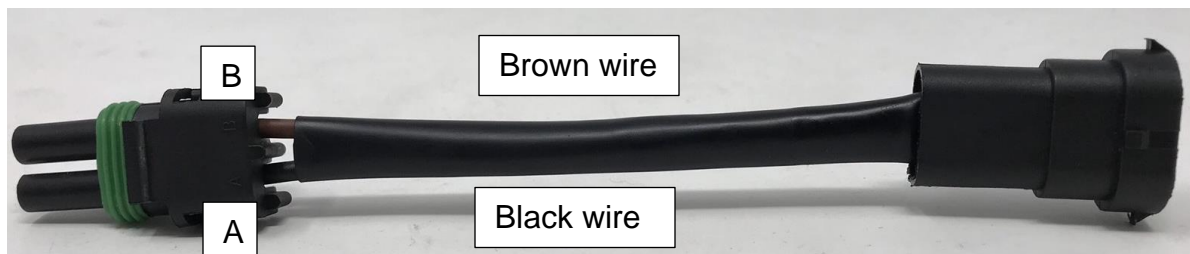

9. Now, turn on the fog lamps to aim the first light. The fog light assembly will need to come out to adjust if needed. Make necessary adjustments before proceeding.
10. Follow steps 1-4 in reverse to complete one side of the installation.
11. Repeat steps 1-10 for the opposite side of the vehicle.

Re-torque all the fasteners after 100 miles.

Your install is now complete! Thank you for choosing Baja Designs.