

Template Instructions

**ATTENTION: Read this before going any farther!
Returns will not be accepted for ANY installed PART or
ASSEMBLY. Use great care to prevent cosmetic damage
when performing wheel fit check.**

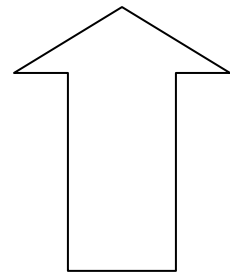
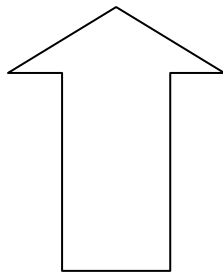
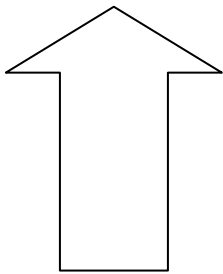

IMPORTANT! After printing a template, check that the inch scale at the bottom right corner of the page matches to a ruler or tape measure.

After you have printed a template, **PLEASE** re-check that the scale at the bottom right corner matches up to a ruler or a tape measure. Once you have verified that the template has been printed to the proper size, glue the entire page to a piece of heavy card stock and cut around the **BOLD** dotted line. Leave the hub section of the template whole until you have accurately measured the inside of the wheel hub. (**See Photo 1**)

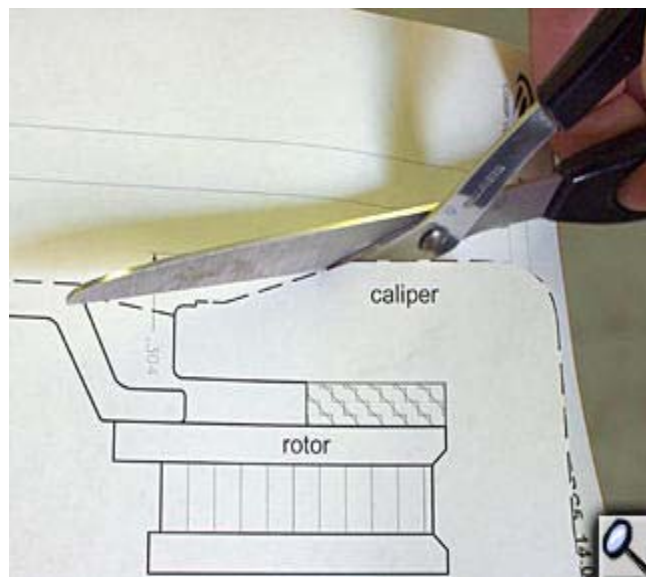

Photo 1

BAER Your Complete Performance Brake Supplier!

After you have cut the template along the bold dotted line, measure the inside diameter of the wheel where the hub goes inside the wheel. The wheel in this photo has a chamfer at the top of the hub hole. **DO NOT MEASURE THE OUTSIDE DIAMETER OF THE CHAMFER!** Measure the inside diameter of the hub hole only! This wheel measured 2 ³/₄" (from the 4" mark to the 6 ³/₄" mark) 2 ³/₄" = 2.750" After you have determined the ID of the hub hole, trim the final size of the hub area on the template using the measurement lines printed on the template. (See Photo 2).



Photo 2

It is **IMPORTANT** that to follow the measurement lines accurately on each side of the hub area on the template! (See Photo 3).

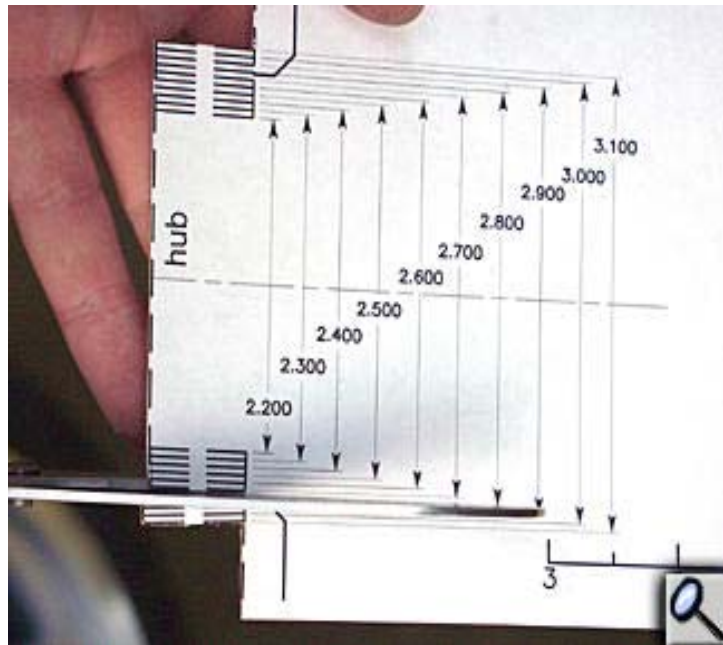

Photo 3

BAER Your Complete Performance Brake Supplier!

Once you have trimmed the hub area of the template, place the template into the back of the wheel. The hub area of the template should fit down into the hub hole in the wheel. This "Extreme" system template fits into this wheel with one exception; the template is resting on the spoke of the wheel and not allowing the template to rest flat on the hub section of the wheel. Also note that the template is very close to hitting at the top of the wheel to the top of the caliper. (See Photo 4).

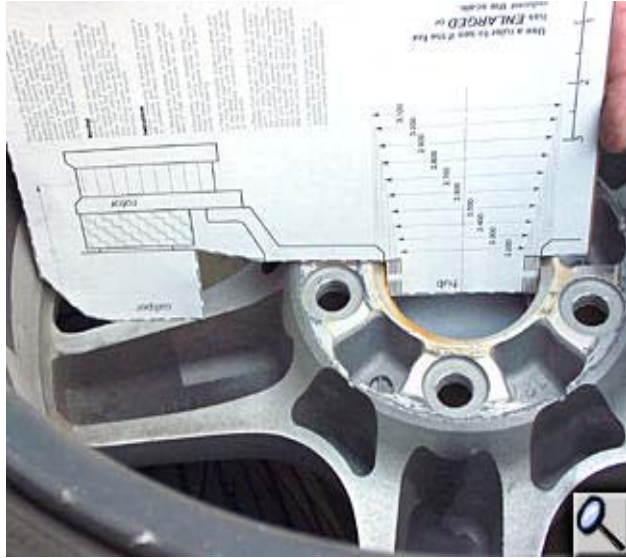

Photo 4

In this case the template is being "Spaced" out by using washers between the template and the wheel hub. The washers simulate a wheel spacer that can be used gain extra clearance from the outer side of the caliper to the wheel spokes. As the wheel is "Spaced" away from the car's hub, the rim of the wheel falls away from the top of the caliper allowing a little extra clearance. BAER recommends at least .100" clearance to any point in the wheel. This "Extreme" system template would work with this wheel if a ¼" wheel spacer is used between the hub and the wheel. (See Photo 5).

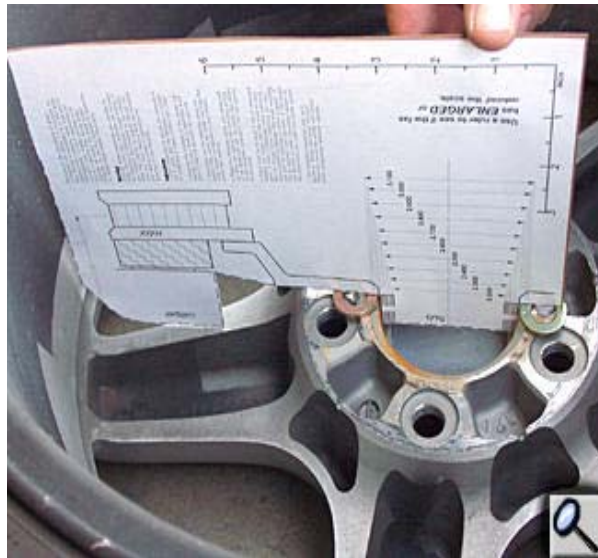

Photo 5

IF SPACERS WILL BE USED, BE SURE TO CHECK FOR PROPER WHEEL STUD LENGTH!



N117P.VLM

C10 SD6 BAER6MB, 14.0

N117P.VLM

8.049

7.221

3.003

caliper

rotor

hub

hub

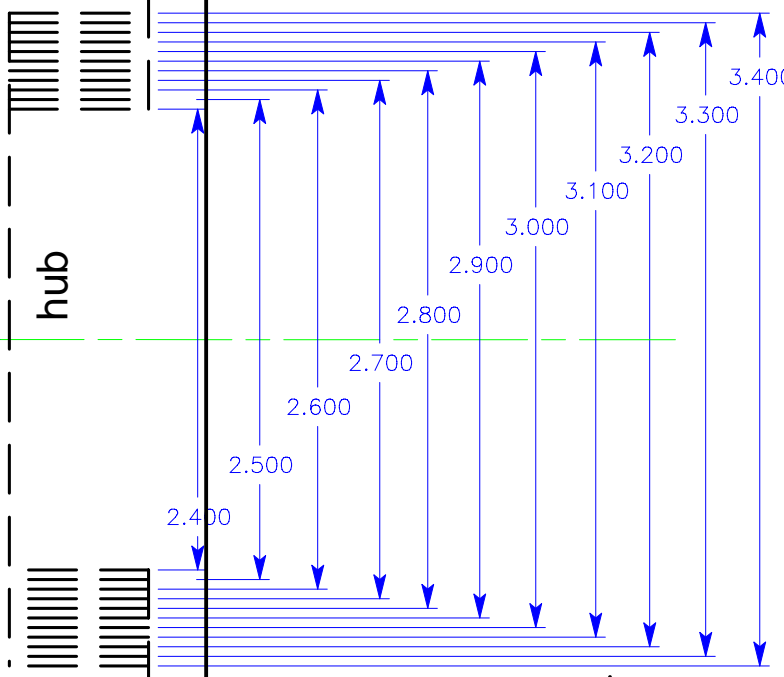

Measure hub center of the wheel, select corresponding size and cut out accordingly.

Because of the abundance of wheel companies and styles, it is impossible for Baer Racing to guarantee fit of their brake systems into a specific wheel style and/or manufacturer. To aid in determining for yourself if your wheels are likely to fit around a specific Baer Racing brake upgrade, we supply this brake system template. To use this template to determine fit, follow these simple instructions.

Warning!
Although these templates are provided to scale, fax and copy machines are notorious for reducing or enlarging images slightly. If you received this template by any method other than getting an original through the mail, you must measure both the horizontal and vertical scales to determine the accuracy of the template.

Instructions
* After measuring to ensure the template is still to scale, glue the template to a piece of cardboard or heavy construction paper.

* Measure the diameter of the center hub opening of your wheel to determine which sets of lines are accurate for your car.

* Accurately cut the template along the dashed lines, using the center hub lines that most closely correspond to your wheel's center hub opening.

* Place the template inside your wheel with cut edge flat against the mounting surface of the wheel and with the center hub section of the template centered in the hub opening of the wheel.

* There must be at least 0.100 in. clearance between the caliper and the wheel at every point. If there is adequate radial clearance, but not enough facial clearance, you may place something between the wheel mounting pad and the template to mimic a spacer. If this is required, note the width of the spacer and be sure to order the proper spacers at the same time you order your brake system.

* This template should be used as a guideline. Wheels that show minimum clearance should be verified with actual brake components whenever possible.



Use a ruler to see if the fax has **ENLARGED** or **reduced** the scale.

3 2 1 INCH