

**HEAVY DUTY REAR BUMPER  
2011-19 CHEVY SILVERADO 25-3500**

**PARTS LIST:**

1	2011-15 Chevy Silverado 2500/3500 Bumper	2	10mm Lock Washers
1	10mm 2-hole Spacer	2	10mm Hex Nuts
1	5mm 2-hole Spacer	2	6mm x 15mm Hex Bolts
1	2015+ Trailer Plug Wire Harness Bracket	4	6mm x 18mm OD x 1.6mm Flat Washers
1	2011-14 Trailer Plug Wire Harness Bracket	2	6mm Nylon Lock Nuts
1	License Plate Light	1	4mm Allen Wrench
2	License Plate Plugs	8	4mm x 10mm Button Head Bolts
2	Self-Tapping Screws (11-14 trailer plug)	4	Sensor Hole Plugs
8	14-2.0mm x 45mm Hex Bolts	4	Sealing Washers
16	14mm x 28mm OD x 2.5mm Flat Washers	4	20mm x 2mm Foam Spacers
8	14mm Nylon Lock Nuts	4	Retaining Rings
2	10-1.5mm x 50mm Hex Bolts	1	Sensor Covers Kit
4	10mm x 34mm OD x 3mm Flat Washers		

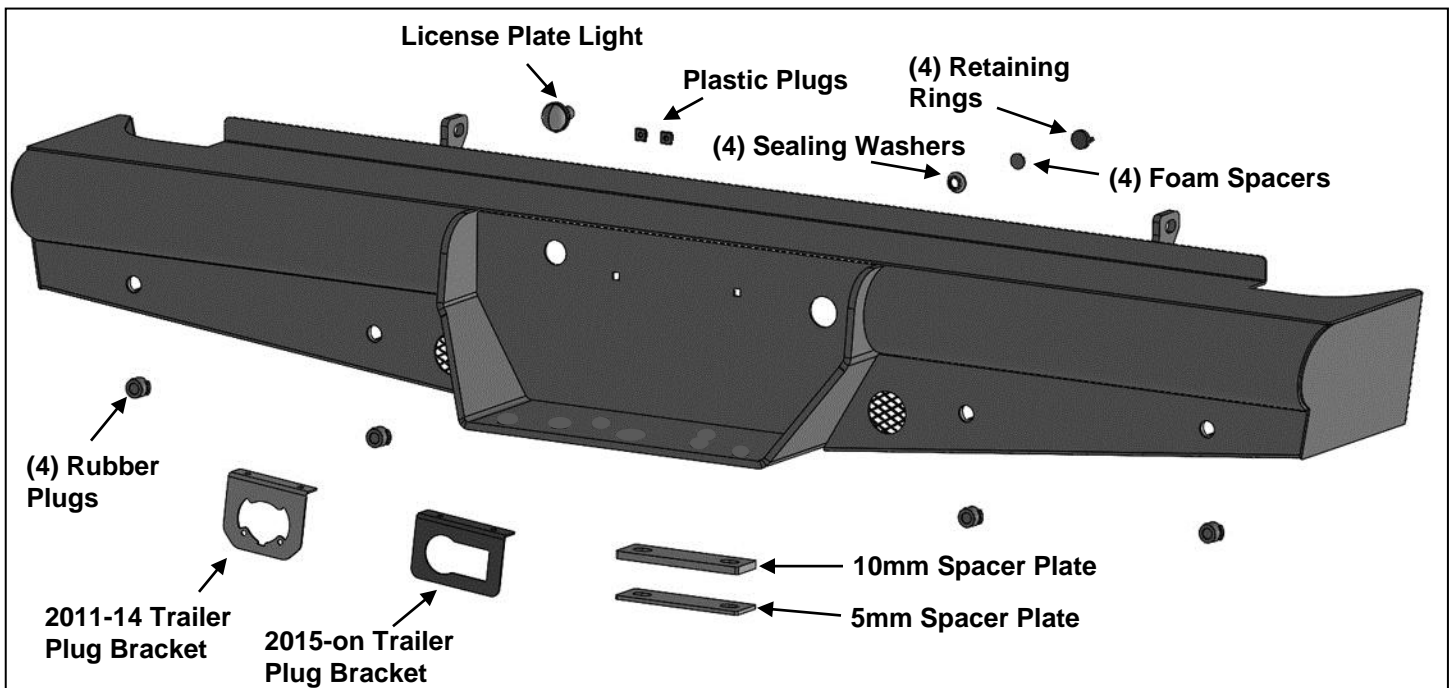

**PROCEDURE:**

**REMOVE CONTENTS FROM BOX. VERIFY ALL PARTS ARE PRESENT. READ INSTRUCTIONS CAREFULLY BEFORE STARTING INSTALLATION. BUMPER IS HEAVY, ASSISTANCE IS HIGHLY RECOMMENDED TO AVOID POSSIBLE INJURY OR DAMAGE TO THE VEHICLE.**

1. Remove the license plate. On models with bumper sensors, unplug all sensors. Remove the trailer plug from the bumper. Release the wiring harness from the clips attached to the back of the bumper and move harness away from bumper as necessary.
2. Place blocks or jack stands under the bumper to support it during mounting bolt removal. **NOTE:** Bumper may be attached to top of factory tow hitch, **(Figure 1)**. Remove these (2) hex bolts first if equipped. Once the bumper has been safely supported, remove the remaining factory bumper bolts from the side and bottom of the frame, **(Figure 2)**. **WARNING!** Assistance is required to hold the bumper in place during bolt removal to prevent the bumper from falling. Carefully slide the bumper with brackets out of the end of the frame, **(Figure 3)**. **IMPORTANT:** On some model/years, the bed will overhang the end of the frame and interfere with removing the assembled bumper with brackets. On these models, release the plastic clips attaching the plastic cover to the steel bumper. Remove cover and hardware attaching the bumper to the bumper brackets. With assistance, remove the outer steel bumper, then slide the brackets out of the ends of the frame.
3. Sensors must be installed in Bumper, (if equipped), before installing Bumper Assembly.

**Models without bumper sensors:**

**HEAVY DUTY REAR BUMPER  
2011-19 CHEVY SILVERADO 25-3500**

- a. Select the included (4) Rubber Plugs.
- b. From behind bumper, push plugs into sensor mounting holes.

**Models with bumper mounted sensors:**

- a. Remove the factory sealing washer from the sensor. Attach the provided Sealing Washer onto the front of the sensor, **(Figure 4)**.
  - b. Push the sensor in from the back of the Bumper until it is flush with the sensor sleeve. **NOTE:** Sensor tabs may need to be trimmed to fit sensor inside the sensor sleeve. Attach the adhesive side of (1) Foam Spacer to (1) Retaining Ring. Push the Retaining Ring into the sensor sleeve to secure the sensor in place, **(Figure 5)**.
  - c. Repeat the previous steps for the remaining sensors.
4. Locate the mounting slots behind the Bumper to install lights, **(Figure 6)**. **NOTE:** Lights not included. With assistance, position the Bumper Assembly up to and into the end of the frame. Temporarily support the weight of the Bumper. **WARNING:** To avoid possible injury or damage to the vehicle, do not proceed until the Bumper is fully and safely supported.
  5. Line up the forward mounting holes in the mounting plates on the Bumper with the smaller forward holes in the frame with the included (2) 10mm x 50mm Hex Bolts, (4) 10mm Flat Washers, (2) 10mm Lock Washers and (2) 10mm Hex Nuts, **(Figure 7)**. Next, attach the brackets to the larger factory holes in the frame with (2) 14mm x 45mm Hex Bolts, (4) 14mm Flat Washers and (2) 14mm Nylon Lock Nuts. **NOTE:** On some models/years, the factory tow hitch may have support straps attached to the side of the frame, **(Figure 8)**. Use the included (2) 14mm x 45mm Hex Bolts, (4) 14mm Flat Washers and (2) 14mm Nylon Lock Nuts to attach the straps to the top mounting holes.
  6. Next, from under the frame, attach the bumper brackets to the bottom of the frame with (2) 14mm x 45mm Hex Bolt, (4) 14mm Flat Washers and (2) 14mm Nylon Lock Nut, **(Figure 9)**. Do not tighten hardware at this time.
  7. Check the bumper to see if it is level and if there is a gap between the top of the factory trailer hitch and the bottom of the mounting plate on the back of the bumper. On model with bumper attached to the top of the hitch, it may be necessary to use the included 5mm or 10mm 2-hole Spacer Plate to support and level the bumper, **(Figure 10)**. Insert either spacer between the plate and the hitch as necessary. Attach the bumper to the top of the hitch, (and Spacer), with the included (2) 14mm x 45mm Hex Bolts, (4) 14mm Flat Washers and (2) 14mm Nylon Lock Nuts. Do not tighten hardware at this time.
  8. Level and adjust the bumper and fully tighten all hardware.
  9. Select the correct mounting plate for your trailer harness plug. Attach the mounting plate to the bottom of the bumper with (2) 6mm Hex Bolts, (4) 6mm Flat Washers and (2) 6mm Nylon Lock Nuts, **(Figure 11)**. **NOTE:** On 11-14 models, use the (2) Self Tapping Screws to attach the trailer plug to the Bracket.
  10. Use the included (2) push-in Plastic Nuts to attach the rear license plate to the (2) holes in the Bumper, **(Figure 12)**. Insert the License Plate Light into the hole in the bumper, **(Figure 12)**. Attach the License Plate Light wiring to the end of the factory license plate light wire harness.
  11. Do periodic inspections to the installation to make sure that all hardware is secure and tight.

**To protect your investment**, do not use any type of polish or wax that may contain abrasives that could damage the finish. Mild soap may be used to clean the Heavy Duty Rear Bumper assembly.

**HEAVY DUTY REAR BUMPER  
2011-19 CHEVY SILVERADO 25-3500**

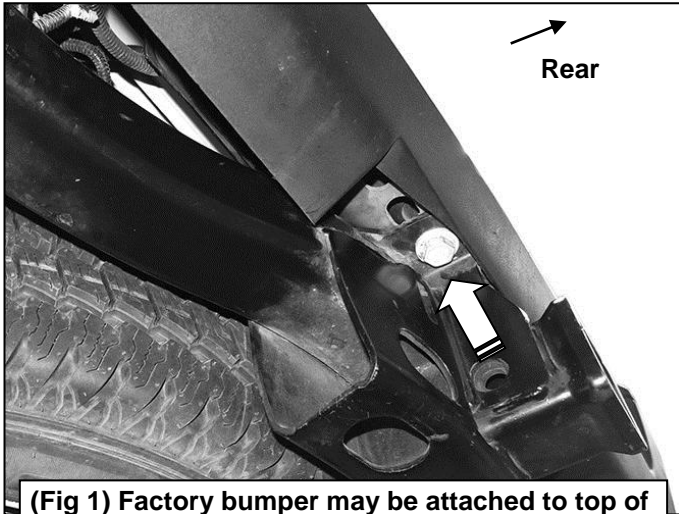

**(Fig 1) Factory bumper may be attached to top of tow hitch. Remove factory hex bolts as required.**

**WARNING! Before removing hardware, fully support the weight of the bumper with blocks or stands to prevent injury or damage to the vehicle.**



**(Fig 2) Remove bumper bolts from side and bottom of frame (arrows) as required**



**(Fig 3) End of frame once factory bumper is removed**

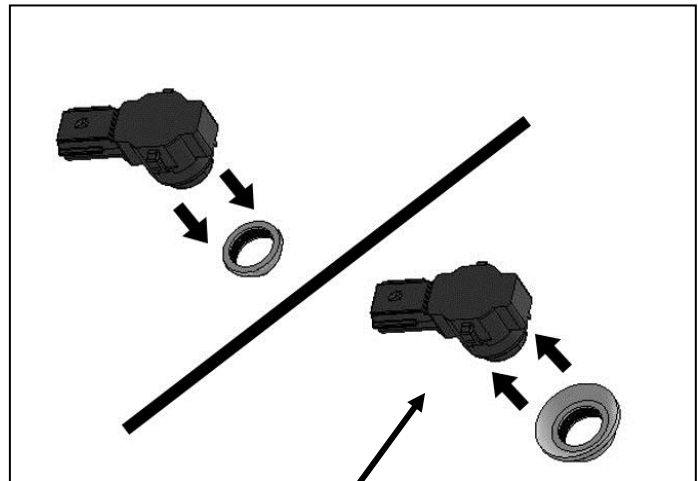

**(Fig 4) Remove silicone seal from sensor. Slide large Seal over end of sensor (arrow)**

**HEAVY DUTY REAR BUMPER  
2011-19 CHEVY SILVERADO 25-3500**

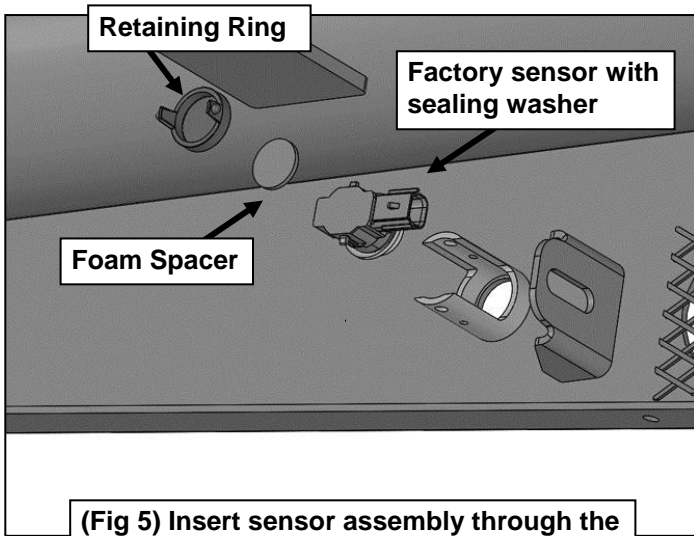

**WARNING!** To avoid possible injury or damage to vehicle, fully support the weight of the bumper with blocks or stands during installation.

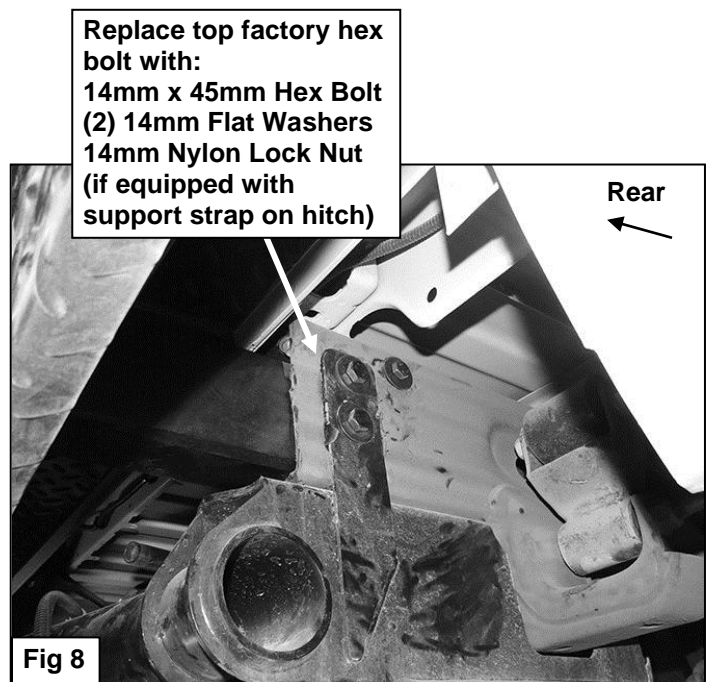
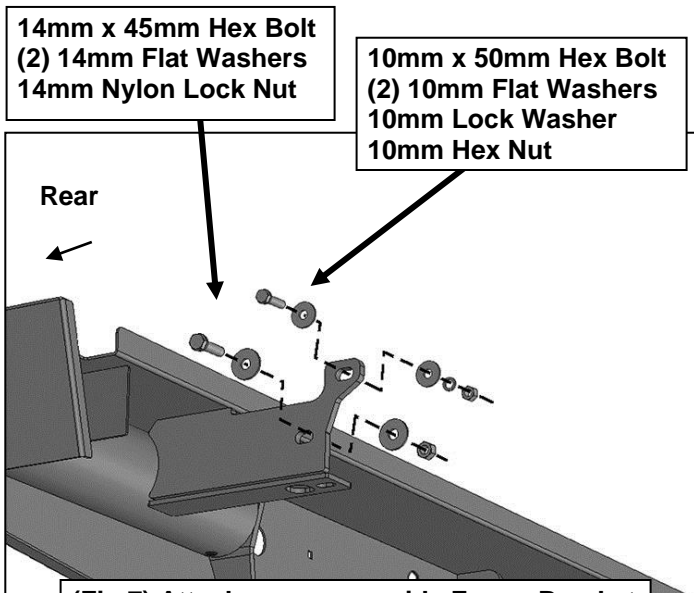
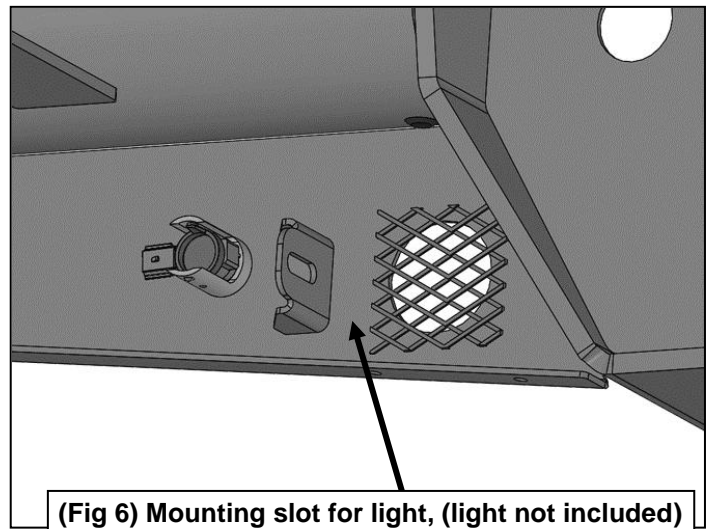

**HEAVY DUTY REAR BUMPER  
2011-19 CHEVY SILVERADO 25-3500**

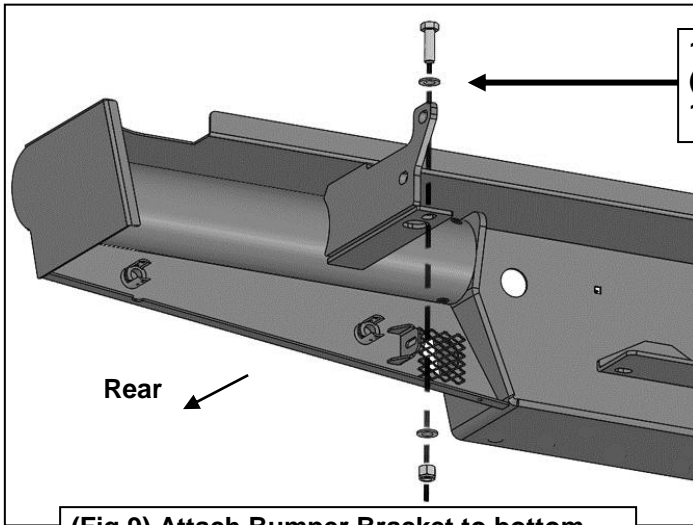

14mm x 45mm Hex Bolt  
(2) 14mm Flat Washers  
14mm Nylon Lock Nut

14mm x 45mm Hex Bolt  
(2) 14mm Flat Washers  
14mm Nylon Lock Nut

**(Fig 9) Attach Bumper Bracket to bottom mounting holes in frame. Passenger side of Bumper assembly pictured**

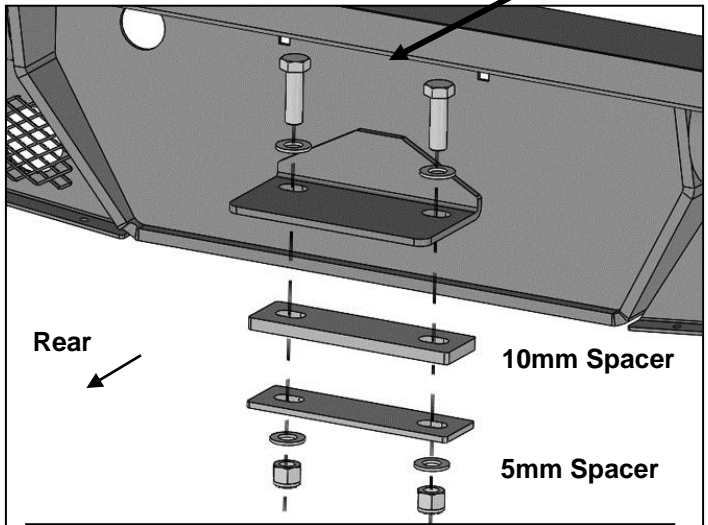

10mm Spacer  
5mm Spacer

**(Fig 10) Attach mounting tab on back of Bumper to top of hitch. Insert Spacer Plates (thin and/or thick) between tab and top of hitch to support the Bumper if necessary.**

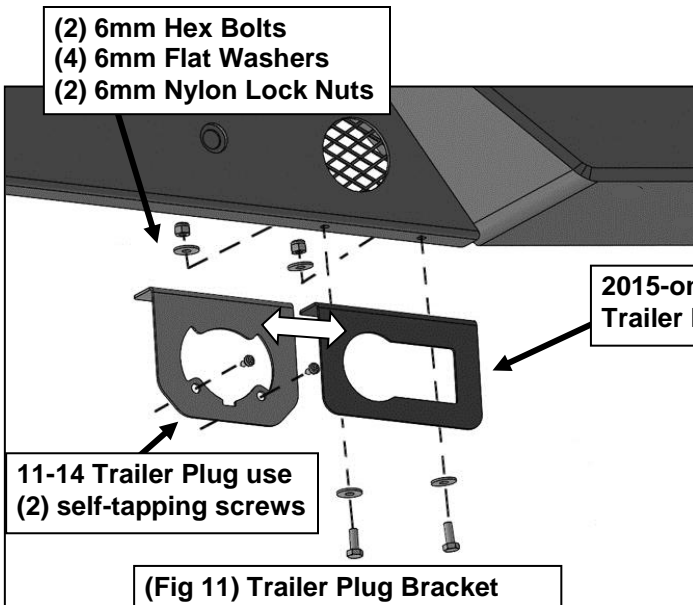

(2) 6mm Hex Bolts  
(4) 6mm Flat Washers  
(2) 6mm Nylon Lock Nuts

2015-on  
Trailer Plug

11-14 Trailer Plug use  
(2) self-tapping screws

**(Fig 11) Trailer Plug Bracket attached to bottom of Bumper**

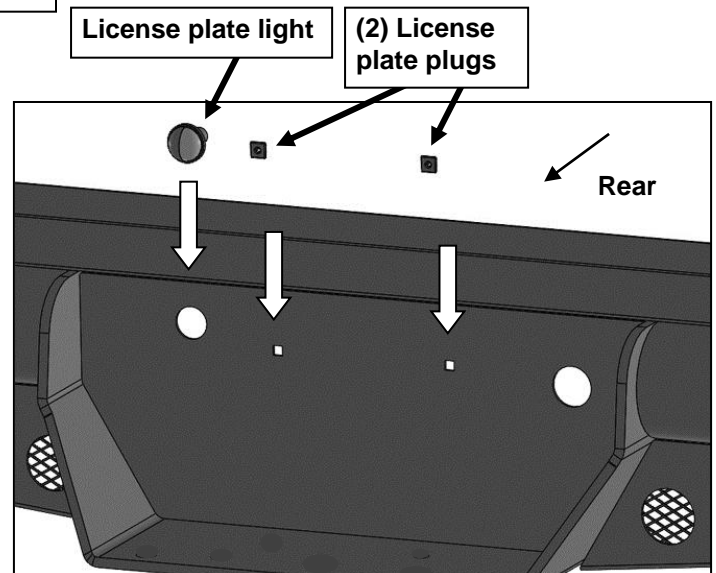

License plate light  
(2) License plate plugs

**(Fig 12) Push plastic plugs into holes for license plate. Insert license plate light into hole.**